

TEKST NR 130

1986

STUDIES IN WIND POWER

BENT SØRENSEN

TEKSTER fra

IMFUFA

ROSKILDE UNIVERSITETSCENTER
INSTITUT FOR STUDIET AF MATEMATIK OG FYSIK SAMT DERES
FUNKTIONER I UNDERVISNING, FORSKNING OG ANVENDELSER

STUDIES IN WIND POWER

by Bent Sørensen

IMFUFA Text No. 130

124 pages

ISSN 0106-6242

Abstract

The text consists of two reports commissioned by the Energy Authority of New South Wales, Australia. The first report describes the status of wind generators in Europe, with reference to export markets as well. Included in the survey are technical and economic issues, legal, regulatory and environmental aspects, as well as a discussion of the present dissemination of and operating experience with wind turbines connected to large power grids. Non grid-connected modes are briefly surveyed, with one particular case referred to the second report.

The second report is a study of wind-diesel/gas combination systems. It contains an international survey of ongoing wind-diesel projects in Europe, North America and Australia, with a short evaluation of each project. Further, the value of using models to assist planning of such combination systems is stressed, and some general requirements for the modelling exercise are discussed. Finally, an example of a complete model calculation is presented for a planned wind-diesel test facility near Sydney, aimed at extracting information from this experiment, that will be of value in evaluating similar systems placed in different wind regimes and possibly with different load patterns.

For quotation please refer to the
individual, original reports

STUDIES IN WIND POWER

Bent Sørensen

THE STATUS OF WIND GENERATORS IN EUROPE

by

Bent Sorensen*

*Visiting professor at University of NSW, School of Electrical Engineering and Computer Science. Permanent affiliation: Roskilde University Centre, Denmark.

This report was commissioned by the Energy Authority of New South Wales as part of an ongoing programme of considering energy alternatives. It has been published as a contribution towards the wider discussion and consideration of Wind Generators and their application.

The views expressed are those of the Author and not necessarily those of the Energy Authority of New South Wales.

Energy Authority of New South Wales
1 Castlereagh Street
GPO Box 485
SYDNEY 2001

Telephone (02) 234 4444

EA 86/18

ISBN 0 7305 1567 2

June 1986

CONTENTS

1.	SHORT HISTORICAL REVIEW	1
2.	PRESENT WIND TECHNOLOGY	3
2.1	Mini (1-20kw)	3
2.2	Small (20-150kw)	6
2.3	Medium (150-600kw)	7
2.4	Large (600-5000kw)	8
2.5	Status of technology	10
3.	ECONOMIC ASPECTS	12
3.1	Direct cost	12
3.2	Operation and maintenance costs.	13
3.3	Insurance	13
3.4	Site specificity	14
3.5	Financing	15
3.6	Indirect economics	15
3.7	Example of economic evaluation	16
4.	LEGAL AND REGULATORY ASPECTS	20
4.1	Safety codes	20
4.2	Stability requirements	21
4.3	Environmental legislation	22
4.4	Tariffs for grid connected generators	23
4.5	Subsidies	24
5.	ENVIRONMENTAL IMPACTS	24
5.1	Accidents	24
5.2	Health hazards	26
5.3	Work environment	26
5.4	Noise	26
5.5	Telecommunication interference	27
5.6	Ecological impacts	28
5.7	Climatic impacts	29
5.8	Visual impacts	29
6.	PRESENT DISSEMINATION OF WIND TECHNOLOGY	31
6.1	Manufacturers	31
6.2	Installed power	31
6.3	Windfarms	31
6.4	Export markets	31

7.	OPERATING EXPERIENCE	33
7.1	Reliability	33
7.2	Power output	33
7.3	Site evaluations	33
7.4	Quality of power	34
7.5	System aspects	34
8.	NON GRID-CONNECTED WIND GENERATORS	34
8.1	Wind-diesel	34
8.2	Wind-batteries	34
8.3	Wind-solar	35
8.4	Wind-biogas	35
8.5	Wind-natural gas	35
	REFERENCES	36

ILLUSTRATIONS

		PAGE
Figure 1	Arusha Windmill	3
Figure 2	DWT 18kW wind generator	4
Figure 3	Grid connected Bonus wind generator	5
Figure 4	Drive train for 75kW Vestas wind generator	6
Figure 5	300kW wind generator	7
Figure 6	MOD-2 2500kW wind generators	9
Figure 7	2301W DAF Darrieus turbine	10
Figure 8	IEA suggestions for measuring power performance	11
Figure 9	Indication of 1986 capital cost levels for different size ranges	12
Figure 10	Power curve for 95kW Micon wind generator	16
Figure 11	Economic deficit/surplus to owner during first 20 years of operating an 8 x 95kW wind park in class 2 wind conditions	18
Figure 12	National economy deficit/surplus during first 20 years of operating an 8 x 95kW windpark in class 2 wind conditions	19
Figure 13	Foreign currency payments profile for first 20 years of operating an 8 x 95kW windpark in class 2 wind conditions	20
Figure 14	Blade adjustment work	20
Figure 15	Acceptable levels for voltage harmonics	22
Figure 16	Total failure.	25
Figure 17	Summary of social surveys of noise annoyance	26
Figure 18	Wind profiles as function of distance from turbine	30
Figure 19	Ebeltoft off-shore windfarm	32
Figure 20	Possible use of fuel cells in wind (solar) - biomass stand alone energy system	35
Table 1	Establishment costs of 8 x 95kW windpark	17
Table 2	Limits on system harmonic voltages (U.K.)	21
Table 3	Californian wind power	32

SUMMARY AND CONCLUSIONS

The recent resurrection of wind technology started around 1975 and has presently reached a fairly mature stage. Modern windmills with a rated power of 50-300kW combine the advances in high performance materials, aerodynamics, mechanical and electrical engineering and control technology.

Wind technology is in many ways analogous to automobile technology: in both cases the basic principles have been well known for most of the century, but commercial success depends on high standards of quality control and industrial know-how. As in the automobile business, any new manufacturer - even one with long experience in other fields - must expect a period of several years before a mature product can be marketed. They would be wise in preparing for a learning curve where extended product improvement can take place. Early sales may be limited and economic losses may be possible, say if free replacement and upgrading of early products is to be offered in the interest of long-term credibility. This situation should be recognised by potential customers, who should select products backed either by substantial operating experience or by responsible companies. Many wind generator manufacturers have gone out of business after a few years of operating, leaving customers with practically worthless equipment.

Important considerations in choosing which wind generator to purchase are thus, maintenance requirements, service contracts and the insurance available for a given product. The best products can be expected to have operating lives of twenty years or more; that is, the period during which it pays to make necessary repairs and to continue operation. Other wind generators have become uneconomical to operate after a few years, and it is likely that several of the wind generators presently marketed will not live up to the twenty year life expectancy. This again parallels automobile technology, where established makes have operational lives ranging from eight to about twenty years, while the products of some newcomers may not even last an average of eight years.

A further consideration is the location of service capabilities relative to the wind generator sites. Maintenance and repair requirements increase with the age of a particular installation (again the automobile comparison is appropriate) and if service centres (whether independent or run by the manufacturer) are located far away, the cost of maintaining operational conditions may soon become prohibitive. The implication of this is, that if wind technology is to play a role in a certain region of the world, it must reach a degree of dissemination high enough for the establishment of local service facilities to become feasible.

The above remarks qualify the usual cost estimates made on the basis of estimated life (eg twenty years) and estimated costs of operation and maintenance (eg 2% of capital costs, per year). Provided that the two conditions of mature and local service availability can be met, wind generated electrical power or mechanical energy is presently economically viable in many locations. Obvious requirements are that the wind conditions be adequate, and that alternatives to which wind generated energy is to be compared are following typical world market prices for energy and not the particularly low prices which are available in certain well endowed regions, eg with access to low-cost hydro power or indigenous fuels with low extraction costs, which for some reason cannot be forwarded to the world market, but have to be used locally.

Operating experience with modern grid connected wind generators is of the order of 1000Mwy (or one gigawatt year), which seems adequate for drawing some conclusions regarding reliability, power quality and environmental impacts. Average outage is found to be less than 5% for Danish wind generators, while it has been near 50% for wind generators produced in the United States over the last five years [Windpower Monthly, 1985]. Again this latter figure reflects the problems of new and inexperienced manufacturers, of which most have subsequently gone out of business. A similar elimination process went on among Danish manufacturers during the late 1970's.

No problems have been encountered with respect to grid connection and power quality, and environmental problems seem to be minimal. Visual impacts have been a concern in some countries, leading to careful consideration of both the design of the wind turbines themselves and also of the smooth integration of one or more wind generators into a particular landscape. Noise and TV interference have not become major issues, because wind generators are normally sited at least 100 metres away from buildings and in rural areas, in which case both problems can be eliminated. A few poor designs have had unacceptable noise levels, but it is usually possible to reduce noise levels to acceptable values by the addition of casing or insulation. Some failures have occurred, including loss of rotor blades. One would expect the possibility of work accidents associated with outside work on top of the tower structures, but no data on this seems available.

The 1985 worldwide wind generator sales were about 700 million US\$, distributed by country of manufacture as follows [Windpower Monthly, 1985]:

United States:	48%
Denmark:	38%
Other (mainly Holland, UK, West Germany, Belgium and Italy):	14%

The 1985 distribution by country of siting was approximately as follows:

United States:	90%
Denmark:	9%
Other:	1%

Note

Although the report aims at assessing European wind technology, most examples related to installation costs, subsidies or legislation are taken from Denmark. This is in part because this information was more readily available to me, but also because Denmark is the only European country in which wind power is used on such a scale.

Currency exchange rates and prices are given at ultimo 1985 level throughout. Conversion from Danish prices is made using 6.3DKr to 1A\$.

WIND TURBINE WORLD MARKET

1985

Units sold: 14000

Turnover: One billion A\$

on average: 70000 A\$/unit

MANUFACTURE

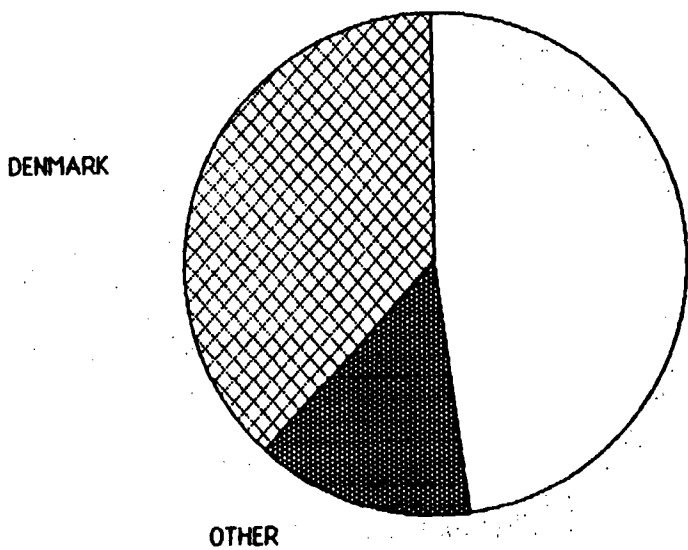

SALES

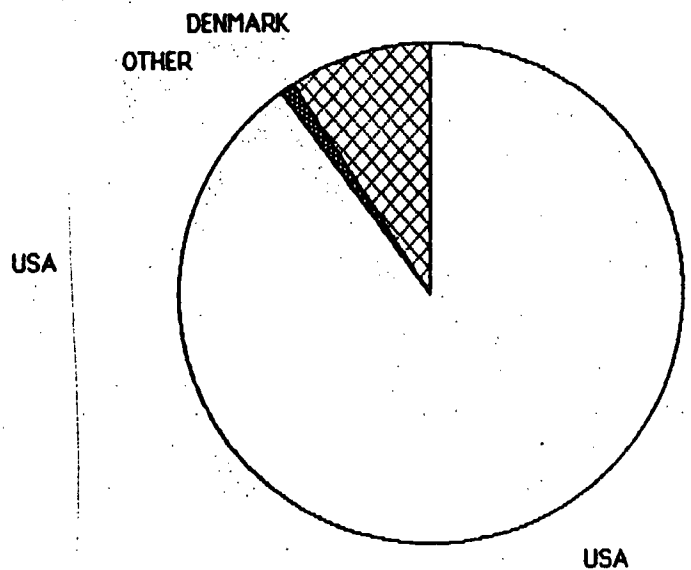

1986 CAPITAL COST OF GRIDCONNECTED WIND TURBINE

(Micon turbines for Roskilde
windpark, Denmark)

TOTAL COST: 390 A\$/ sq. m swept

POWER PRODUCTION at 6.7 m/s

av. windspeed: 750 kWh/y/sq.m

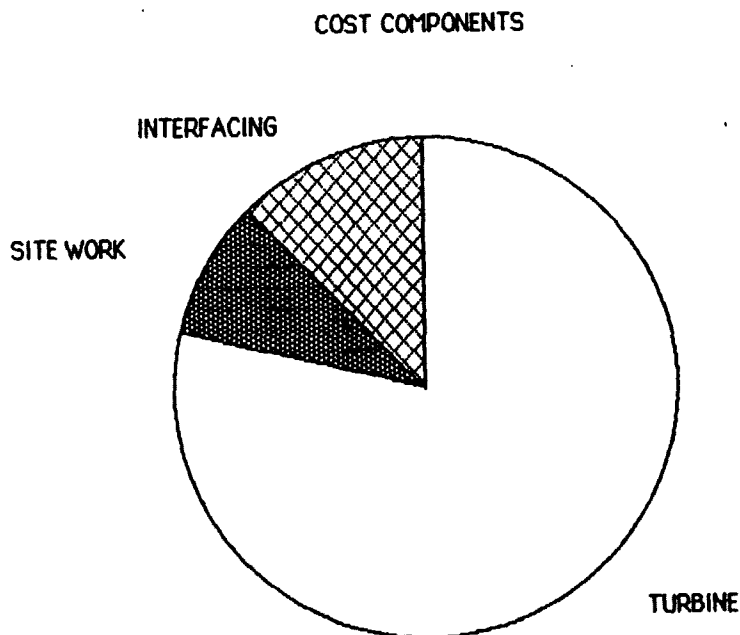

1. SHORT HISTORICAL REVIEW

During the early period of industrialisation, mechanical power from windmills and waterwheels played a fairly important role, as these were the only methods of providing mechanical power without direct conversion of muscle power (human or animal).

Also, after the introduction of fuel-based, thermodynamical machines for the provision of mechanical power, wind and hydro power continued to be used where it was practical.

As the quest for electrical power gained momentum towards the end of the 19th century, wind generators became serious contenders for electrification, particularly in rural and island communities. It was not until the 1930's, that fuel-based electricity production displaced wind-battery systems in several areas of countries such as Denmark.

A quiet break-through in wind technology took place around 1950, when J Juul (power engineer at a Danish Electric Power Company) introduced the AC/grid-connected wind generator using an asynchronous generator. The technological basis was rotors developed during WWII (for supplying power to Danish industry cut off from fuel supply during German occupation) and Juul's post-war experiments with DC grid-connected wind generators.

It took an "energy crisis" to spur world-wide interest in resurrecting wind technology. The closing of the Suez Canal provided such a crisis for European countries, and in 1957 most European countries had ambitious wind energy programs [United Nations, 1961]. Juul was funded to build a 200kW AC grid connected wind generator at Gedser. It started operating in 1959 and functioned until 1968, when the declining oil prices caused the operation and maintenance costs of the wind generator to exceed the value of the power produced. The Gedser mill was made operational again eight years later [Buch, 1977].

The 1973/74 "energy crisis" led to an immediate response from Danish manufacturers, who had commercial wind generators ready in 1975. They leaned heavily on the Gedser mill construction. A few years later a new generation of commercial wind generators appeared, now introducing advanced aerodynamics and modern materials (glass fibre, laminated wood) into the rotor construction, and making use of modern control technology. In the 1980s micro-computer control systems, optionally placed remote from the generator, have been employed by several manufacturers.

All the countries participating in the 1960 wind efforts had abandoned the projects, and the much higher power consumption in industrialised nations by 1974 caused the governmental interest in wind energy to concentrate on large units (megawatt sizes). Lead countries in this effort during the late 1970s were the United States and Sweden, followed by Holland and Denmark. Not much has come of these efforts. Most of the megawatt size wind generators were poorly designed and did not perform according to expectations.

Meanwhile, the commercial effort in wind generators of around 50kW led to substantial sales in Denmark and in the United States. In Denmark, a 30% government subsidy towards the purchase of wind generators helped to start the industry, and in the US, subsidies plus investment schemes for

windfarms (in California) led to a boom in wind utilisation starting in the early 1980s. In both countries, electric utilities buy wind produced power from the owners at fixed (and generally favourable) prices.

Many countries, particularly in Europe, have seen a number of wind generator manufacturers establish themselves solely on the basis of exports to California. Except for the Danish ones, most of these companies have no home market (cf. the market overview at the end of the summary). Since the future of the Californian market is uncertain, wind generator manufacturers are presently working intensely on opening new markets.

2. PRESENT WIND TECHNOLOGY

Current emphasis is on horizontal axis wind turbines, although cross-wind turbines such as the Darrieus rotors are being researched and could offer certain advantages, in particular for large units.

The following overview of wind technology is divided into four size ranges, each of which is characterised by the type of technology used. Borders are not sharp, and in some cases a particular machine uses technology normally associated with a different size category.

2.1 Mini (1-20kW)

Mini wind turbines of up to 20kW rated power (electrical or mechanical) aim to cover some small but essential load, often under extreme or remote site conditions. Examples are power for remote mountain posts, telecommunication links, homesteads and water pumps located far away from power grids and other energy supplies.

The areas in which these wind turbines are expected to operate are often characterised by poor wind conditions, so the technology must be adapted to these conditions. Power outputs will in such cases be low, relative to the dimensions of the machine (rotor swept area), while the cost per unit of energy will be high [Sorensen, 1983]. Even in windy areas, small machines are inherently less efficient than larger ones, partly due to lower hub height (average power in wind normally increases with height above ground), and partly for technological reasons (greater internal friction, hub losses, etc).

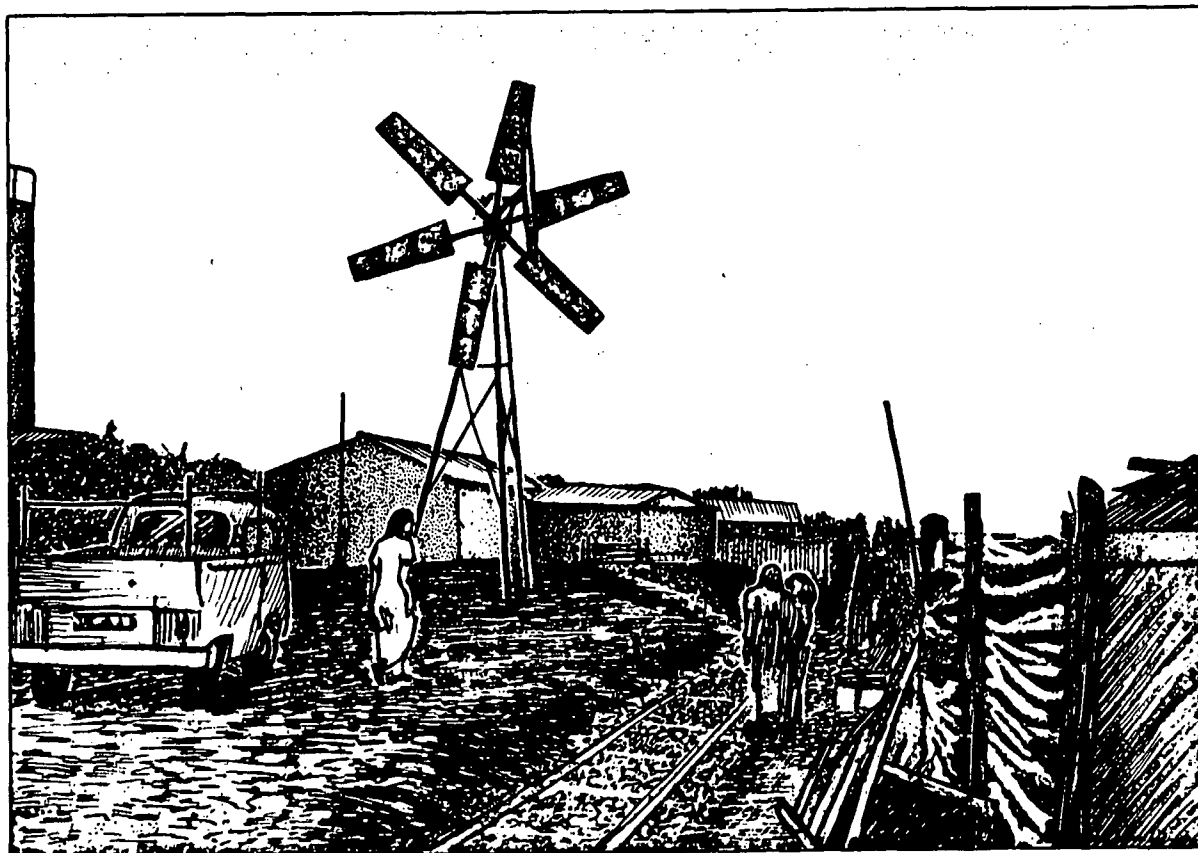

Figure. 1 Arusha Windmill (rotor diameter 5m), used for pumping water

Three approaches seem to have been followed for the construction of mini wind turbines. One is to maintain, essentially unchanged, the design of farm windmills from the early part of the 20th century. The rationale would be that since required power outputs are small, there is no need to optimise the aerodynamic design or the power transmission train. Use of materials such as sheet iron may reduce lifetime, but on the other hand would make local repairs more feasible. Although the technology is not the most cost-effective, the market aimed for consists of customers who desire some form of power at almost any cost.

The second approach is aimed at using wind energy for essential purposes, such as water pumping, in rural areas of less developed countries. Here cost is an issue, so attempts are being made to use cheap materials (for example sail cloth blades), at the expense of efficiency and durability. The technology of the multiblade farm windmills, that used to be abundantly used in Europe, U.S.A. and Australia, is employed rather than modern materials and control science, in the belief that technology for the less developed countries should be less sophisticated.

The third approach, which is not commonly followed, is to use modern technology, often taken from the larger sized wind generators, and adapt it to the mini size level. This approach has had difficulties too: scaling down tends to make the turbines more expensive than if they had been designed for their actual size, and often the translation does not sufficiently recognise the specific requirements of low wind operation. Of course, some of the mini-turbines may be operating in fairly high winds, say in applications for tele-communication links at high geographical latitudes.



Figure 2 DWT 18kW wind generator (rotor dimension 9.5m) providing power for telephone exchange unit.

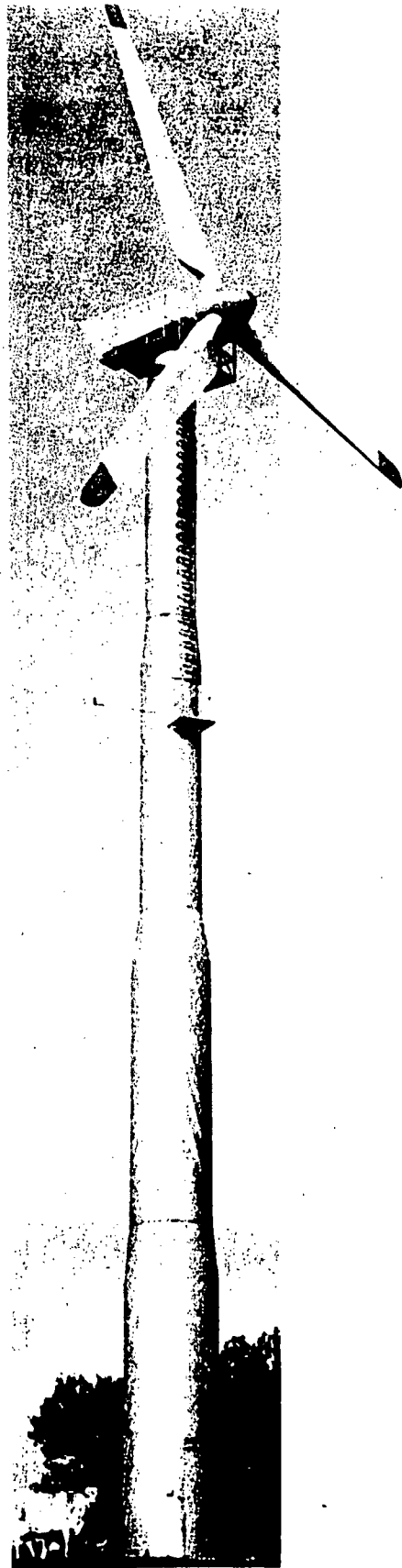

Figure 3 Grid connected Bonus wind generator rated at 95kW (plus 18kW auxilliary generator for low-wind operation). Rotor diameter 19.4m.

In short, the apparent limitations of the market seems to have precluded heavy investments in innovations of the wind technology of mini scale, and the large potential market in rural developing regions is mostly unsuited, because so many developing countries are in climatic regions characterised by very poor wind conditions. This means that other alternative energy sources, such as photovoltaic cells, are, in these regions, more appropriate and cost effective. Both insolation data and low maintenance costs favour solar technologies relative to wind, for the Equatorial regions.

2.2 Small (20-150kW)

By far the main commercial effort in wind technology has focussed upon the small size. Initially the low end of the 20-150kW rated power range was developed (1975-80), and these sizes have grown in small steps, allowing a continuity in development efforts and a low risk strategy for technology modification. Most manufacturers use reinforced fibreglass blades, but a few are offering rotor blades made of composite wood materials.

The wind generators in this range are generally supposed to be connected to a large grid, and they employ either asynchronous electric generators, in which case the grid takes care of frequency stabilisation, or synchronous generators, requiring a control mechanism for fixing the frequency of the electrical output. In both cases the grid is providing the frequency standard. Some turbines are provided with two electric generators, of which one is a small one aimed at providing some power output for wind speeds below those which are required to drive the main generator.

The smooth operation of these small size wind turbines is the result of gradual perfection of the technology over the last 15 years. Not all the manufacturers have been in operation that long, but they have generally learned from the early mistakes of others. The trouble free entrance of several new manufacturers during recent years may be taken as an indication that this size of wind generator now constitutes a proven technology.

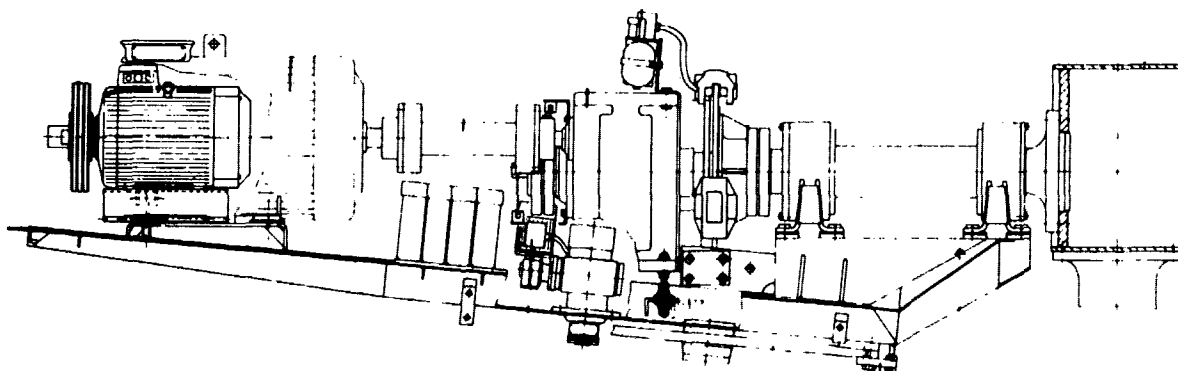

Figure 4 Drive train for 75kW Vestas wind generator.

The rotor blade angle (pitch) is most often kept fixed, which typically leads to a 5-10% lower annual power output than if pitch angle optimisation can be obtained continuously. Yawing is usually performed according to a smoothed wind vane output, with yawing speeds of the order of one revolution per minute or less.

2.3 Medium (150-600kW)

A number of prototype machines in the medium size range have been built, and a few commercial machines installed. The operational experience is still modest. Although the small sized machines may gradually be extended into the medium range, most of the existing medium size machines were designed individually and they use technology somewhat different from that of the small turbines.

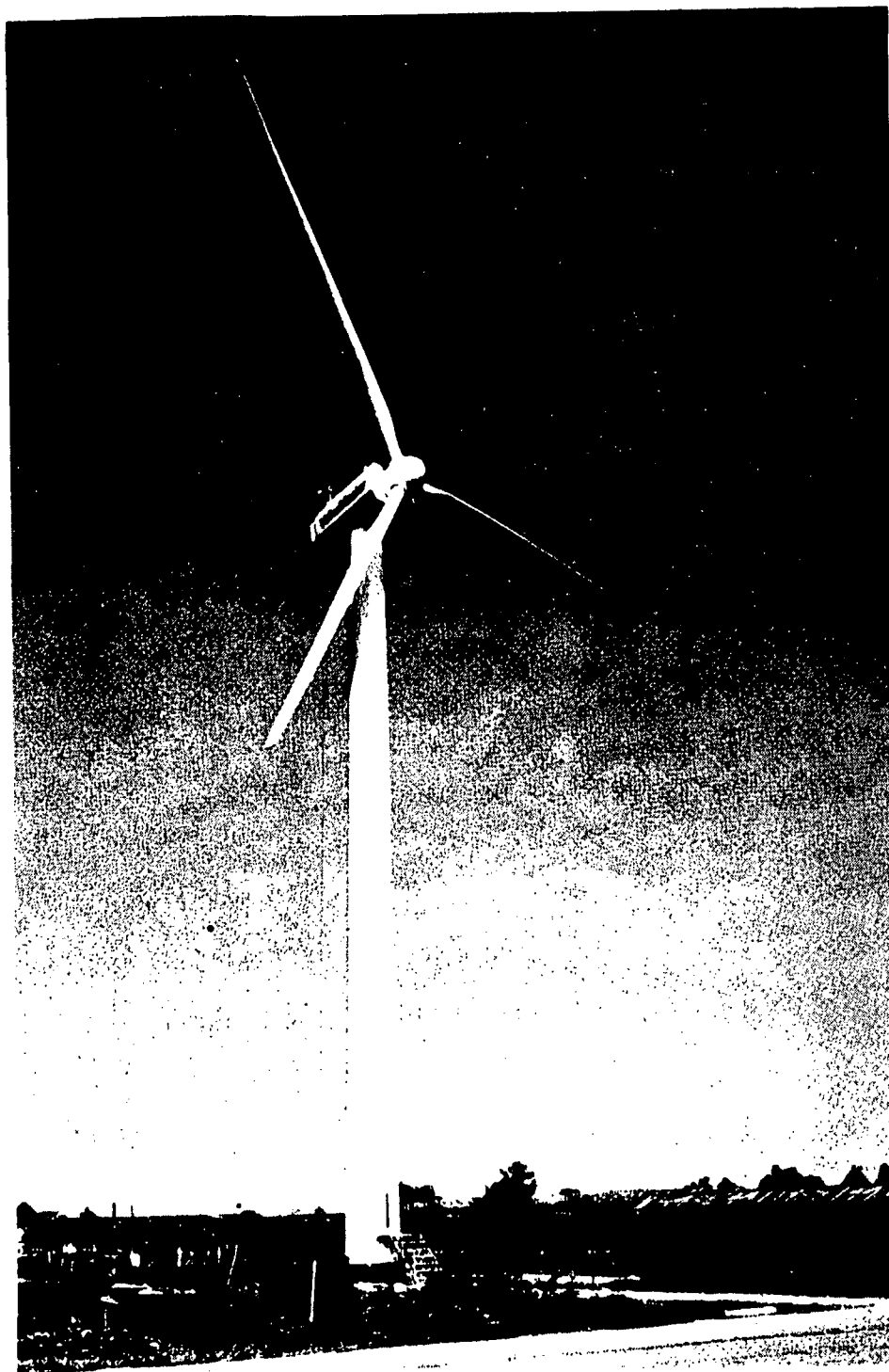

Figure 5 300kW HWP wind generator (rotor diameter 22m)

Some medium size machines were expressly meant to provide technological insight relevant to larger sized (megawatt) turbines. This implies that their safety and control equipment has deliberately been "over-dimensioned", and that materials of higher quality (and cost) than actually required have been employed.

Even when such considerations have not been made, the step from small to medium size does imply definite changes in technology, particularly as regards the rotor part. Whereas blade lengths for small machines are limited to about 10m, the medium size turbines would typically have blade lengths in the range 10-25m (rotor diameters 20-50m). This implies high bending and twisting moments, leading to more stringent fatigue specifications. Furthermore, the wind regimes experienced by the outer parts of different blades (typical blade numbers being two or three) may become increasingly different, implying net forces on the construction, which not only are higher, but which also reach high values more frequently during actual operation, than in the case of smaller wind generators.

These considerations may suggest that medium size wind turbines share several of the problems of large machines, without gaining the full advantage of increasing scale. However, it seems too soon to draw such conclusions. More experience has yet to accumulate as the medium size range has, until recently, been largely neglected.

2.4 Large (600-5000kW)

When the interest in wind energy resurfaced following the 1973/74 "oil crisis", most researchers considered the development of megawatt size wind generators as the only promising avenue. The rationale was, that, given the high electricity usage in industrialised countries, and its expected further growth, only large-scale wind turbines would be able to have an impact on energy supply. Furthermore, most countries considered the available number of adequate sites for erecting wind turbines to be severely limited, and therefore wanted to place large wind generators on such sites, if any.

It is often the case, however, that the larger machines, due to their higher altitude may find certain sites acceptable which would be unsuitable for smaller generators. Furthermore, the hoped-for economy of scale might ~~result in~~ *allow for* additional siting expenses, eg. associated with off-shore siting.

Anyway, most government wind programs have been focussing on the development of the technology for large wind turbines, with typical aims in countries such as Sweden and USA being 2-3 MW by 1975 and 4-5 MW by 1980.

The first large wind generator was built by a non-governmental organisation, the Tvind School, Denmark, in 1978. Although its electric generator is rated at 2MW, other parts have lower ratings, and the operation has been restricted to slightly over one megawatt. The machine seems to have been working satisfactorily since its initial commissioning, but detailed documentation is not available.

Most other large machines have had significantly lower performance than expected. The reasons for this have been long outage periods, requiring extensive repair work; in some cases including attempts to correct basic design flaws.

Due to the success of smaller wind generators, a number of which may replace one large machine ("windfarm" concept), most governments have stopped investing in large machines. The hopes for an "economy of scale" have not been substantiated by the practical experiments so far, and the commercial manufacturers have taken a different path, starting with smaller machines and slowly introducing new, larger models. The result of this approach may ultimately be sound commercial production of megawatt size wind generators.

This is not to say, that the "jump" into the megawatt range planned by the various government programs could not have succeeded. The technological problems encountered have been greater than expected, but not insurmountable, and the Tvind mill demonstrates that trouble free operation of appropriately constructed large wind generators is feasible.

Had a number of external conditions been different, the large turbine programmes would probably have been continued until a viable product had emerged. However, the declining prices of alternative means of electricity production, power demands lower than expected in most industrial countries and, as mentioned, the more rapid success of the windfarms consisting of smaller turbines, all collaborated in making electric utility companies and governments less interested in financing the development of large wind generators.

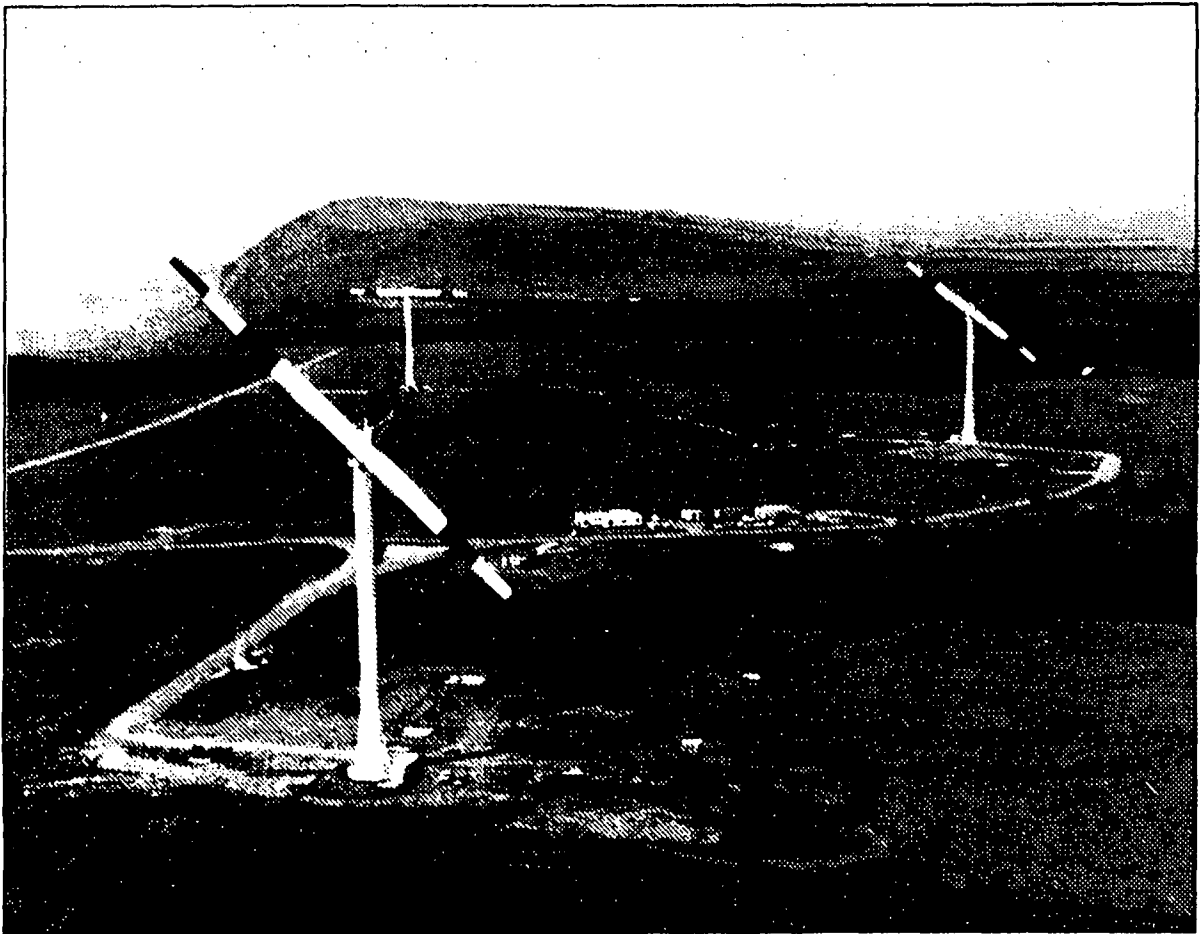

Figure 6 MOD-2 2500 kW wind generators (motor diameter 91.4 m)

2.5 Status of Technology

The basic rotor type in most commercial wind turbines is the horizontal axis, few-bladed concept. For use in extreme, low wind regimes, multibladed turbines are preferable, but on the other hand, they do not stand up to high winds. Cross-wind turbines have received some attention, and a few commercial products of the Darrieus type are available.

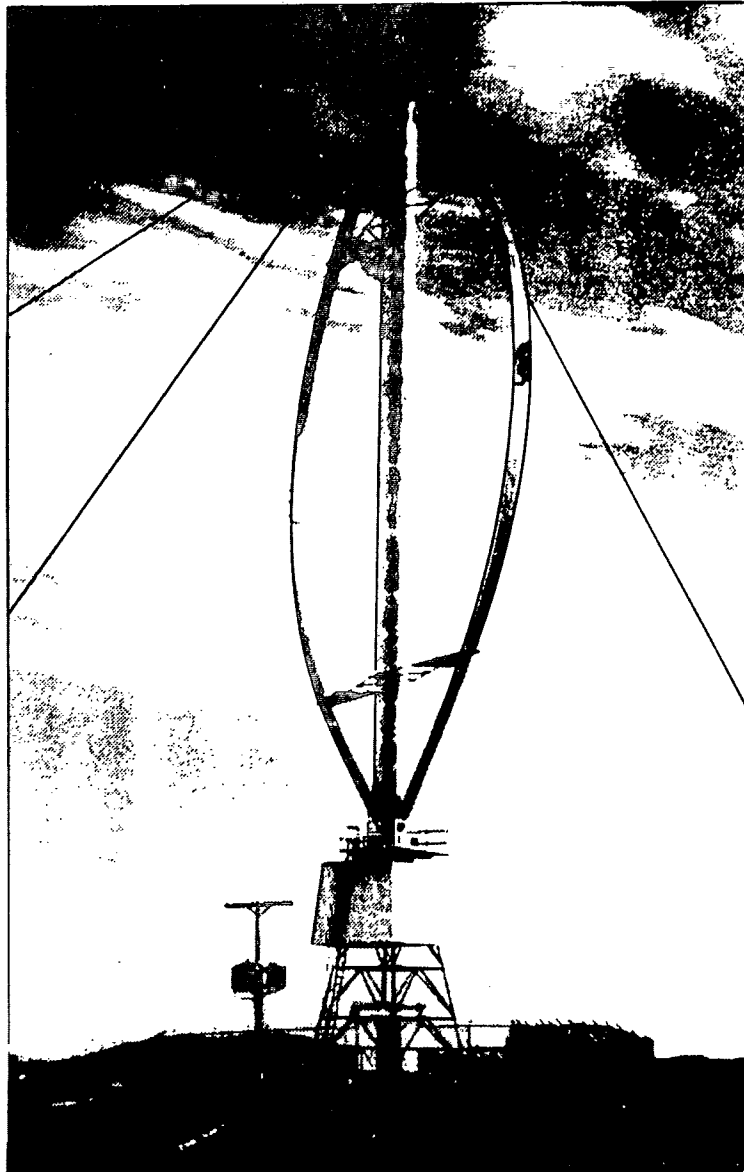

Figure 7 230 kW DAF Darrieus turbine (horizontal rotor span 24 m)

Until recently, the majority of grid-connected commercial wind turbines in the small size interval used asynchronous electric generators, but the use of synchronous generators is increasing. Their advantage is that they do not require reactive power from the grid to start and hence do not give rise to the current transients occurring when an induction generator is switched on. This advantage is relevant for larger turbines, where the higher generator cost is preferable to other means of dealing with the upstart problem.

Several makes are equipped with two generators, a main one for higher winds, and a small one which will extend operation to wind speeds 1-2 m/s lower than is possible with a large generator.

Stand-alone operation poses a number of problems, depending on the accuracy of voltage and frequency regulation required. Several schemes are being tested for specific applications (see chapter 8).

Most of the small wind generators have fixed blade pitch, whereas larger machines usually have variable pitch angle. Pitch control is a way of dealing with some of the requirements of stand-alone operation, but generally the advantage relative to the cost increase is marginal.

Different manufacturers have chosen somewhat different solutions to transmission and control problems. Often a wind vane and an anemometer is mounted on the machine, but improved control may in some cases be obtained by mounting the anemometer on a mast at a distance from the turbine. Most horizontal axis machines have the rotor placed up-wind, but downwind mounting is possible and may eliminate the need for a wind vane. The flow of the wind and hence the performance of the turbine is, nevertheless, substantially affected by the presence of the tower and nacelle. Nacelle aerodynamics and tower type are thus important considerations. Lattice towers are cheaper than tubular towers, but the considerations of safe (inside) climbing, power loss from rotor-tower interactions, and visual impacts may in many cases determine the choice.

The drive train contains propeller, brake, gear box and generator(s). Operation in connection with small and unstable grids leads to frequent use of the disc brake, and it has been found that it is very important that it be placed on the low-speed side of the gear box, in order to minimise wear on the gear box.

The International Energy Agency [1982] has established standard procedures for testing the power output of wind generators.

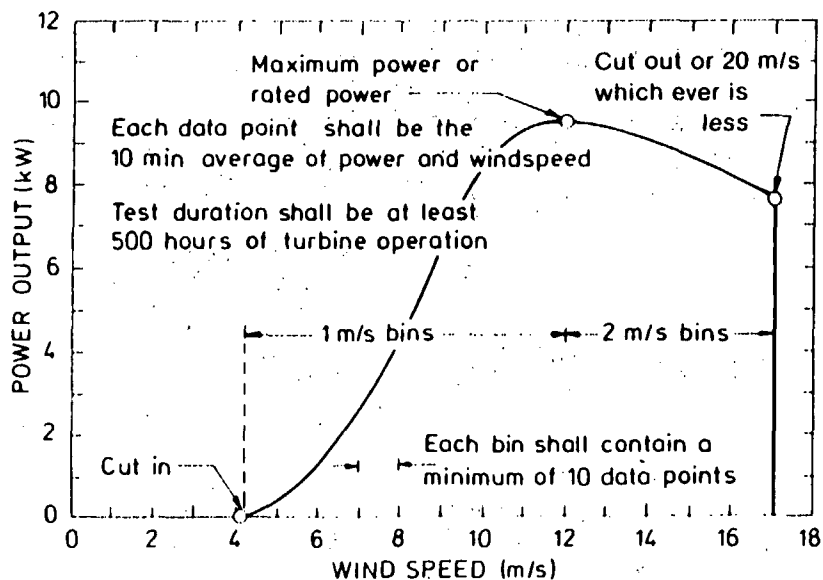

Figure 8 IEA suggestions for measuring power performance

3. ECONOMIC ASPECTS

3.1 Direct Cost

The cost of the same wind generator may vary significantly depending on its destination, shipping cost, duties, access conditions and the manufacturer's local infra-structure and interest in a given market.

Many list prices include break-in and some initial period of free service, often making the pricing policy of a given manufacturer dependent on the extent to which they already possess a local presence or a local representative.

Fig.9 indicates some gross features of the dependence of wind turbine cost on the size of machine. In many cases, rotor diameter or swept area would be the better basis for comparison, but most manufacturers tend to fix their prices so as to be competitive with other machines of the same rating (i.e. with same size electric generator).

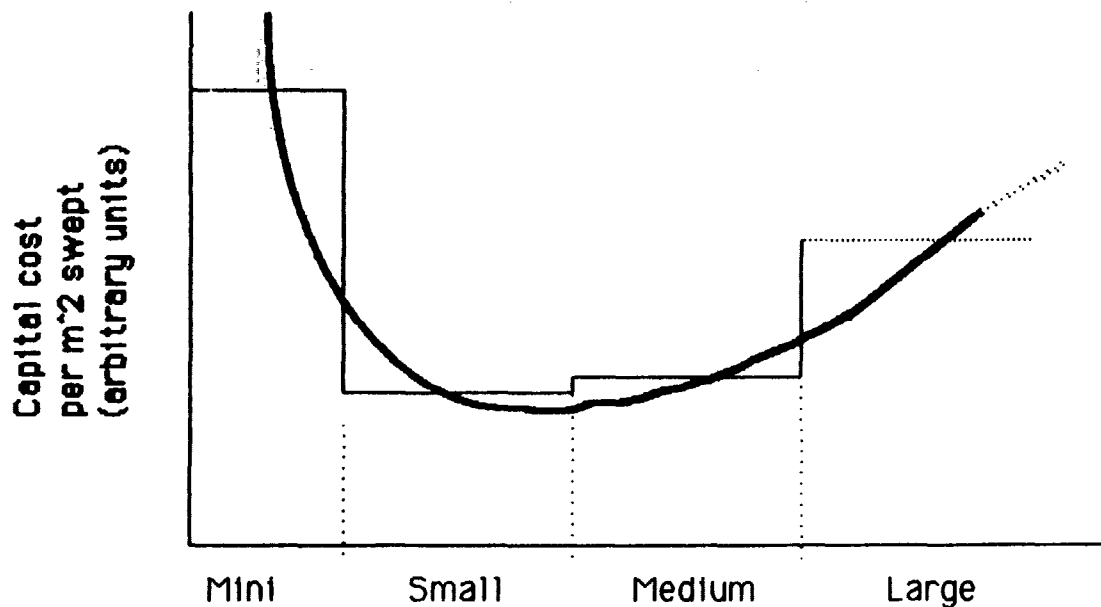

Figure 9 Indication of 1986 capital cost levels for different size ranges.

Presently, the economic optimum lies at a rotor diameter of about 20m, corresponding to a rated power of roughly 100 kW.

The total direct cost would typically comprise the following items:

- (a) Cost of Land
- (b) Site preparation
- (c) Foundation work

- (d) Wind turbine tower and control equipment, delivered on site, assembled and erected, tested and run-in.
- (e) Grid connection and possible reinforcement of grid.
- (f) Optional housing, meters, access road, lighting protection, etc.
- (g) Design and consultancy services, if any.

The wind generator manufacturer usually delivers only item d, plus drawings and templates for standard foundations. The sales contract would typically include a two year warranty and two years of free service, after which a fixed price service contract may be signed.

As of January 1986, the manufacturers price (item d) for 100 kW machines in Denmark was 6000 DKr per kW rated power (about 960 A\$/kW), with less than 10% variation between different manufacturers [Riso, 1986]. Wind generators sold in California during 1985 were priced at 1000-1800 US \$/kW (1700 - 3200 A\$/kW) [Windpower Monthly, 1985].

An example of a complete capital cost run-down is given in section 3.7.

3.2 Operation and Maintenance Costs

The operation and maintenance (O&M) costs may be divided into i) expenses for routine O & M such as fixed interval inspection and upkeep, i.e. all the expenses that would be covered by a standard service contract of the kind usually offered by manufacturers or their agents, and ii) larger repairs, including purchase of parts not covered by a service contract.

Danish experience suggests average O & M costs of 2.0% of the capital costs. [Riso, 1986], starting at a lower value and rising towards the end of the 20 year expected life. It should be noted that the estimate is extrapolated from operating experiences of only about ten years.

The first two years of O & M are, as mentioned, free according to some manufacturers' contracts, and this should then be taken into account in estimating life-cycle costs and the average power production costs based on these.

3.3 Insurance

It is in the wind generator owners' interests to insure their investments against the damage that might occur as a result of storms, short circuiting, tower collapse, blade failure, the structure being hit by vehicles, vandalism, control failures, fire, lightning or explosions.

The willingness of insurance companies to supply such coverage at reasonable cost is an indication of the reliability of the products and of manufacturers.

Danish wind generators are routinely insured according to the specifications stated above. The insurance policy covers loss of production resulting from any of the mentioned events, and also pays the value of a deficit in production, if the manufacturer's written estimate of annual power production at a given location turns out to be **incorrect**.

The wind generator is replaced with a similar one, or the corresponding new-value sum is paid, in case of total failure. Should the manufacturer go out of business before the guarantee and free service period is over, the insurance company will accept these obligations.

Insurance policies (using one particular company as the example) are binding for five years at a time (for both client and insurance company), and the cost of insurance for this period is DKr 10350 for windmills in the small size category [Hafnia, 1985] (corresponding to about A\$ 1670, or A\$334 per year). There is an owner's risk of 0.5% of the insured value, or DKr. 1500, whichever is larger. Other insurance companies charge a flat 0.9% of the capital cost items c and d (see page 12) per year [Riso, 1985].

Some Danish wind generator manufacturers pay, as part of the sales contract, 25% of the insurance premium for the first five year period.

3.4 Site Specificity

The site chosen for the wind generator enters the cost evaluation in two ways. First, the wind conditions at a specific site determine the power production as a function of time, and hence the economic value of the energy provided. Depending on demand variations and on other means of producing power, the value of one unit of energy may vary over the day, the week, and the year.

Secondly, the choice of site may influence the cost of erecting a wind generator and the cost of operation and maintenance, and as a consequence the total cost, to which the value of the energy produced is to be compared.

As stated in section 3.1, cost of delivery and erecting a wind turbine may differ by a factor of two or more, depending on whether the site is close to the manufacturer, or the parts have to be shipped to locations distant from the base of the company. Further site-specific costs include duties and taxes, the cost of local labour or of bringing along company people, and the cost of having trained personnel breaking the machine in and providing the free inspection and maintenance, if such services are included in the contract.

Similar remarks can be made for operation and maintenance costs and repair work beyond the guarantee period. These costs in particular depend on whether there are many, or just one wind generator of a particular make in the region in question. If there are many, the cost of sending out people by the manufacturer can be shared, and the establishment of a local service facility may become feasible.

To regional planners considering the introduction of wind energy, it is thus very important for the cost evaluation to decide, whether the effort will result in a few, scattered installations, or if a large enough commitment can be made to support the formation of a local service base, and perhaps also local manufacture.

3.5 Financing

Wind generators may be erected by governments or concessioned companies that have been allowed to include a component to be set aside for future investments in their tariffs. Alternatively, financing would be through loans. Here too, conditions differ depending on the type of investor in question.

A private investor would normally have available the option of a long-term annuity loan, say with twenty years running time and a fixed installment being initially dominated by interest, but towards the end by backpayment. To many private investors, this backpayment profile causes problems, because interest rates include expected inflation, so that the real value of the installment is much higher during the first years than later on. This constitutes a barrier for investments of this kind, even if they are beneficial if seen over the entire backpayment period.

This problem is compounded, if the investor has available only shorter term bank loans (i.e. a loan with a backpayment period shorter than the expected life of the wind turbine).

An alternative solution available in some countries (e.g. Denmark) is index loans, where the installments increase with time in such a way that the real value of each installment is constant. A prospective wind generator investor in Denmark is able to choose to finance his purchase by a 20 year loan either with 10% annual interest and fixed installments, or with a 2.5% index loan and installments adjusted according to inflation.

The evaluation of these two loan forms must take into account the way in which interest payments are taxed. In Denmark, all interest payments on debts are currently exempted from tax, but this is planned to be gradually changed.

Since many individual investors (farmers, etc.) would normally choose a wind generator smaller than the 100 kW machines presently constituting the economic optimum, there is an advantage of shared ownership. Most financing institutions therefore encourage people to buy shares in one or more 100 kW wind generators, rather than buying a smaller one for themselves.

Two Danish electric utility companies have taken the same attitude by establishing customer-owned companies charged with acquiring and operating wind generators. This is currently an advantage, because each co-owner can, respectively, deduct interest payments on their tax returns, while companies such as the electric utilities do not have such interest tax exemption (on the other hand, they have access to government-guaranteed loans with lower interest rates, so the best financing arrangement is a subtle balance that may change with time). The customer-owned company form is also used extensively in California, again for tax credit reasons.

3.6 Indirect Economics

Indirect economics is defined as the indirect impacts of a certain enterprise, here the investment in wind technology. Such impacts include environment, energy supply security, invulnerability to changing external conditions (e.g. world market oil prices), employment, balance of foreign payments, etc.

It is clear that these impacts depend on whether wind technology is imported or an indigenous industry is formed. The Danish wind industry has created a net labour demand of about 3000 people, which is a positive contribution to national economy during a period of less than full employment.

The effect on the 1985 balance of foreign payments caused by the wind industry has been a net foreign exchange surplus of one billion Danish Kroner (160 M A\$). The wind generators sited in Denmark will furthermore displace imported fuel during their lifetime.

Government inputs into wind R & D and subsidies (30% to Danish customers during the early years, then 20%) have amounted to Dkr. 175M, but state finances have been improved by nearly Dkr. 800M due to the wind enterprise (more tax income, less unemployment compensation) [Haeng et al., 1985].

For other countries wishing to consider involvement in wind energy, specific estimations of these factors have to be made, based on local conditions. Supply security is an issue for net energy importing countries. Environmental impacts will be dealt with in Chapter 5.

3.7 Example of Economic Evaluation

As an example of the details of grid connected wind power economy, I shall use a recent project carried out by the Riso National Laboratory [1986] for the local government in Roskilde, Denmark. The reason for choosing this example is that it is the first detailed evaluation of the new generation of 100 kW wind generators believed to constitute the present economic optimum.

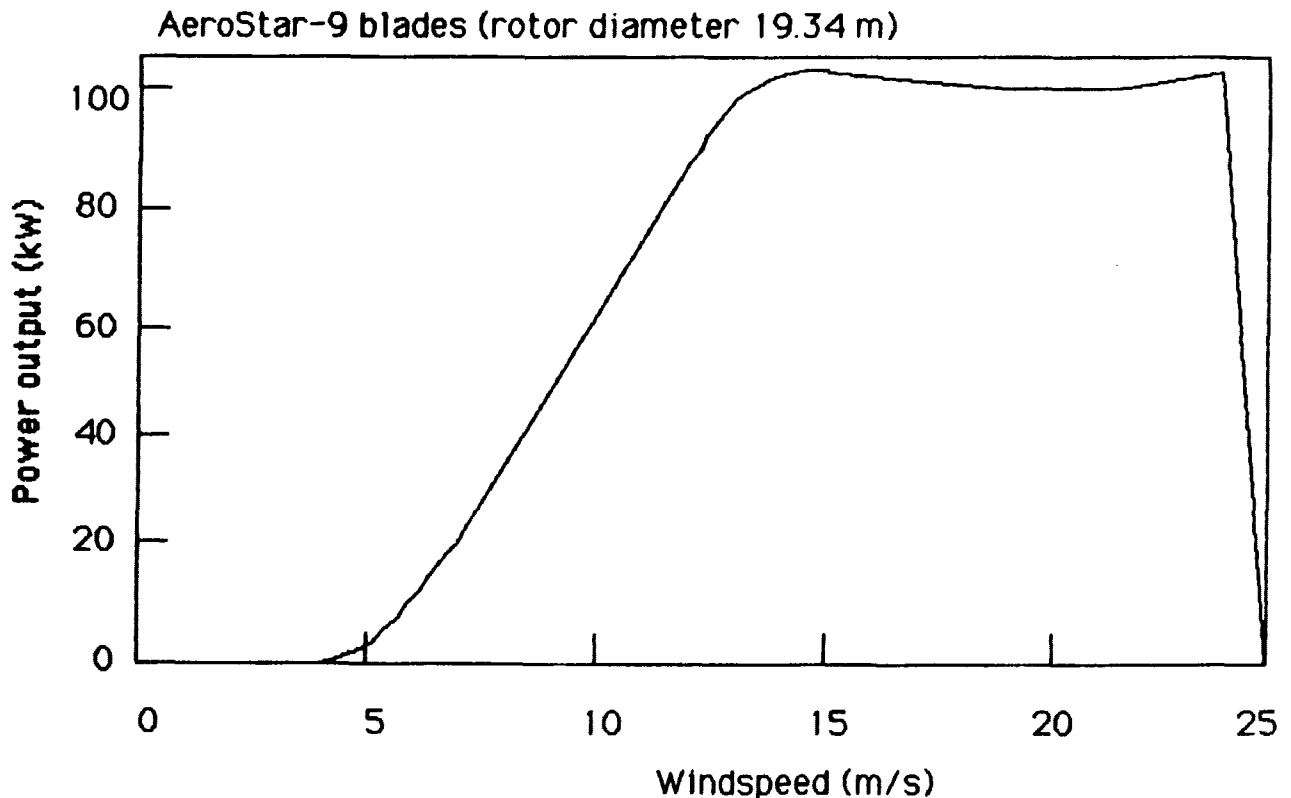

Figure 10 Power curve for 95 kW Micon wind generator

The evaluation is based on the erection of a small wind park consisting of a linear array of eight Micon wind generators (hub height 22.3m, rotor diameter 19.34m, one 95 kW electric generator, remote micro-computer control system). Two possible sites are considered, categorised as class 1 and class 2, respectively, according to the wind atlas method [Riso, 1980]. The calculated average power production per wind turbine, taking into account shadow effect, is 226.6 MWh/y for the best location (average windspeed at hub height 6.7 m/s) and 167.5 MW/h for the one in class 2. Several years of experience indicates that power production estimates based on the wind atlas method are accurate to within + 5%, for Danish locations. This accuracy could not be reached in regions with more pronounced topological variations, such as mountain areas.

The direct cost of establishing an 8 x 95 kW windpark, according to tender responses, is shown in Table 1.

Table 1

a. Cost of land (8000m ² at 5 Dkr/m ²)	40 kKr.
b. Foundations	360 kKr.
c. Turbines erected on site + 2y free service	4400 kKr.
d. Grid connection, meters	365 kKr.
e. Grid reinforcement	300 kKr.
f. Access road (250m at 300 Dkr/m)	75 kKr.
g. Optional pavilion with display of operational performance (PR)	120 kKr.
h. Engineer/architect fees	300 kKr.
Total	5960 kKr. (\$960,000 A\$)
Av. annual power output at class 2 site	1.34 GWh

A government subsidy of 20% on items b-e would be applied for. It is customary that the electric utility company to which the wind generators are to be attached offers to pay 35% of the grid reinforcement costs (item e). In the following evaluation, no government subsidy or utility contribution has been included.

The power produced by the wind turbines will be sold to the utility company at the (in Denmark) standard price of 85% of the electric power sales price for households, exclusive of energy tax and VAT. This currently amounts to 0.314 DKr/kWh (0.0506 A\$/kWh). Furthermore, producers of power based on renewable energy are refunded the government energy tax and VAT, amounting at present to 0.1891 DKr/kWh (0.0304 A\$/kWh).

The cash flow development for the windpark owner is depicted in Fig. 11, assuming O & M to cost 2% of the capital cost of turbine plus foundation, after the initial two years of free service, 0.9% before (insurance only). Financing is assumed to be 100% by a twenty year annuity loan at 10% annual interest rate (5% in real terms). Energy prices are assumed to remain constant in fixed prices.

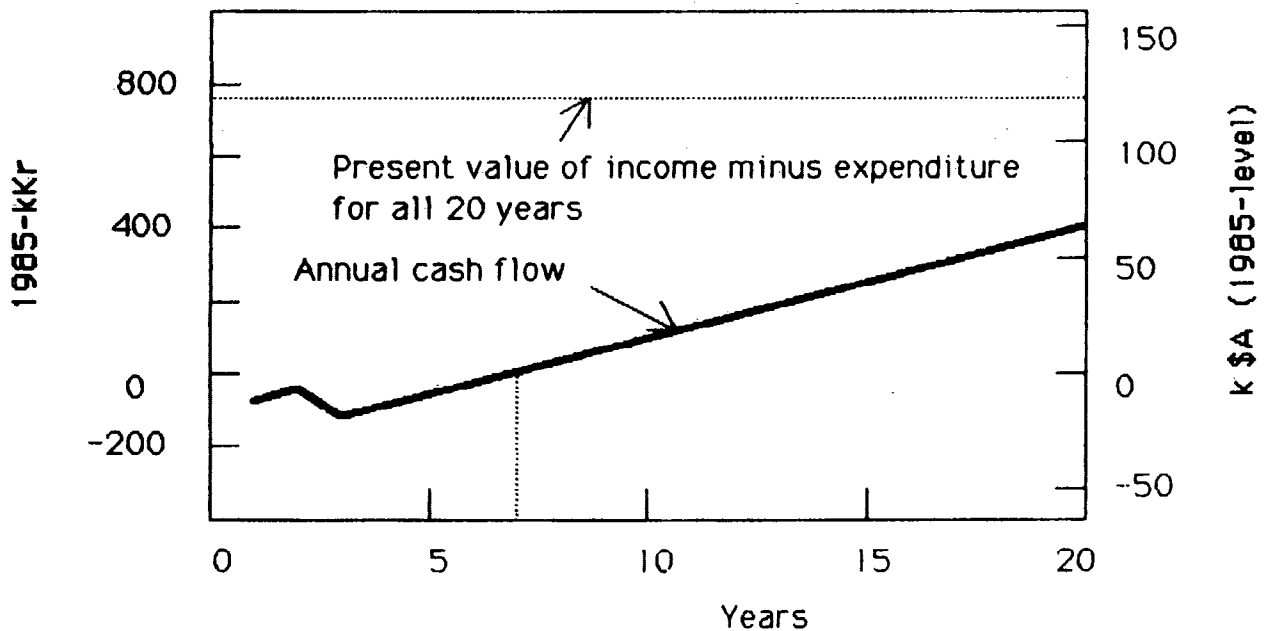

Figure 11 Economic deficit/surplus to owner (full line) during first 20 years of operating an 8 x 95 kW windpark in class 2 wind conditions. The accumulated present value of the enterprise is indicated (dashed line).

The Riso report notes that this is the first time such a calculation shows an economic advantage to the owner without considering tax exemption for interest payments, and that the reason for this accomplishment is the better cost-to-performance relations for the 95 kW turbines as compared with the previously common 55 kW installations.

Now some impacts on national economy are estimated. First the direct economy, which is evaluated relative to coal-fired power plants producing power at a cost of 0.245 DKr/kWh (0.040 A\$/kWh) using coal priced at 468 DKr/ton (75 A\$/ton) with a 2% annual increase in real terms. Assuming a 25% capacity credit for the wind installation (cf. section 7.5), and investment costs of 5670 DKr/kW for coal fired plants, 1155 DKr/kW for transmission grids, Riso finds the cash flows for the national economy indicated in Fig. 12.

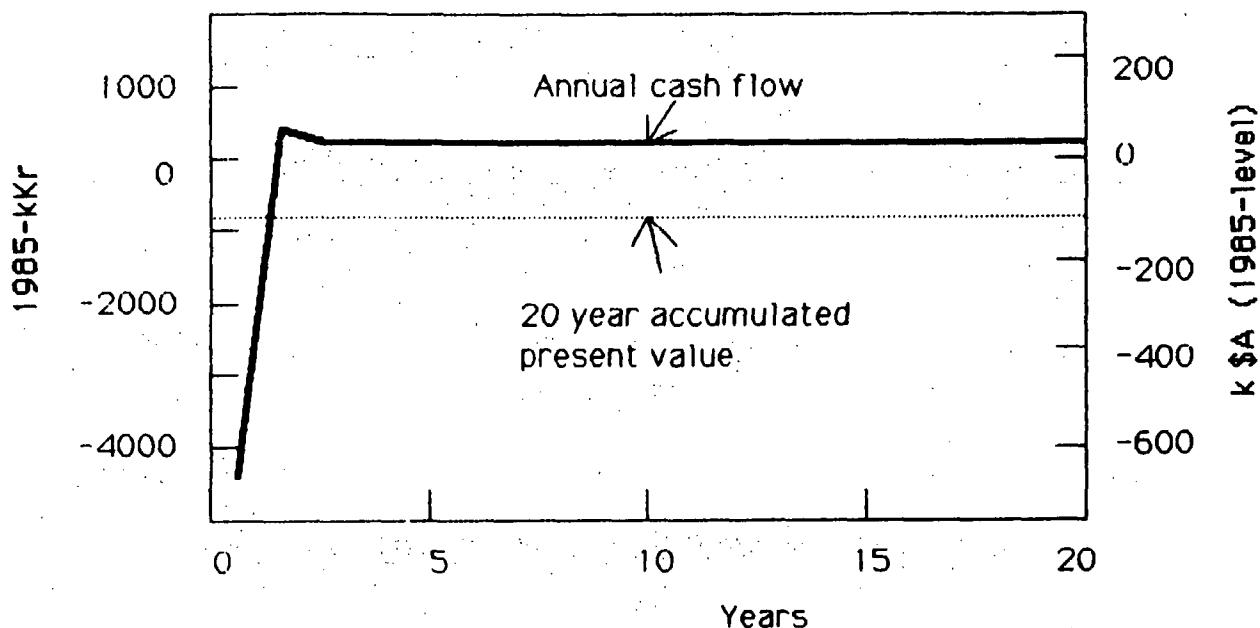

Figure 12 National economy deficit/surplus (full line) during first 20 years of operating an 8 x 95 kW windpark in class 2 wind conditions. The total present value at 5% real interest is indicated (dashed line).

While the direct economy is positive for the owner, it is seen to be negative for the national economy. It should be noted that the calculation uses a very low coal price, based on the import of South African coal, which has recently been outlawed by the Danish Parliament.

Assuming the following import fractions:

Wind generator	28%
Coal power plant	44%
O & M	15%
Coal	95%

the Riso study further calculates the foreign payment profile indicated in Fig.13.

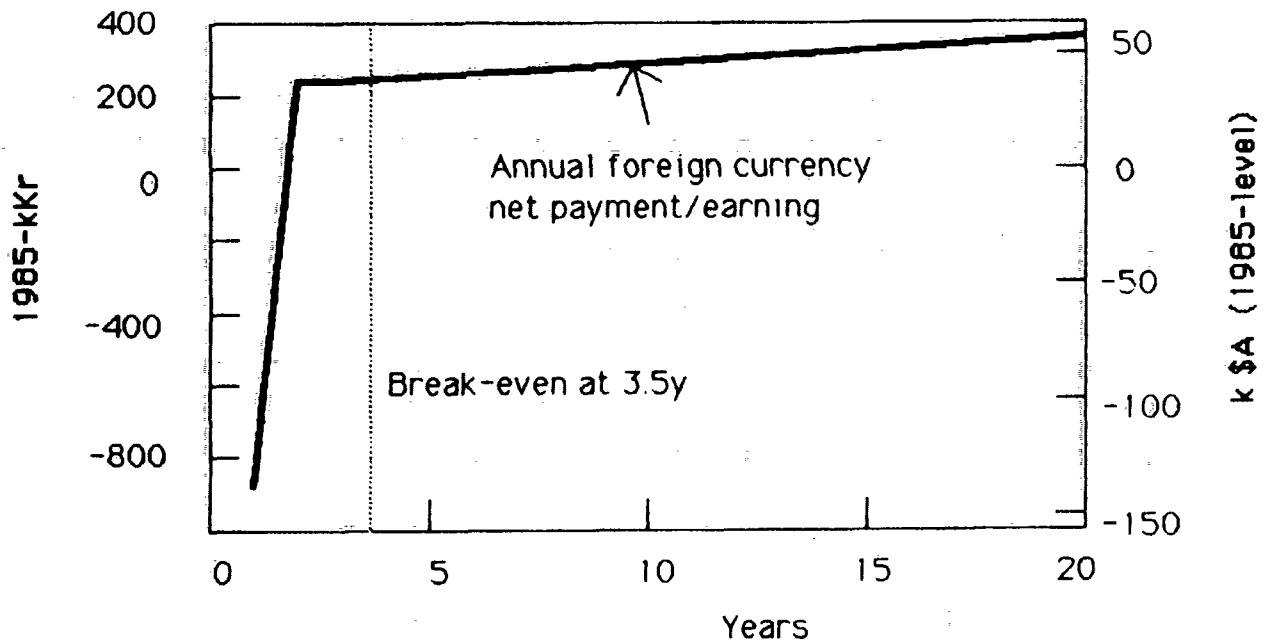

Figure 13 Foreign currency payments profile for first 20 years of operating an 8 x 95 kW windpark in class 2 wind conditions.

4. LEGAL AND REGULATORY ASPECTS

4.1 Safety Codes

Wind generators must comply with the standard building code and in some cases with industry safety codes. This pertains to all professional work conducted in connection with the machine, and obvious requirements are safety lines and helmets for climbing the tower.

The electric part of the installation must comply with power safety regulations, for example by the automatic removal of the wind generator from the grid in case of grid loses power.

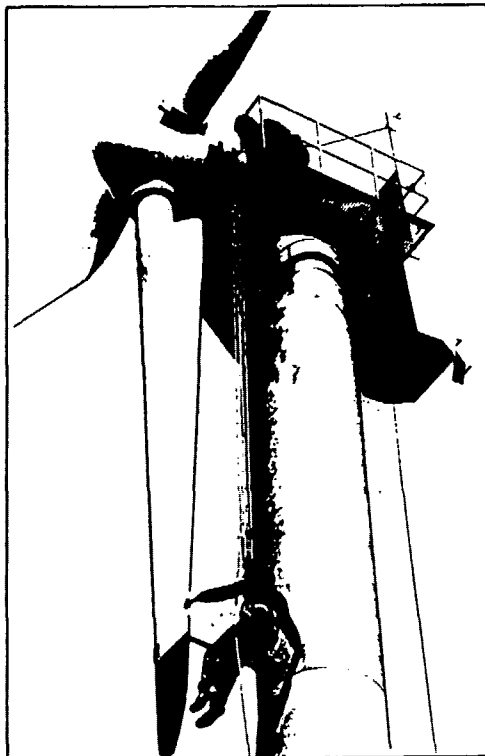

Figure 14 Blade adjustment work.

4.2 Stability Requirements

Grid connected wind generators must comply with local regulations and utility prescriptions regarding maximum acceptable voltage and frequency excursions.

Typical requirements would be a maximum of $\pm 4\%$ frequency excursions and $\pm 5\%$ voltage excursions, with automatic shut-down for voltage excursions above $\pm 20\%$ (fault protection) [Hassan and Klein, 1981]. However, some customer equipment may be sensitive to variations smaller than these. Voltage excursions due to the operation of wind generators are most likely to arise during cut-in or cut-out. Connecting an asynchronous machine to the grid usually causes a transient current several times the rated level, unless special switching equipment is incorporated. This may cause a momentary drop in line voltage. Synchronous machines do not depend on external excitation, so the terminal voltage during cut-in may be independently controlled to within prescribed tolerance.

For an asynchronous wind generator, the voltage variation may in principle be calculated in advance, from the reactive power requirement of the generator and the (perhaps!) known impedance at the point of common coupling with other consumers or equipment [International Energy Agency, 1984].

Frequency excursions are a non-issue for wind generators connected to a large grid and constituting a modest fraction relative to the controllable generators being on-line at any given moment. Typical frequency excursions for such grids are below 0.2% [Barker et al., 1983].

Harmonic voltage distortion may present a problem for some customer appliances, as indicated in Fig. 15. Several countries have guidelines or standards for maximum harmonic distortion. Australia, for instance, uses the limits also applicable in the UK, as shown in Table 2.

Table 2
Limits on System Harmonic Voltages (UK)

Supply System Voltage kV	Voltage Distortion Factor (DF), %	Individual Harmonic Voltages $V/n, \%$	
		Odd	Even
0.415	5	4	2
6.6, 11	4	3	1.75
33, 66	3	2	1
132	1.5	1	0.5

Again, given presently foreseen penetrations of grid-connected wind generators, the wave form standards do not present a problem. Little is known about the situation for local grids, such as those encountered in typical wind-diesel installations.

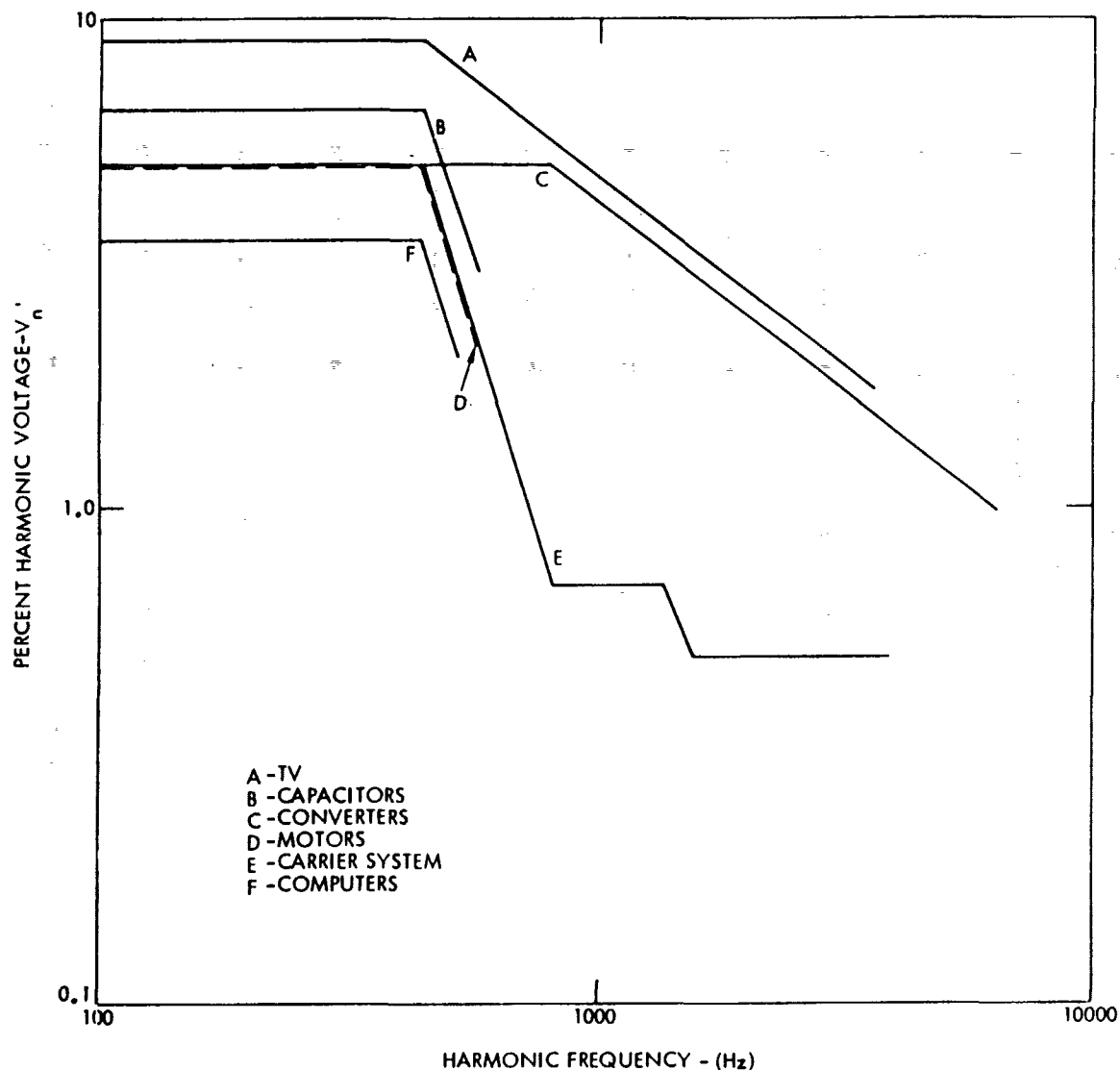

Figure 15 Acceptable levels for voltage harmonics.

4.3 Environmental Legislation

The possible environmental impacts of wind generators will be dealt with in Chapter 5. The question of compliance with legislation is relevant for each issue: work environment and safety (occupational health and safety legislation applying uniformity to all installations), noise and telecommunication interference (specific codes depending on land zoning), and the siting issues related to visual and ecological impacts (planning legislation).

Some wind turbines may be placed in or near recreational areas, where noise limits are fairly stringent (typically 35 dB with A-filter). Most commercial machines meet these requirements, as far as mechanical noise is concerned. Aerodynamically induced noise levels may be higher in strong winds, but then they are difficult to distinguish from background noise. In fact, the noise created by a tree in high winds does not comply with the 35 dB(A) limit, so aerodynamical noise from wind turbines are normally not required to, either.

Telecommunication interference is limited to a distance of about ten rotor diameters from the turbine, except in special circumstances such as turbine sites in U-shaped valleys. The solution is normally to provide cable reception from antennae placed outside the interference zone, to any building closer to the wind generator, but this solution may require approval from the relevant authorities.

The siting issue is dealt with by the planning authorities. Normally, the installation of wind generators is not allowed in urban zones or in primary conservation zones such as national parks. Exceptions can be made, eg to provide power for an isolated ranger station.

The normal location for wind generators would be in rural zones, and the general criterion for accepting them is that they blend well with the natural qualities of the landscape. The same criterion would be used for any other building or structure. They all have a visual impact, but not necessarily a negative one.

Again taking Denmark as an example, each area is required to have a "local plan", which may be just an outline as long as the area is not developed, but which has to be transformed into a detailed plan by the local government (and with participation from local inhabitants), if new use such as the formation of a windpark is proposed.

For instance the area considered for the windpark discussed in section 3.7 is covered by an outline plan, stating that:

The area is primarily to be used for agricultural purposes, but the building of a wind generator and similar equipment is to be allowed. The area is covered by conservation interests, and buildings and other structures must respect the natural values of the landscape.

4.4 Tariffs for Grid-connected Generators

Electric utility companies in the United States are by law (the Public Utilities Regulatory Planning Act, 1980 PURPA) required to accept the connection of wind generators to their grids and to buy back power generated by wind or other renewable energy systems at a fair price. Similar arrangements exist in a number of European countries, typically inaugurated voluntarily by the utility companies rather than being required by law. Some countries do not allow the connection of wind generators to the grid, e.g. France, which tries to protect heavy investments in nuclear power plants from even the smallest amount of competition.

Danish utilities require the owners of grid-connected wind generators to meter both in and outgoing power, and they buy back surplus wind power at 0.314 Dkr/kWh (0.0506 A\$/kWh), while power purchased from the utility is 0.56 Dkr/kWh, of which 0.19 Dkr/kWh is energy tax and VAT. In order to be able to buy from the utility grid, the wind generator owner must also pay the common basic subscription charge, which may be said to cover (some of) the capacity back-up provision and utility overhead expenses. There are fixed prices for initial grid connection and possible grid reinforcement, towards which the utility usually pays 35% (for the reason that the grid reinforcement may allow the utility to attach more customers than before it was present).

The buy-back price is from time to time re-negotiated between the Association of Danish Electricity Supply Undertakings and the Windmill Owners' Association.

4.5 Subsidies

Several European countries have made subsidies available for the dissemination of wind power. The Dutch government is heavily subsidising the Dutch wind turbine manufacturers, while the Danish government has subsidised the customers' purchase of renewable energy equipment. The subsidy for wind generators was 30% of the capital cost until 1984, then 20%, and currently it is contemplated to remove this subsidy as wind power seems economically viable without a subsidy. The subsidy is given only to renewable energy technology which has been tested and approved at a Government testing station. The wind turbine test facility located at Riso near Roskilde was free to the manufacturers for an initial 5 year period. It now charges commercial fees for its services.

The Danish energy tax is refunded to windmill owners based on their total production, as the purpose of the tax was to reduce energy imports.

Subsidies are also given to information activities and technical assistance in the project phase and to local citizens' groups contemplating community size, renewable energy investments.

5. ENVIRONMENTAL ISSUES

5.1 Accidents

It has not been possible to find published statistical data on accidents related to wind turbine manufacture, service and use. However, the figures related to manufacture can be derived from general industry data.

Accidents, eg falls from high places, may happen during installation and service. The risk is similar to that facing scaffold workers if external climbing and open work platforms are required. The usual safety precautions for such work apply. Wind turbines of this kind normally provide safety lines as part of the contract. Larger machines are preferably equipped with hollow tube towers for safer mounting, and the largest ones have enclosed workspaces within the nacelle.

In Denmark, one fatal accident related to wind power generation has been reported. The victim was the owner, who himself attempted to repair the electrical system without disconnecting the generator from the grid.

Most wind turbines are designed to minimise the need for climbing the tower or entering the nacelle platform, but certain repair work does involve climbing (Fig. 14), unless the tower is hinged and can be swung to a horizontal position for repair, as is the case for a few constructions.

Another, and a more wind technology specific type of accident is the one connected with mechanical failure of turbine or tower. Causes of failure which should be considered in the design and maintenance of wind generators include material fatigue, corrosion, fretting or moisture ingestion, depending upon which materials are used. Excess mechanical loads could arise from differences in wind regime experienced by different blades, particularly associated with wind turbulence and gust speeds exceeding design values, or from aeroelastic and resonance effects, tower-rotor or blade-blade interactions, gyroscopic and centrifugal loads and blocking effects during emergency stops or resulting from failure in drive train. Many of these situations could arise in the event of failing control capability leading to overspeed.

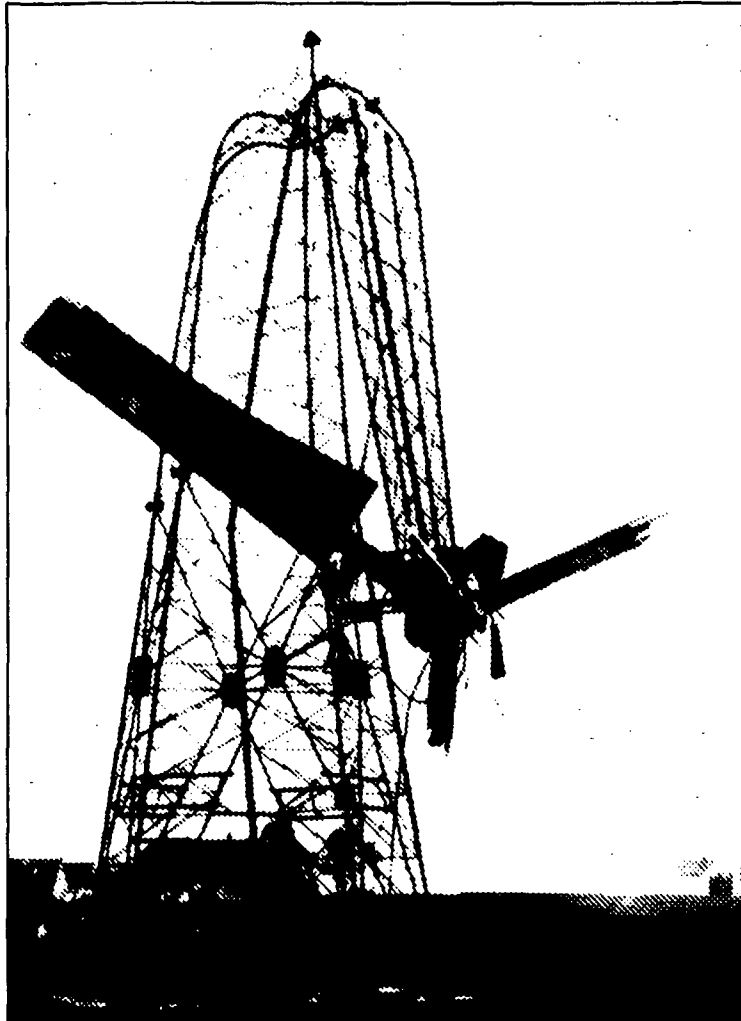

Figure 16 Total failure!

The engineering design principle which aims to deal with these accident risks is "safety throughout lifetime", obtained by built-in safety factors derived from both static and dynamic calculations of turbine/tower behaviour during normal as well as various abnormal conditions (e.g. brake failure, control unit break-down). Some accident modes are by nature difficult to calculate, e.g. impact of flying objects or abnormal lightning strikes.

The failure rate of early (1975 - 80) wind generator constructions was of the order of one to a few percent per year. Of these, only a small fraction presented a risk to people, typically by expelling parts of blades. Although the established makes have not had many such failures in recent years, it would still seem imprudent to allow the construction of wind generators in the immediate vicinity of buildings or areas likely to be frequented by people during stormy weather conditions.

This precaution is not always followed in practice, presumably because it is considered that the risk currently presented by wind generators is no higher than that of high trees, which are abundantly located near houses despite the risk of falls during storms. A numerical calculation suggests that the risk of being hit by a wind turbine blade fraction is exceedingly small more than one rotor diameter away from the tower base [Macqueen et al., 1983].

5.2 Health Hazards

Health hazards during manufacture of wind turbines include the use of toxic substances such as epoxy or glue, notably in the process of manufacturing blades made of glass fibre or laminated wood. Early production methods involved human handling of these substances, but all major manufacturers today use automated and fully enclosed machines for such processes. As a matter of fact, a few large rotor blade manufacturers supply blades to the much larger number of turbine vendors.

Few other health hazards can be identified during manufacture or operation of wind turbines, which in this respect are benign relative to other energy extraction technologies.

5.3 Work Environment

The work environment for people employed in the wind energy manufacture or service industry is generally good, offering variation of tasks and work in groups of modest size. Safety and health issues were discussed above.

5.4 Noise

Most mechanical noises from wind generators arise from the drive train and particularly the gear box. By providing sound insulation to the nacelle housing, this noise can be reduced to below any currently enforced standard (eg 35 dB(A) in certain residential and recreational areas, dB(A) being a frequency weighted scale simulating human noise perception).

Noise levels not presenting a health hazard may nevertheless be annoying to some people. There seem to be large individual variations in noise acceptance, as indicated in Fig.17. based on Keast [1978]. Depending on stage

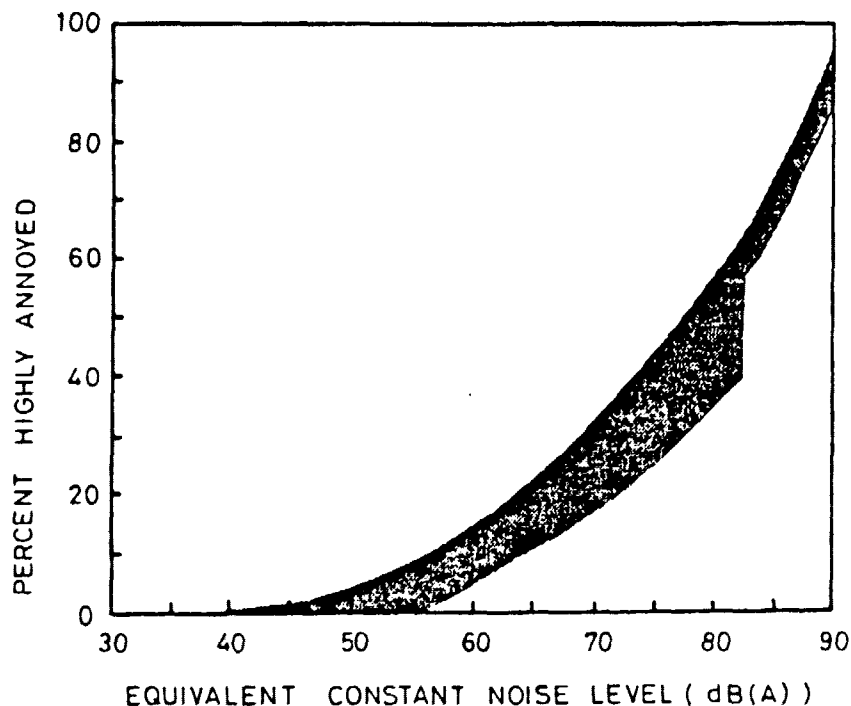

Figure 17 Summary of social surveys of noise annoyance.

of sleep, most people will wake up at noise levels of 40-90 dB(A), but some 10% wake up from light sleep at brief sound levels below 30 dB(A). Normal conversation over distances smaller than 20 m require noise levels below 40 dB(A).

The second noise component is the noise created by the interaction between the wind turbine and the wind itself. This component cannot be arbitrarily reduced, but it does depend on design features such as nacelle construction and tower type. The aerodynamical noise has a static component similar to that caused by any structure (buildings, vegetation etc.), plus a component depending on the frequency of the wind turbine rotor motion. The latter component is caused by the periodic shedding of vortices, notably when a rotor blade passes the tower structure.

For mini wind generators, the rotor frequency is often high, but for most other size categories, rotor frequencies are below 1Hz. This means that the basic frequency of the periodic noise component is below the audible range. In one case (the US MOD 1), this infrasound was significant enough to cause annoying vibrations in a building 500 m away, but other large wind generators have not had this problem, which seemed to arise from the steel lattice tower construction [Kelley et al., 1982].

The harmonics of the basic frequency noise normally have rapidly declining amplitudes.

For small and medium wind generators, the measured audible noise levels at rated wind speeds have typically been 10-20 dB(A) above background at the foot of the tower, declining to 1-10 dB(A) at a distance of 90m [Rogers et al., 1977].

Noise problems would normally be addressed by increasing the distance between wind turbine and areas occupied by people. This is generally adequate, but special conditions may occur. The sound transmission depends on the homogeneity of air, on ground reflection and on transmission through buildings, vegetation, etc. In homogeneous air, sound intensity decreases quadratically with distance, but when there is a negative upwards temperature gradient, sound is reflected as from a ceiling. Thus, sound propagates between a reflecting ground and a reflecting ceiling, causing a slower fall-off with distance as compared with the homogeneous case. These conditions normally occur during daytime, whereas the "ceiling" disappears during night-time inversions so that noise levels at a given distance are reduced.

When wind generators replace diesel operation, the noise conditions are favourably affected.

5.5 Telecommunication Interference

Wind generators may cause a distortion of telecommunication signals, either due to reflections by the structures or due to a modulation caused by the electrical properties of the moving parts.

Television interference may be discussed in terms of i) the scattering cross section or the effective area of the turbine with respect to the scattering of electromagnetic waves, and ii) the threshold modulation or maximum amplitude of the interfering signal, which will be judged as

acceptable interference between direct and scattered parts of the signal and is responsible for observed distortion of audio or video reception.

The scattering cross section is dominated by specular reflection from the broad surface of rotor blades, corresponding to effective areas of 8-25% of the rotor swept area, depending on blade material (highest for metal, low for composites such as glass fibre). The effect of adding metal strips to glass fibre blades, for lightning protection, is to increase the effective scattering cross section by about 20%, according to measurements by Sengupta and Senior [1978].

Being an amplitude modulator, interference shows up as a repetitive pulsed distortion of radio or TV signals. All other things being equal, the amplitude of modulation increases with frequency, thus, being small for FM radio signals and larger for the highest UHF TV channels. In mountain regions, complicated signal paths makes interference hard to predict.

Measurements performed 150 m from a MOD 0 wind generator give the maximum amplitude of the interfering signal as 2.6 dB (15%), in the most critical direction and for TV channel # 50 [Sengupta and Senior, 1978]. For an FM signal with signal-to-noise ratio 15 dB, the threshold for acceptable modulation is at an amplitude of 16 dB for the interfering signal. For weak signals and high frequencies, the threshold is lower.

The experience with these issues suggests, that TV interference is unlikely to be noticeable beyond ten rotor diameters from the wind turbine. Aerials may be placed outside this zone, in case TV reception inside the zone is required.

Microwave communication links and navigational systems are similarly affected, implying that wind generators should not be sited in the immediate vicinity of these installations (a concern if wind generators are powering such systems).

5.6 Ecological Impacts

Impacts of materials extraction are not specific to wind generators and will not be discussed here.

A hazard to birds and airborne insects may exist, partly due to the static structure and partly due to the moving rotor of wind turbine.

Some windy sites near sea or lakeshore are also of vital importance for migrating bird species, which are known to sometimes collide with towers, buildings, transmission lines and poles. Strong lights are known to distract certain birds from taking evasive action.

Migrating songbirds normally fly at an altitude of 150-450 m, while water fowl and shore birds occupy higher altitudes. For small and medium wind turbines, impact probabilities are thus associated with a "tail distribution" of exceptionally low flight altitudes.

Several field studies have observed birds taking evasive action when approaching a turning wind turbine, in order to avoid collision. The speed of blades is normally slow enough for the birds to be able to change a collision course, in contrast to the situation for obstacles such as planes.

In fact, no studies to my knowledge have found birds killed by an operating wind turbine. One case has been reported of a possible bird kill by a non-operating wind generator. During the period monitored, about 100 bird kills against a nearby massive building (a nuclear power station) were observed [Rogers et al., 1977]. The open structure of the wind turbine rotor gives better opportunity for evasive action. The average bird immigration rate in the study of Rogers et al. was 3.4 per hour and per metre of ground projection perpendicular to the direction of flight.

Insect release experiments at wind turbine sites have shown no discernable effect.

5.7 Climatic Impacts

Investigations of possible changes in micro-climatic parameters as the result of operating wind generators have been made, including such parameters as windspeed, precipitations, evapotranspiration, temperature and concentrations of minor atmospheric constituents [Rogers et al., 1977].

The most obvious impact is the slowing down of the slipstream wind. At its optimum, the energy extraction of a wind generator corresponds to a reduction in windspeed by a factor of 3, immediately behind the rotor [Sorensen, 1979]. Typical modifications of the wind-height profile as a function of the downwind distance are shown in Fig. 18, based on wind tunnel measurements [Alfredson et al., 1980]. It is seen that the wind speed modification is initially confined to rotor height, but that ground level disturbances appear 4-8 rotor diameters downstream. It is these disturbances which may cause microclimatic changes, because such changes are most sensitive to the conditions within a very narrow boundary layer near the ground. However, the changes in profile near the ground are modest, and no microclimatic effects related to this boundary layer have been observed.

As for wind speed reductions, the ten diameter recovery distance indicated by the wind tunnel experiments exceeds the one expected and found in the field. The reason is the higher variability, also as regards direction, of the natural wind, which makes the wake effects of a single wind generator undetectable 2-3 rotor diameters away (4-5 diameters away for very large turbines [Zambrano and Gyatt, 1983].) For wind farms, an accumulated effect has been observed.

Rainfall deficits (max. 5%) are restricted to 0.75 rotor diameters from tower and occur only when the turbine is at a standstill [Roger et al., 1977]. In summary, the continued use of land for agricultural purposes will not be impeded by the presence of wind generators.

Macroclimatic impacts are unlikely, even for ambitious plans for the worldwide utilisation of wind energy. Present total world energy use is more than two orders of magnitude below the scale of 10^{15} watts, which characterises the solar energy transfer into the global wind system, to make up for frictional losses [Sorensen, 1979].

5.8 Visual Effects

Wind energy systems may produce visual impacts deriving from the generators themselves, from transmission lines to the site and from support facilities such as central housing etc.

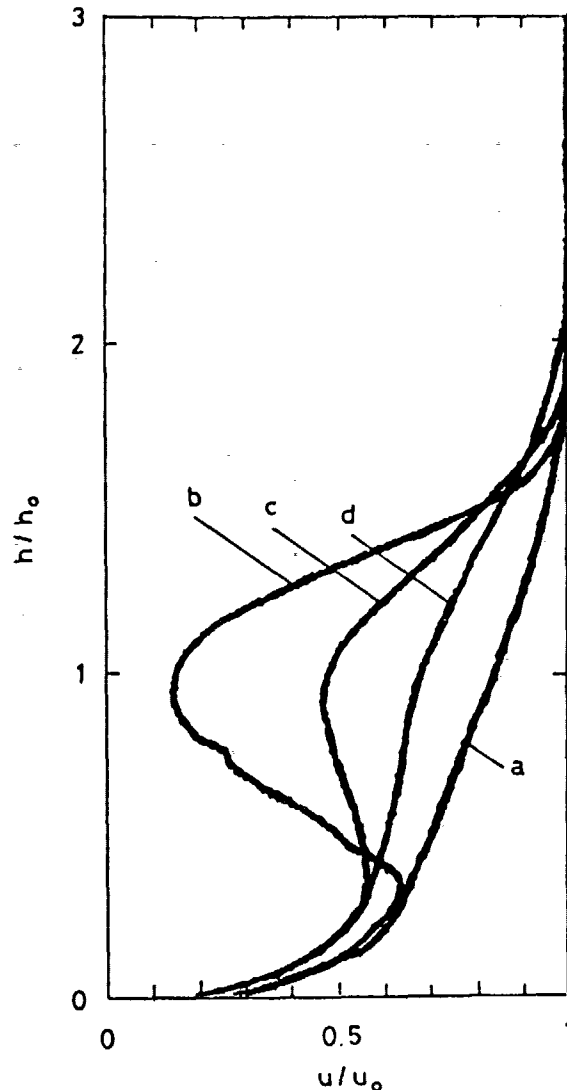

Figure 18 Wind profiles as function of distance from turbine (height in units of hub height, windspeed in units of speed at top of wind tunnel) a: Upwind. b, c and d: 2, 4 and 8 rotor diameters downwind.

Some wind conversion devices are perceived as possessing architectural or artistic beauty - eg sailships, old Dutch windmills and the tubular tower, slender blade, modern wind generators - while others are mainly considered as negative contributions to the visual environment.

The visual impact depends not only on the qualities of the individual machine, but also on its integration into the landscape, and particularly on the density of installations. It is considerably more difficult to configure a large wind-park in a way which blends favourably with the natural environment, than it is to site one or a few turbines in a given landscape.

Overhead transmission lines are usually considered a negative contribution to the visual environment, so in cases where landscape values are to be preserved despite wind turbine installation, the use of underground cables is required.

6. PRESENT DISSEMINATION OF WIND TECHNOLOGY

In order to be sure to have the most recent data on wind energy utilisation in Western Europe, I sent out a letter by November 1985 to the Departments of Energy in each of those European countries where I knew that some wind power activities were in progress. The replies received confirmed the overview given in the Summary, including the picture of Denmark as being the only European country with a significant number of operating wind generators. Some of the replies advised me to contact the Danish authorities, if I wanted to know more about wind power! There are fairly significant research and development programs in wind energy in several European countries. Some of them will be described below.

6.1 Manufacturers

Most European countries listed 5-20 local wind generator manufacturers. Except for Denmark and to some extent Holland and the UK, these are either manufacturers of mini-size farm windmills or they produce wind generators only for export to countries outside Europe (at least, they have not yet sold any machines in their own country). Several of the manufacturers have only a prototype turbine to show, and may never actually become producers.

About 15 European manufacturers have had substantial sales of small or medium size wind generators. They are located in Denmark, Holland, Belgium, Italy, UK and West Germany. The Danish manufacturers in 1985 had 38% of the world market; the other European producers a total of 14% [Windpower Monthly, 1985].

6.2 Installed Power

Most West European countries have one or a few experimental wind generators erected as part of government research programmes. Disregarding mini wind generators, the dissemination of commercial machines is presently 1500 wind turbines in Denmark, a growing number in the UK, Holland and Sweden, and none or close to none in the remaining countries.

Research regarding large wind generators and novel converter concepts is ongoing in Holland, West Germany, Sweden, Denmark and the UK.

6.3 Windfarms

The windfarm concept was developed in California. In Europe there are at present 12 operating windfarms in Denmark and one in Greece, another 10-20 are in the planning or construction stage in a number of European countries.

6.4 Export markets

European manufacturers have exported a substantial number of wind generators to the USA (mostly California) and have procured sporadic orders from Canada, South America, Australia and several developing countries. Intra-European exports of Danish and Dutch wind generators to the UK have taken place in small numbers.

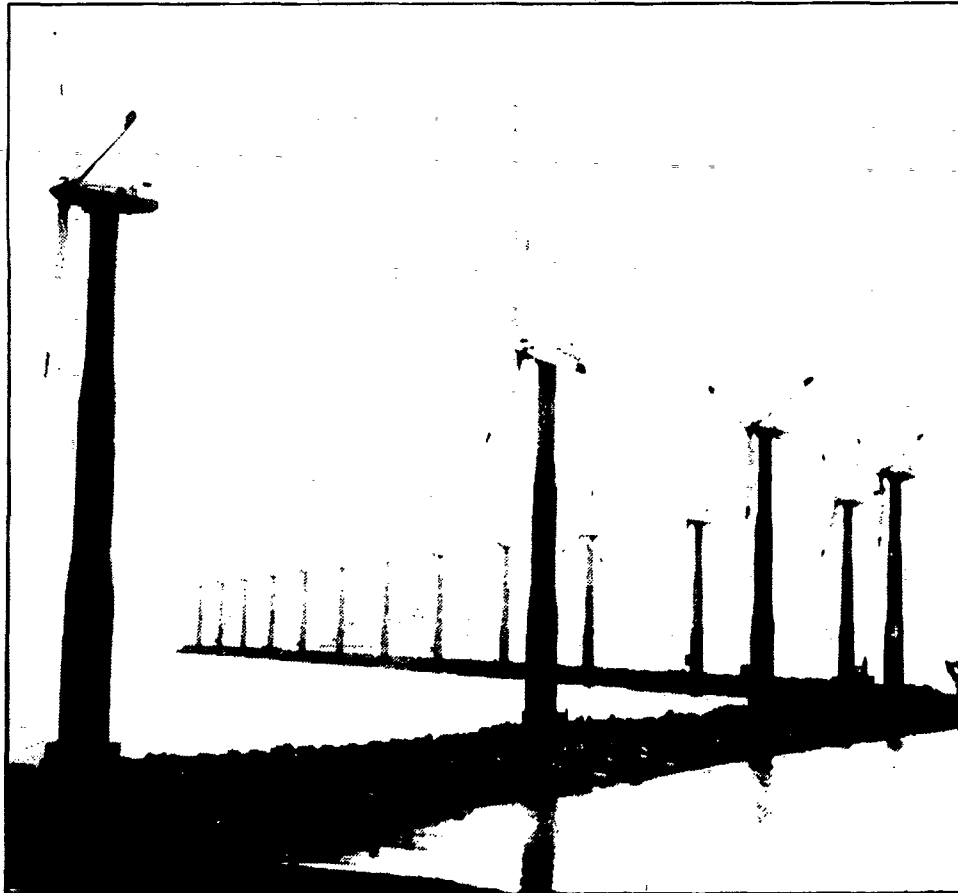

Figure 19 Ebeltoft off-shore windfarm (17 Nordtank generators with an annual power production of 3 GWh)

The most significant market so far has been the Californian one. The key figures illustrating the Californian wind power adventure are given in Table 3 [Merriam, 1986].

Table 3

END OF	1982	1983	1984	1985
Number of wind generators	2000	3800	8100	13500
MW installed capacity	-	239	583	1121
GWh produced annually	5	51	195	661

(dashed entries: data not available)

Changes in tax credit conditions are likely to curb the development in California, at least as far as imported generators (presently 50%) are concerned. This loss of market may be avoided if the sales price can be brought down to below 1000 US\$ per kW. Some manufacturers believe they can accomplish this (the Danish manufacturers sell at lower prices on their home market, cf. section 3.1)

New markets are being vigorously sought by the larger wind generator manufacturers. The Chinese government is establishing collaboration with Danish manufacturers, aiming at import and later indigenous production licencing. Some South American governments have shown similar interests. Many developing countries (with and without adequate wind resources) are being tempted by wind generator sales campaigns.

7. OPERATING EXPERIENCE

7.1 Reliability

Outage times for the early (1975-80) generation of small grid-connected wind generators were typically close to 10% [Sorensen, 1983], whereas outage periods for current Danish small-size wind turbines are less than 5%. A little over a third of Danish wind installation owners have agreed to take part in a detailed statistical effort, which is published monthly in the journal "Naturlig Energi/Windpower Monthly", in Danish and in English. The November 1985 issue finds an average of 4.2% of the wind generators out of commission. Typical causes were overheating and damage to yawing drive, failure to restart after cut-out in stormy conditions - often due to grid failure not turbine trouble - and routine service and blade angle adjustment, which seems often necessary during the first months of operation in order to avoid excessive overproduction. Of the 600 wind generator owners included in the survey, 96.2% returned the information requested.

7.2 Power Output

The average electric power production by the small Danish wind generators included in the above-mentioned statistical survey is 4-5 MW.

Capacity factors (actual production divided by constant production at rated power) of 15% to 35% are found depending on wind resource classification and wind year. The average capacity factor for 55 kW wind generators was 25%, that of 75 kW machines 27%, while the capacity factors of machines under 50 kW were all below 20%. One 265 kW turbine is operated in Denmark. Its latest capacity factor was 20%.

The wind generators surveyed, excluding those out of order for the entire period, produced power from 50% to 95% of the time.

The total monthly production of the 600 wind generators surveyed was 4.6 GWh or 0.25% of the Danish electricity consumption for that period. If the wind generators not included in the survey have similar power production per unit, the total wind power production would be 155 GWh annually or 0.7% of the total power consumption. This compares quite favourably with the production figures for US wind farms (section 6.4).

7.3 Site Evaluation

Annual energy production figures for small Danish wind generators are typically within 5% of the one estimated by the manufacturer for a particular site on the basis of the wind atlas method [Riso, 1980], once corrected for outage and for deviations in the wind climate of a particular year from the long-term average.

The wind atlas method uses eight sets of Weibull parameters to describe the wind conditions in eight directions of equally spaced angles.

If measurements were performed for each direction, they would enable the construction of frequency vs windspeed histograms, based on which a best fitting Weibull curve could be derived.

The wind atlas method instead uses visual estimates of roughness lengths in each of the eight directions to determine Weibull parameters as functions of height, using measurements at one location only, combined with the similarity theorems.

7.4 Quality of Power

Legislation and utility norms concerning quality of power were discussed in section 4.2. At the present level of penetration, wind generators in Europe have had no problems in complying with these regulations. In the case of larger wind farms, the construction of dedicated sub-stations is sometimes required.

7.5 System Aspects

At present levels of penetration in Europe (read: Denmark), the total average power produced by the wind generators can be credited to the utility system. This means that loss of load probabilities are the same as for a conventional system augmented with a conventional capacity equal to the average wind power production. In other words, the wind generators get a capacity credit equal to their average production, which in rough terms equals 25% of their rated power. This capacity credit figure was used in the national economy calculation example presented in section 3.7.

Should the penetration of wind power production reach and exceed 10%, the capacity credit would decrease rapidly [Haslett and Diesendorf, 1981].

The whole question of capacity credit and of back-up power for wind power systems depends very critically on system structure and grid interconnections to other systems. If the wind component can be matched to a hydro or gas fired system, not limited by generator capacity, then wind may be considered a source of firm power. This would be the case with a wind-hydro combination where the hydro system included seasonal reservoirs: the lending and borrowing of power implied by the variability of wind would be on a much shorter time-scale than the water level cycling of the hydro reservoir [Sorensen, 1981].

8. NON GRID-CONNECTED WIND GENERATORS

8.1 Wind-diesel

Wind-diesel combinations will be treated in a separate report [Sorensen, 1986], so they are not discussed further here.

8.2 Wind-batteries

Some mini-size wind generators provide DC to batteries, for use as stand-alone power sources in remote areas.

The use of batteries charged by wind generators for electric vehicles has been given considerable attention. In remote stand-alone systems this enables wind to replace fuel both for electric power needs and for transportation. The use of electric vehicles places a limit on the radius of operation. For small island communities, this solution seems ideal.

Even if a grid is present, the wind-battery concept may have a role, since it would allow power to be sold back to the utility company at peak load times [Jensen and Sorensen, 1984].

8.3 Wind-Solar

Experiments with wind-solar photovoltaic cell installations are ongoing in several countries, particularly with stand-alone applications (such as powering telecommunication links) in mind. The advantage of these systems is limited to regions, where the availability of sun plus wind is more evenly distributed than either one alone.

8.4 Wind-Biogas

The combination of wind with a biogas fired engine plus generator is similar to the wind-diesel combination, except that both sources would now be renewable and locally available, thereby avoiding the costly, long distance transport of diesel fuel. Experimental setups of this kind are in progress in Denmark and elsewhere. An alternative is to use fuel cells to efficiently convert the biogas [Jensen and Sorensen, 1984].

8.5 Wind-Natural Gas

Again the system is similar to wind-diesel. Either a gas engine or turbine would be feeding the electric generator. The advantage of this system would lie in regions endowed with natural gas and possessing the necessary infrastructure, but either not having electric utility grids or having local grids that would otherwise be charged by power generation from more expensive fuels. Under normal pricing conditions, natural gas pipelines would be more expensive than electric grids, so that it would pay to place the gas-fired generator centrally and use a local power grid to connect to the wind generator as well as the load site.

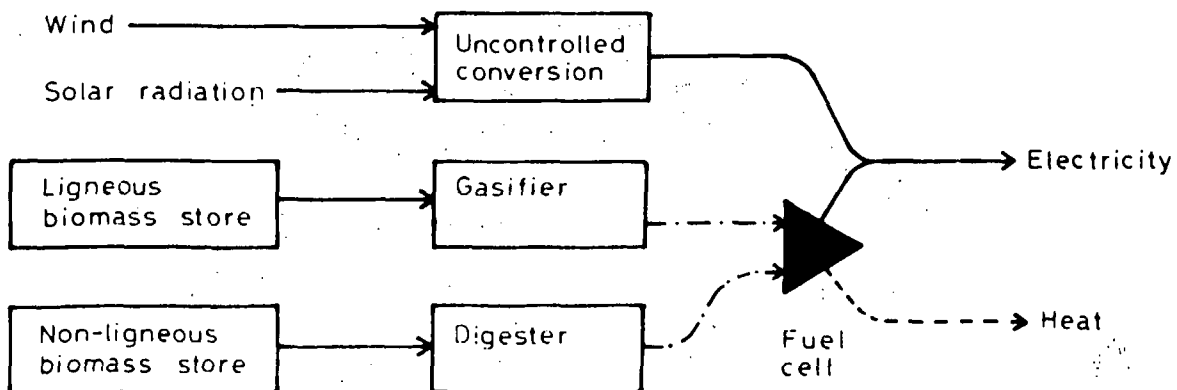

Figure 20 Possible use of fuel cells in wind (solar) - biomass stand alone energy system.

REFERENCES

- Alfredson P, Dahlberg J, and Bark F, 1980. In "Third Int. Symp. on Wind Energy Systems", BHRA Fluid Eng., Cranfield, pp 469 - 484
- Barker P, Bowden, G, Outhred H, Robins B, and Williams M, 1983. "Wind Energy Feasibility Study for Lord Howe Island", Energy Authority of New South Wales, Sydney.
- Buch L, 1977. Gedsermill. Report from South Sealand Electric Supply Undertakings (November 17).
- Hafnia, 1985. Hand i Hand Insurance Company, Copenhagen
- Haslett J and Diesendorf M, 1981. Solar Energy Vol 26, pp 391 - 401
- Hassan M and Klein J, 1981. "Distributed Photovoltaic Systems: Utility Interface Issues and their Present Status". Jet Propulsion Lab., Pasadena, No.81-89.
- International Energy Agency, 1982. "Recommended Practices for Wind Turbine Testing", Vol. 1: Power Performance Testing.
- International Energy Agency, 1984. "Recommended Practices for Wind Turbine Testing", Vol. 7: Quality of Power. Single grid-connected WECS.
- Jensen J and Sorensen B, 1984. Fundamentals of Energy Storage. Wiley, New York.
- Keast D 1978. "Noise-control Needs in the Developing Energy Technologies", US DOE Report COO-4389-1.
- Kelley N, Hemphill R and McKenna, 1982. J Solar Energy Eng., Vol. 104, pp 112-120
- Macqueen J, Ainslie J, Milborrow D, Turner D, and Swift-Hook D, 1983. IEE Proc. vol. 130-A, pp 574-586.
- Maeng H, Mortensen L and Hvelplund F, 1985. Status of Renewable Energy Investments (in Danish). Alborg University Press.
- Merriam M 1985. Private Comm.
- Riso, 1980. Windatlas Report.
- Riso, 1986. Windpark in Roskild, Report to Local Government of Roskilde (in Danish)
- Roger S, Cornaby B, Rodman C, Sticksel P and Tolle D, 1977. "Environmental Studies related to the Operation of Wind Energy Conversion Systems", US DOE Report COO-0092-77/2.
- Sengupta D, and Senior T, 1978. "Electromagnetic Interference by Wind Turbine Generators", US DOE Report TID-28828.

Sorensen B, 1979. Renewable Energy. Academic Press, London.

Sorensen B, 1981. Energy Policy, Vol.9, pp 51-55.

Sorensen B, 1983. "Recent Experience with Small Wind Converters", Chapter 36 in "The Future of Small Energy Resources" (R Meyer and J Olsen, eds.) McGraw-Hill, New York (pp 249-253).

Sorensen B, 1986. A study of Wind-Diesel/Gas Combination Systems, Energy Authority of NSW, Sydney.

United Nations, 1961. Proc. Conf. on New Sources of Energy (Rome), Vol.7 (reprinted 1974).

Windpower Monthly, 1985. October issue.

Zambrano T, and Gyatt G, 1983. IEE Proc. Vol.130, pp 562-565

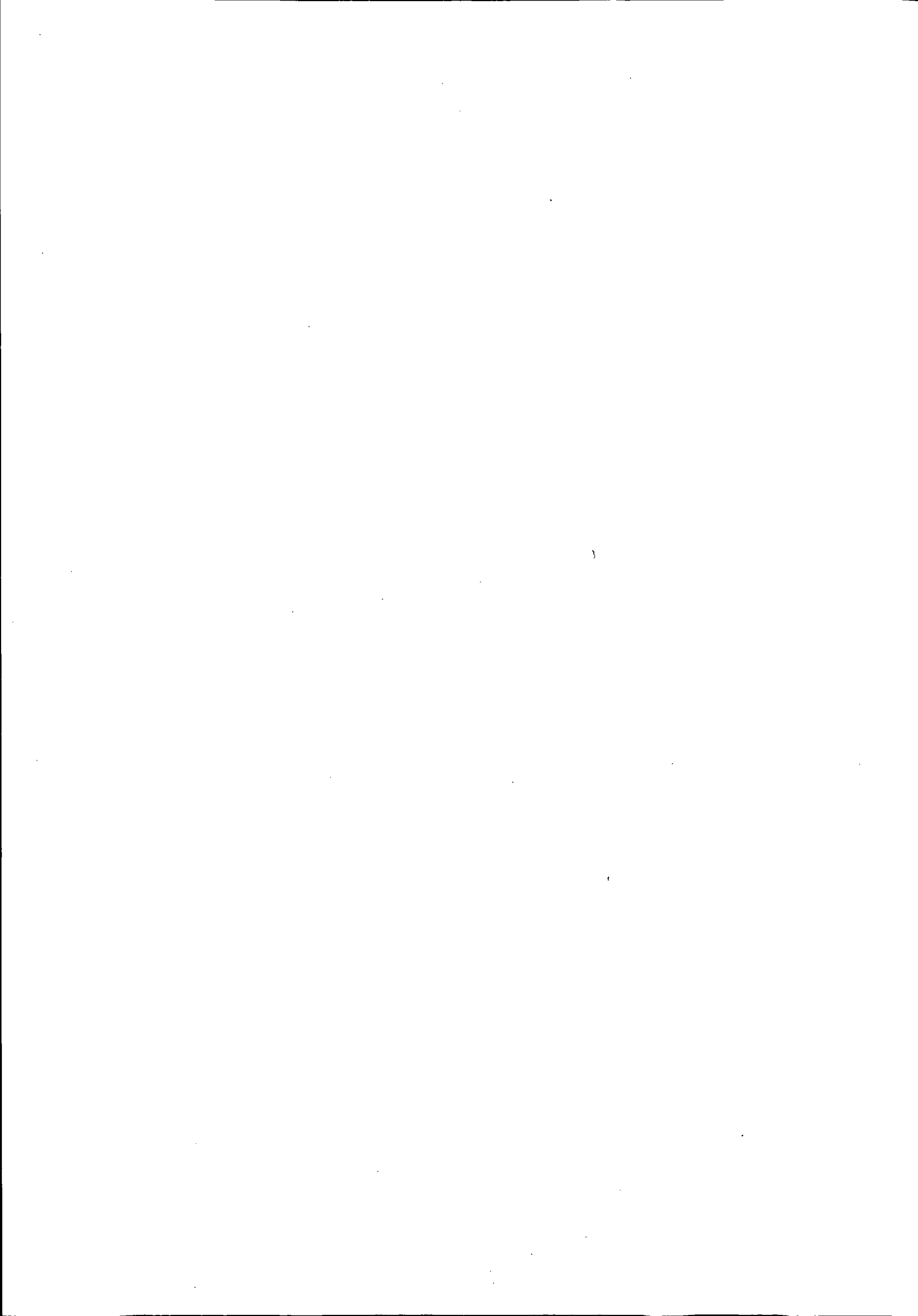

A STUDY OF WIND-DIESEL/GAS COMBINATION SYSTEMS

Bent Sorensen*

* Visiting Professor, School of Electrical Engineering and Computer Science, University of New South Wales.
Permanent affiliation: Roskilde University Centre, Denmark.

This report was commissioned by the Energy Authority of New South Wales as part of an ongoing programme of considering energy alternatives.

The views expressed are those of the Author and not necessarily those of the Energy Authority of New South Wales.

Energy Authority of New South Wales
1 Castlereagh Street
GPO Box 485
SYDNEY NSW 2001

Telephone (02) 234 4444

EA 86/17

ISBN 0 7305 1566 4

June 1986



CONTENTS

PAGE

1.	THE MALABAR PROJECT	1
2.	INTERNATIONAL SURVEY OF ONGOING WIND-DIESEL PROJECTS	3
2.1	European experience	3
2.1.1	Fair Isle (Scotland), Lundy Island (England) and Inis Oirr (Eire)	3
2.1.2	Hawker Siddeley/Imperial College/Rutherford Appleton Lab. collaboration (U. K.)	8
2.1.3	Energy Research Centre (The Netherlands)	16
2.1.4	Jutland and Riso (Denmark)	22
2.1.5	Kythnos (Greece)	26
2.1.6	Tristan da Cunha (Atlantic Ocean)	27
2.1.7	Fernando de Norunha (Brazil)	27
2.1.8	Martigny (Switzerland)	29
2.1.9	Other European projects	29
2.2	North American experience	31
2.2.1	United States	31
2.2.2	Canada	34
2.3	Australian experience	36
3.	CONFIGURATION CONSIDERATIONS AND OPERATIONAL STRATEGIES RELEVANT FOR NSW APPLICATIONS	37
3.1	Short-term behaviour	40
3.2	Modelling average behaviour	41
3.3	The Malabar Test Facility	43
4.	MODEL CALCULATIONS	44
4.1	Load pattern	44
4.2	Diesel engine fuel characteristics	45
4.3	Wind characteristics at Malabar	47
4.4	Wind turbine design	50
4.5	Power production	52
4.6	Fuel savings	53
4.7	Diesel starts in on/off mode	54
4.8	Economics of wind-diesel systems	57
4.9	Capital charge rate	59
4.10	Fuel cost	60
4.11	Wind turbine cost	60
4.12	Dependence on wind conditions	63
4.13	Sensitivity analysis	63

	PAGE
4.14 Frequency distributions	66
4.15 Placing international experiences in the model context	70
4.16 Discussion of the results and their implications for NSW projects	71
5. SUGGESTED EXPERIMENTS FOR THE MALABAR INSTALLATION	73
5.1 Phase 1: Grid-connected wind turbine	73
5.2 Phase 2: Wind turbine operated in conjunction with continuously running gas generator	74
5.3 Phase 3: Diesel engine added to system.	75
5.4 Phase 4: Wind turbine operated in conjunction with intermittently running gas generators	76
5.5 Supporting theoretical studies.	76
Appendix 1	77
References	81

ILLUSTRATIONS

PAGE

Figure 1	Malabar site	2
Figure 2	Fair Isle power system	4
Figure 3	Fair Isle power production	5
Figure 4	Lundy Island power system	6
Figure 5	Lundy Island power production	7
Figure 6	Inis Oirr power system	8
Figure 7	Experimental set-up at Rutherford Appleton laboratories	9
Figure 8	Measured performance of 16/6.4 kW wind diesel system with constant load 2kW	10
Figure 9	Measured diesel fuel use for parallel wind-diesel operation, relative to that of diesel-alone operation	10
Figure 10	a: Measured Speed and voltage during upstart with no load b: Response to full load application (from idling)	11
Figure 11	Measured diesel Fuel consumption as function of accumulated load	12
Figure 12	Most significant wear indicators, in ppm, as function of diesel running time	12
Figure 13	Diesel-wind systems with induction generator	13
Figure 14	Model output for wind diesel operation in worst case situation of wind speed near wind turbine cut-in speed	14
Figure 15	Calculated Fuel Savings for different modes of operation of wind-diesel system (diesel alone, diesel always on, intermittent diesel), plus number of starts in the latter mode	15
Figure 16	Total fuel consumption and number of starts per week for the larger diesel, as function of the percentage rating of the smaller diesel	16
Figure 17	ECN Verification system	17
Figure 18	Measured diesel fuel consumption	17
Figure 19	Measured cold start extra fuel consumption	18
Figure 20	Measured losses in "verification system" operated with diesel engine disconnected	18
Figure 21	ECN test site system	19
Figure 22	Measured 1 min averages at test site system, for 8 hours	20
Figure 23	Measured energy input flows and disposition for 218 hour period	20
Figure 24	Inferred energy flow for pure diesel system, for the same case as Figure 23	21
Figure 25	Wind/PV/diesel system of Jutland Telephone Co	22
Figure 26	Wind turbine and photovoltaic array at Olst, Jutland	23
Figure 27	Container for diesel set, battery store and controls	24
Figure 28	Riso "State of the art" system	25
Figure 29	Riso/Chalmers "advanced system"	26
Figure 30	Kythnos wind-diesel system	27
Figure 31	Natal test field installation	28
Figure 32	Frequency based control scheme	28
Figure 33	Martigny wind biogas system	29
Figure 34	Martigny installation	30
Figure 35	Block Island wind-diesel system	31
Figure 36	Measured fuel use, efficiency and fuel use slope for 3 diesel engine sizes	32
Figure 37	45 minutes of data recorded	33
Figure 38	fuel displacement	34
Figure 39	Wind-assisted diesel system at Sudbury	35
Figure 40	Sudbury wind-diesel fuel savings	35
Figure 41	Rottnest Island System	36
Figure 42	System considerations	37
Figure 43	System choice	38
Figure 44	Ratio of minimum and 10 minute average dual wind turbine output, as function of average wind speed	43

Figure 45	Malabar wind-diesel/gas system	44
Figure 46	Model of diurnal load variations	45
Figure 47	Assumed diesel fuel consumption as function of load	46
Figure 48	Measured Frequency distribution of wind speeds at Malabar	47
Figure 49	Measured hour-of-day average wind speeds at Malabar	48
Figure 50	Measured weekly average wind speeds at Malabar	48
Figure 51	Measured directional frequency distributions of winds speeds at Malabar	49
Figure 52	Measured frequency distributions of wind speeds at Malabar	50
Figure 53	Frequency distribution of power in the wind at Malabar	51
Figure 54	Power curve used in simulation study, and power curve of HMZ turbine	51
Figure 55	Rated power vs swept area for selected wind turbines	52
Figure 56	Simulation results of electric power production by wind and by diesel	53
Figure 57	Fuel use for diesel alone, for grid-connected wind turbine, and for two modes of wind-diesel operation	54
Figure 58	Number of diesel starts and percent of time diesel is off	55
Figure 59	Number of diesel starts for 200m ² wind swept area	55
Figure 60	Number of diesel starts and percent of time diesel is off	56
Figure 61	Base-case energy costs for wind-diesel systems in different modes of operation	58
Figure 62	Energy costs for wind plus intermittently operated diesel system	59
Figure 63	Energy costs for wind plus intermittently operated diesel system, for 3 different diesel fuel prices	60
Figure 64	Specific cost of wind turbine and diesel interface equipment as function of area swept	61
Figure 65	Energy costs for wind plus intermittently operated diesel system, for two different specific wind turbine costs	61
Figure 66	Energy costs for wind-diesel system using realistic wind turbine costs and assuming either continuous diesel operation or on-off operation	62
Figure 67	Comparison of wind-diesel model results using actual Malabar wind data or a standard Weibull distribution of k=1.85	64
Figure 68	Spider diagram of the model's parameter sensitivity at the economic optimum point	64
Figure 69	Calculated energy cost for wind-diesel system using realistic wind turbine cost and power curve of figure 54	66
Figure 70	Time-distribution of wind turbine output	66
Figure 71	Time-distribution of wind turbine output for different average windspeed regimes	67
Figure 72	Time-distribution of diesel output, for base-case mode 3 operation of wind-diesel system with different sizes of wind turbines	68
Figure 73	Time-distribution of variable costs, for base-case mode 3 operation of wind-diesel system with different sizes of wind turbines	69
Figure 74	Comparison of model calculation wind power production, diesel prouduction, power dumped and fuel used, with actual wind-diesel systems	70
Figure 75	Grid-connected wind turbine	73
Figure 76	Wind turbine operated in conjunction with continously running gas generator	74
Figure 77	Diesel engine added to system	75
Figure 78	Wind turbine operated in conjunction with intermittently running gas or diesel generator	76
Table 1	Operation and control strategies	40

SUMMARY

The report discusses technical and economic aspects of a wind-diesel/gas engine test facility under construction at Malabar near Sydney. Based on an assessment of similar international projects, it is suggested that the Malabar experiments be divided into four phases:

1. Wind generator connected to public power grid.
2. Wind turbine and gas engine isolated from grid, feeding into a programmable dump load which may be used to simulate actual load patterns of remote NSW communities. The gas engine runs continuously.
3. Diesel engine added to system, either for wind-diesel isolated operation or using the diesel and gas engines to study the operation mode in which a small engine is run continuously and a larger one is run intermittently.
4. Wind turbine modified to allow intermittent operation of the gas engine, by means of a controllable capacitor bank and possibly a battery storage facility capable of supporting the load for a minimum of 10 seconds while the engine is started.

The experiments should aim at elucidating possible technical problems related to light load diesel/gas operation and power quality during switching between wind and fuel-based generation or vice versa. It is furthermore suggested that the experiments aim at collecting operational data sufficient for validation of computer simulation models of the system. This will enable a transfer of the wind-diesel technological experience from the specific site at Malabar to other locations in NSW or elsewhere.

A preliminary model simulating the average behaviour of wind-diesel systems similar to the one at Malabar has been used to assess the economic aspects of wind-diesel combination. At current international cost levels it is concluded that the viability of wind-diesel systems requires:

- (a) Average site wind speeds above 6 metres per second. If other conditions are favourable, 5-6 m/s average wind speeds may be acceptable.
- (b) Diesel fuel costs at the site should exceed 70 Aus. cents per litre for the addition of wind turbines to be economically advantageous.
- (c) Wind turbine rotor swept areas should be chosen in the interval of 4-6 square metres per kilowatt of average consumer load.
- (d) Current cost-size relationships suggest that each wind turbine should have a rotor swept area of 200-300 square metres. Larger requirements should be met by multiple units.

(ii)

When these conditions are satisfied, fuel savings of about 30% and power cost reductions in excess of 10% can be expected if the system is constructed to allow intermittent diesel operation. With continuous diesel operation, about a third of the cost reduction is lost, despite lower system investment costs.

If there are consumer loads which are not time-urgent and which therefore may be displaced in time, larger wind shares in the system can be accepted, and savings may increase.

It is expected that gas engines could replace diesel engines if the fuel cost is similar or lower.

The incorporation of wind turbines in fuel based power systems may also provide non-economic advantages, such as reduced dependence on world market prices for oil products and environmental benefits.

The Australian market situation for wind turbines is such that imported machines have difficulties in meeting the required cost goals.

1. THE MALABAR PROJECT

The Energy Authority of New South Wales is establishing a test facility at Malabar headland near Sydney (see Figure 1), with the purpose of simulating isolated community power supply on the basis of a wind generator operated in conjunction with diesel or gas generators.

As 100-200kW is representative of the loads of the remote area communities aimed for, a 150kW (rated power) wind turbine was purchased and is expected to be installed early in 1986.

It is expected that suitable gas and diesel generators for the interconnection experiments can be borrowed or hired from manufacturers, and funds for an initial test program have been secured.

The equipment expected to be available for the test facility includes:

- (a) 150kW Wind generator, type HMZ, rotor diameter 21.8m, with hydraulic and electronic blade pitch control and equipped with induction generator providing 3 phase, 415V AC power at 50Hz.
- (b) 200kVA 415V/11kV transformer allowing wind power to be fed into the existing 11kV line between the Metropolitan Water, Sewerage and Drainage Board (MWS & DB) treatment plant and two fans (2 x 25kW) operated by the Board on Malabar headland.
- (c) 132kW propane or natural gas engine (G.E.C. Dorman 6PG, 4 stroke, 6 cylinder, 2.65 litres, electric rating 120kW).
- (d) 50-150kW diesel engine (replaceable ?)
- (e) 150kW controllable resistive load (G.E.C.?) and associated 415V/11kV transformer.
- (f) Weather station, including wind speed measurements at different heights.
- (g) Control computer (HP 86 B).

Initial tests of the wind generator would be in a grid-connected mode. Later, the wind generator would be disconnected from the main grid and operated with a gas or diesel generator in various modes. The controllable dump load may allow experiments that simulate diesel on-off operation as well as rapid frequency sensitive load control.

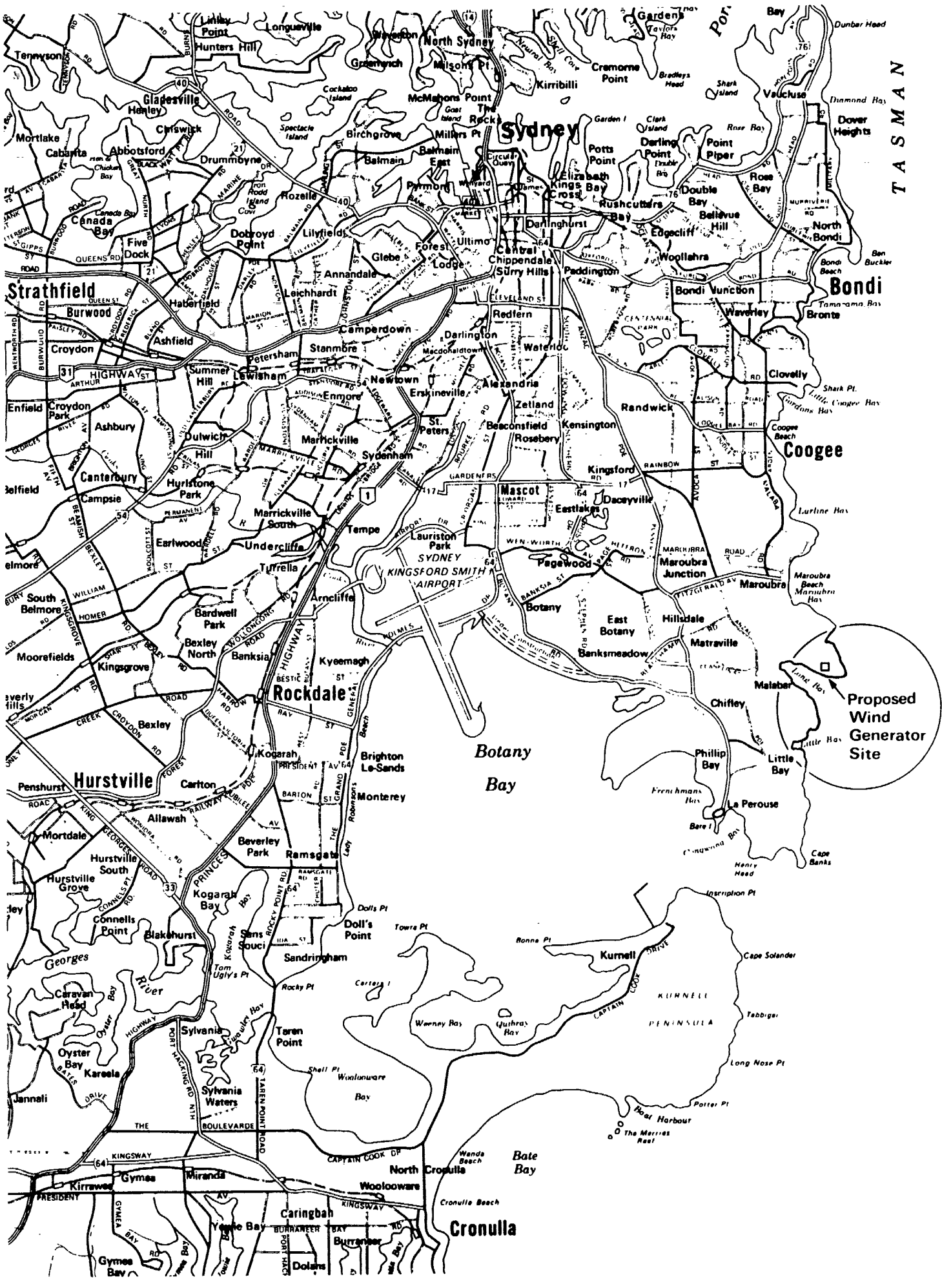

Figure 1. Malabar Site.

2. INTERNATIONAL SURVEY OF ONGOING WIND-DIESEL PROJECTS

A large variety of system combinations and operation strategies have been and are being tried out in connection with experimental wind-diesel installations worldwide. For this reason a brief survey of these projects may serve as a useful background for selecting experiments of relevance to the NSW situation. Household size wind-diesel combinations used in many remote areas have not been included, except when they serve as a test facility for some non-standard set-up or operational mode.

2.1 European Experience

2.1.1 Fair Isle (Scotland), Lundy Island (England) and Inis Oirr (Eire)

These three installations are based on Windmatic (14m rotor diameter) wind turbines and synchronous generators with voltage control based on frequency sensitive switches designed by the Northern Engineering Industries' subsidiaries Clark Chapman and International Research and Development Co. Frequency-sensitive load control is a special feature of the Fair and Lundy Islands projects, and one that makes these projects extraordinarily successful in terms of high diesel displacement by wind power.

There is a widespread power utility interest in load control based on signals sent through the distribution grid to non-essential load devices equipped with suitable control receptors. Such signals may take many forms, and the use of the basic grid frequency to transmit signals would by most large electric utilities be considered a very crude approach - at variance with the frequency stability criteria believed to be necessary for maintaining acceptable power quality [cf. Sorensen, 1986]. However, the island grids, into which the wind-diesel systems considered here are incorporated, have had no objections to the $\pm 10\%$ frequency excursions and even short black-outs during system switching, presumably because the original diesel system provided no better power quality.

Fair Isle

The Fair Isle system is depicted in Figure 2. The wind generator was installed in June 1982. Some 20 households (population: 74) are connected to the system, which has two independent grids for service loads and for the frequency-controlled heat loads. A controlled dump load is included for the case when all other loads are saturated and still more wind power is being produced. There are plans to replace this dump by a non-essential horticultural load, in which case no wind produced power would be wasted.

Each consumer can, through light indicators see the conditions of the system, and may adjust his/her service load according to whether power is produced by wind or by the far more expensive diesel generators (as in most isolated small island cases, transportation costs make diesel fuel very expensive). 1985 tariffs at Fair Isle were 6p/kWh for diesel power, 2 p/kWh for wind power to service loads, 1.5p/kWh for controllable heat loads (1p \approx 2.2A¢) [Somerville and Stevenson, 1985].

The service loads of up to 40kW are without frequency control. If the frequency falls below 45Hz, the grid is disconnected and a diesel set is started. When the frequency goes above 50Hz, the controlled heat loads are switched on in a staggered sequence. The full heat load of 75kW is reached at 51.5Hz, but if heat take-off is insufficient and hot water storage tanks are full, then additional power production is dumped (the dump load is switched on in a staggered sequence between 52 and 53.5Hz). The power rating of the dump load is 75kW, capable of absorbing the total power output from the wind generator.

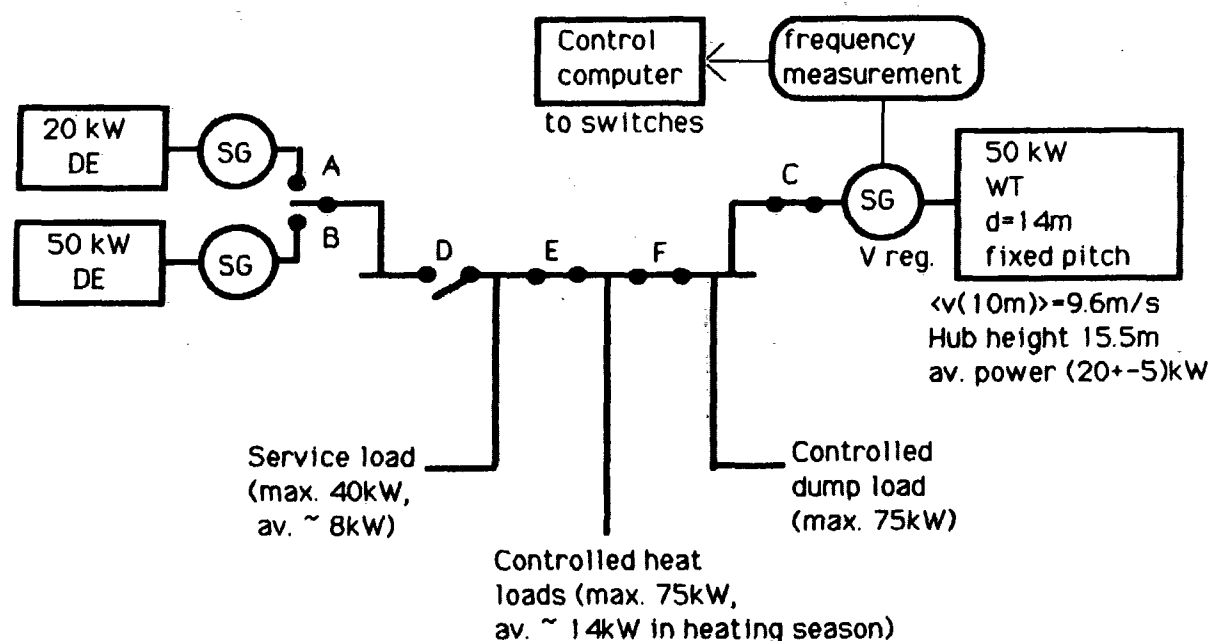

Figure 2. Fair Isle power system. Abbreviations:
DE = Diesel Engine, WT = Wind Turbine, SG = Synchronous Generator.

The wind turbine and the diesel sets are not allowed to run in parallel. Reasons given for this decision are:

- i) this will maximise fuel savings according to experiments performed earlier, and
- ii) light load running of diesel sets will be minimised, believed to ensure longer life and lower operation and maintenance costs [Somerville and Stevenson, 1985].

In practice this policy is implemented by never allowing all three switches D, E and F in Figure 2 to be closed. If there is enough wind to cover service loads, and both diesel engines are off, then switches E and F are closed. If later the frequency drops below 45Hz, switch E is opened and a diesel engine is started, after which switch D can be closed. Note that this involves a few seconds without grid power. When the 20kW diesel engine is operating, and the wind power production would exceed load by at least 10kW, then switch A is opened and E, F closed. Operating experience with the Fair Isle system is summarised in Figure 3. After a few months of operation, the gear box of the wind turbine had to be replaced. This caused an outage period of 55 days. At the time of replacement, the wind machine was derated from 55kW to 45kW, because overproduction up to power levels of about 75kW had been experienced (and might have caused the damage to the gear box). During another outage period in 1983, where the alternator had to be replaced by a moisture proof type, the power rating was raised to 50kW [Sinclair et al 1984]. The changes in rating were accomplished by altering the shaft speed. It was noted that lowering the shaft speed made the turbine start at lower windspeeds, and this speed change has later been used to seasonally select the most favourable power curve, in terms of the balance between number of operating hours and maximum power production [Somerville and Stevenson, 1985].

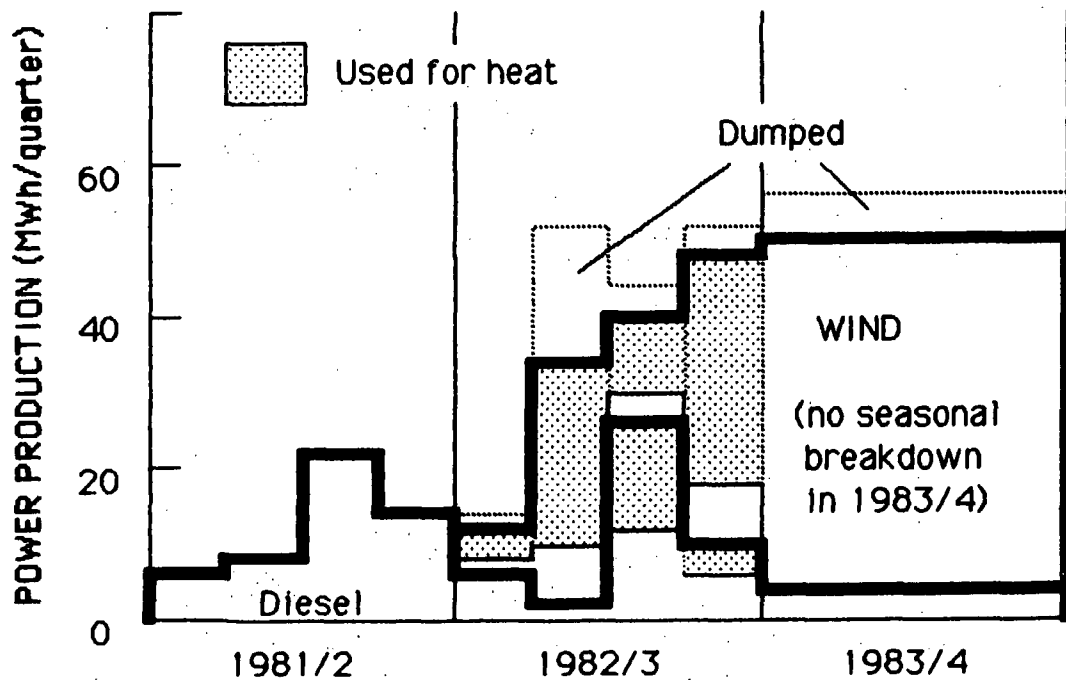

Figure 3. Fair Isle power production during 3 consecutive years, without wind power, with upstart of wind turbine and new control strategies, and finally a "normal production" year.

Figure 3 shows that the installation of the wind turbine has allowed power consumption on the island to rise (to an average of 285W/capita, which is comparable to typical residential electricity use in Europe), and that wind

power is now providing 91.3% of the load, while only 11% of the wind-produced energy is dumped. The diesel engines were stopped during 6779 hours in 1982/83 and presumably even longer in 1983/84. The light-load operation of the diesel engines have increased somewhat. The average fuel use in 1981/82, before the wind turbines were installed, was 0.0827 gallons per kWh, whereas it was 0.0885 gallons per kWh in 1982/83, corresponding to a 7% drop in average efficiency [Sinclair et al, 1984].

The main characteristics of the Fair Isle system, which contributes strongly to its operating success, are a large wind generator relative to average service load, many operating hours due to excellent wind conditions, and a large quantity of controllable and storage-type loads. The two available sizes of diesel engines fit nicely into the operating strategy, and the co-operation of the customers in accepting power quality irregularities and in managing service loads according to power production costs tops the list.

Lundy Island

The Lundy system, illustrated in Figure 4, is very similar to the Fair Isle one. It serves about 25 residents plus summer tourism. The wind generator was installed in November 1982. Wind conditions are not as favourable as on Fair Island, the average wind speed being around 6m/s, but the method of incorporating frequency-controlled heat loads in the system was again used successfully to augment utilisation of wind-produced power. The (single-phase) grids for service and controlled heat loads are not separated as in Fair Isle, so heating units with built-in automatic frequency-triggered controls had to be provided. These are storage heaters that can be charged in 2-4 hours. Later, it is planned to add a 90kWh phase-change store, in connection with a system extension that will also involve recovering 15kW of reject heat from the 27kW diesel engine and piping it to nearby consumers [Infield and Puddy, 1984]. Even without these additions, the thermal storage capacity in the system amounts to 40 hours of average wind generator output, or roughly 1000kWh.

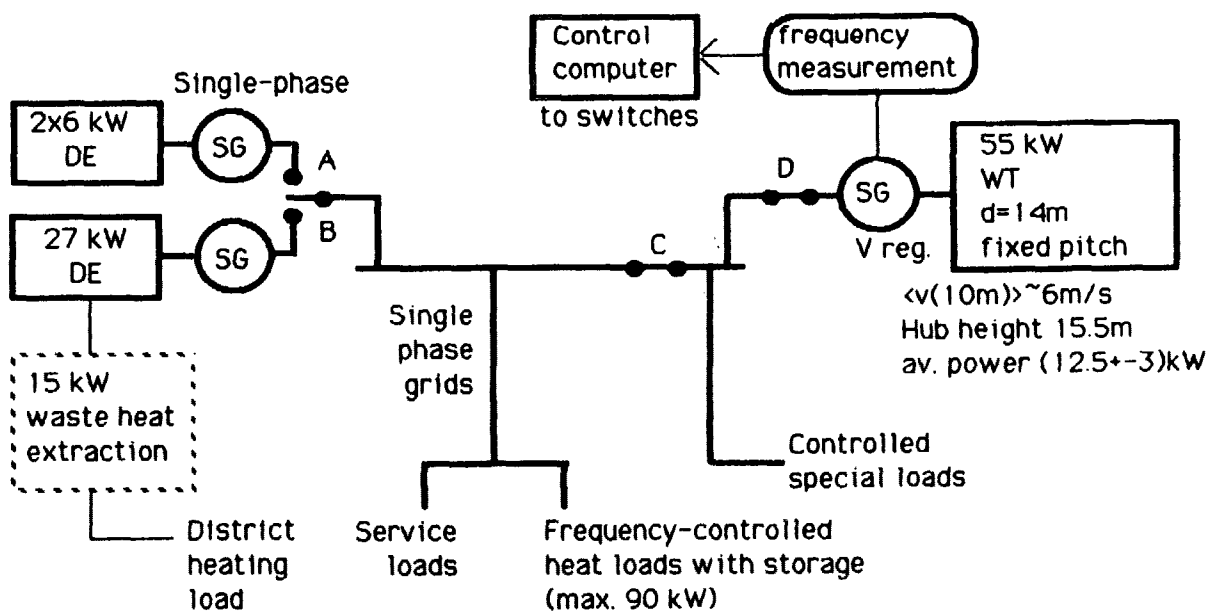

Figure 4 Lundy Island power system [Infield and Puddy, 1984]

As on Fair Isle, it has been decided not to allow parallel operation of wind and diesel. This means that the frequency-controlled heat loads on the customer grids are unavailable to the wind generator, if any of the diesel generators are operating. However, a few storage heaters have been connected on the wind generator side of Switch C (on Figure 4) and the new storage facility is also planned to be connected on that side.

Figure 5 shows available data on operating experience. During the first 100 days, the wind turbine was out of service for 5 days, provided no power on another 5 days and some power for 70 days. During 30 days the diesel sets did not have to be started at all. These figures pertain to the Winter season. Figure 5 indicates a strong seasonal variation in the wind resource, with 4 times high average power production during the 3 Winter months than during the following 6 Spring and Summer months.

Some 25% of the wind-produced energy was dumped. The higher dump figure as compared with Fair Isle is easily understood in terms of the abovementioned restrictions on wind power access to heat storage loads. Diesel fuel used during the first 100 days of operating the combined system amounted to 0.0619 gallons per kWh generated. The corresponding figure before installation of the wind turbine is not available, but it is probably similar, because the availability of 3 small diesel engines would allow operation to be at 70-80% of rated power everytime the diesel sets are called upon.

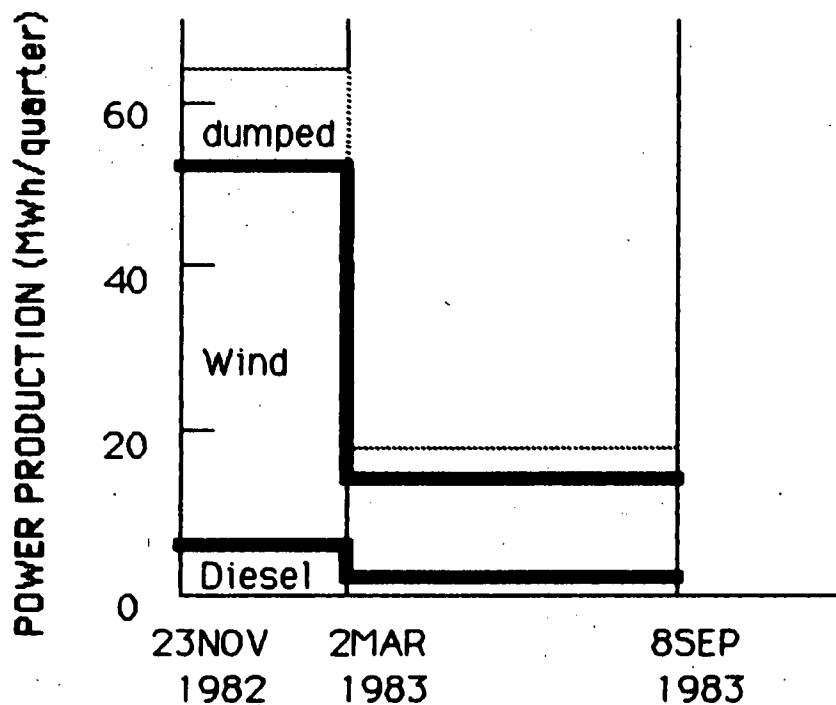

Figure 5. Lundy Island power production during first 9.5 months of wind-diesel operation.

The Lundy system is remarkable for performing nearly as well as the Fair Isle system despite the less favourable wind conditions. It shows that the success of the system and control strategy is not limited to localities with very high winds, but is rather related to the possibility of dividing loads into a relatively small portion of priority loads plus a much larger portion of non time-urgent loads, which may absorb the wind-produced power when it is there.

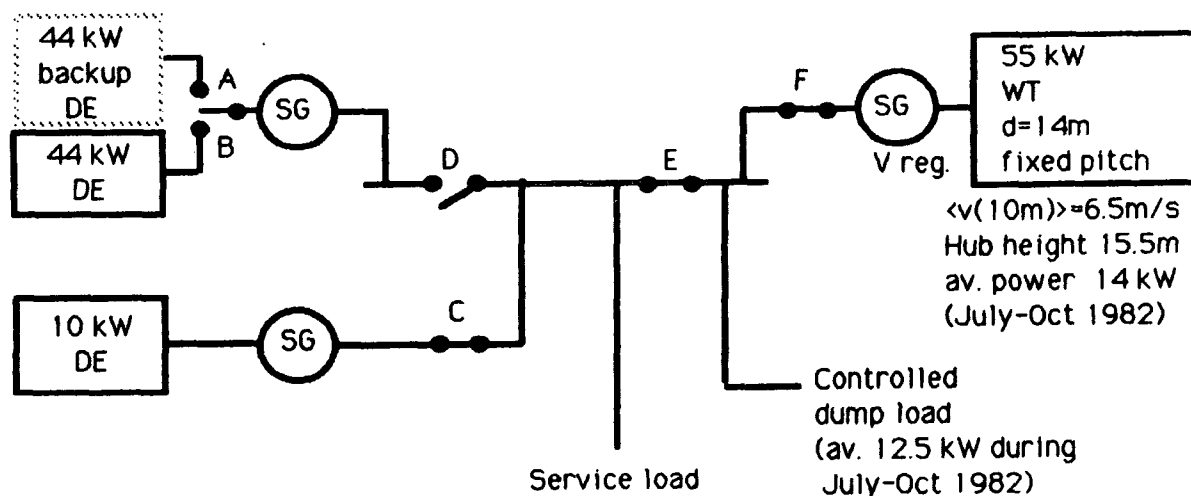

Figure 6. Inis Oirr power system
[Infield et al 1983]

Inis Oirr

The conclusion made above is highlighted by considering the Inis Oirr system, shown in Figure 6, and its performance. During three early Autumn months in 1982, 89% of the 14kW average wind-produced power had to be dumped. The system is similar to that at Fair and Lundy Islands except that no controllable heat load or storage is incorporated. The decision never to run diesel and wind in parallel seems ill taken in this case.

2.1.2 Hawker Siddeley/Imperial College/Rutherford Appleton Lab collaboration (U.K.)

The collaboration comprises extensive simulation studies as well as experimental work on parallel operation of wind and diesel, to be supplemented later by inclusion of a flywheel energy store [Lipman, 1985; Infield et al, 1985].

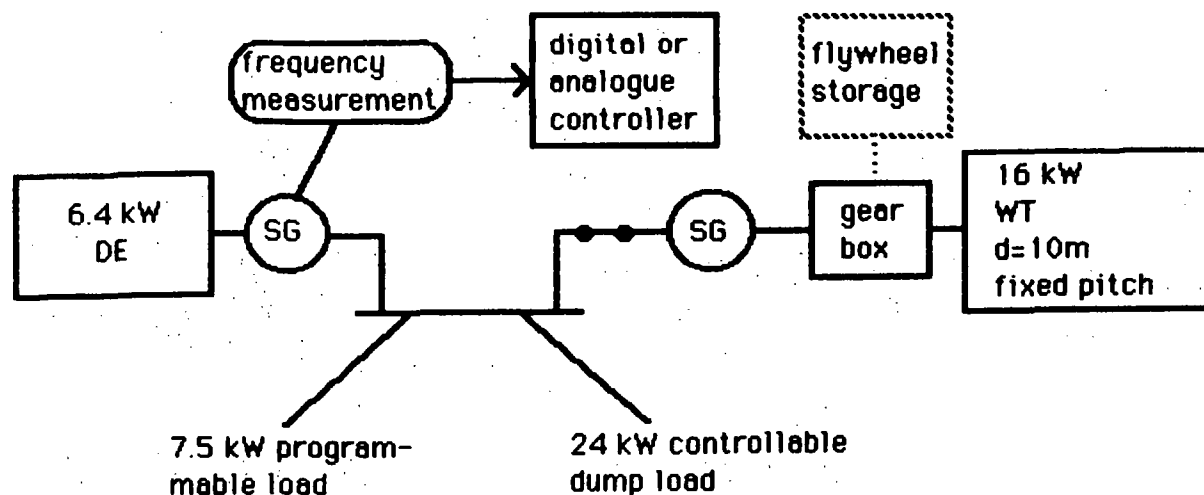

Figure 7. Experimental set-up at Rutherford Appleton laboratories.

The current experimental set-up is illustrated in Figure 7. Results from the first 70 hours of testing have been reported [Infield et al 1985]. The diesel set is not allowed to operate below a certain minimum load, $P_m = 20\%$ or 40% of rated power. Figure 8 shows examples of the results, for a constant "consumer" load of 2kW, and with both diesel and wind turbine operating in parallel. The 70 hourly means of diesel fuel use have been rearranged according to mean wind speeds in Figure 9 (for a 6kW load). There is an approximately 10% extra fuel use at low wind speeds, associated with situations where the diesel engine motors the wind turbine. At high windspeeds, the fuel saving depends on the minimum load allowed for the diesel. If there were no minimum requirement, the curve would eventually flatten out and assume the value of the idling fuel consumption. This would in the present case happen at the wind speed corresponding to 6kW power output, presumably around 8m/s.

Parallel System Performance 2kW load

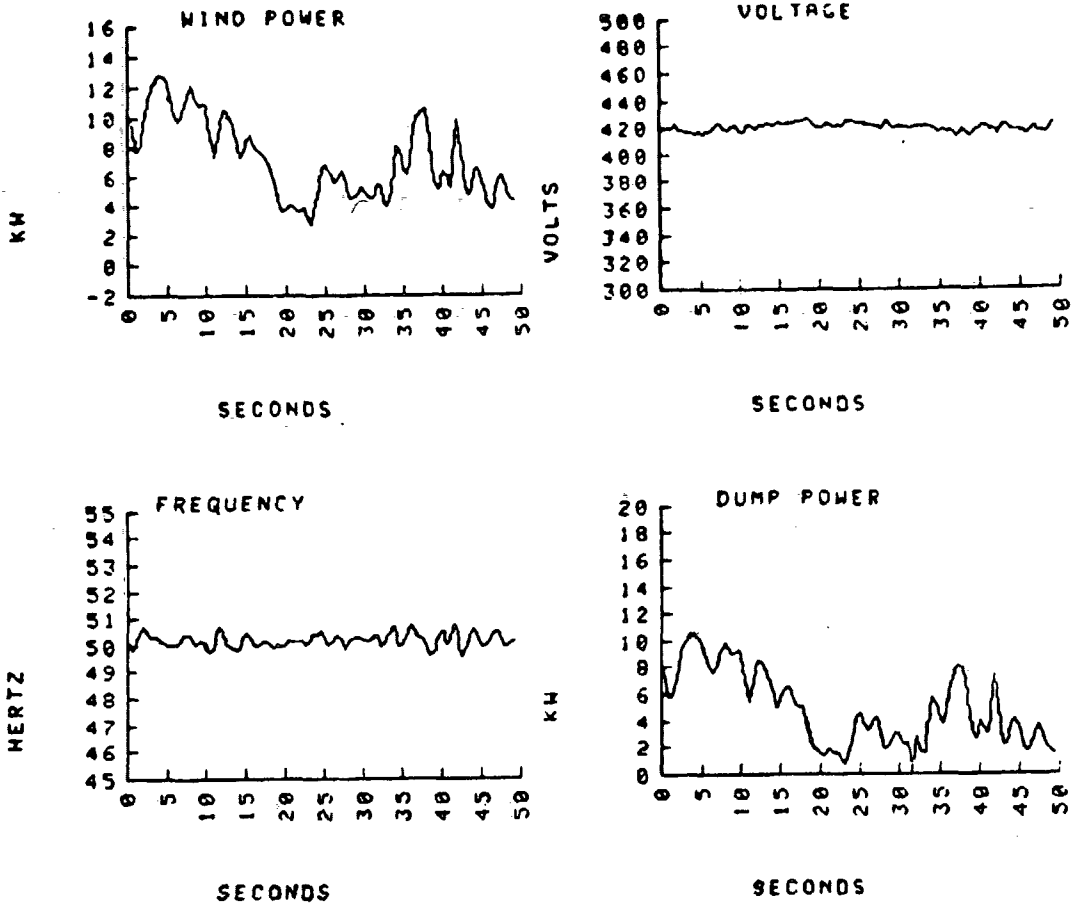

Figure 8. Measured performance of 16/6.4kW wind-diesel system with constant load 2kW. (The diesel engine seems to be off the period shown)

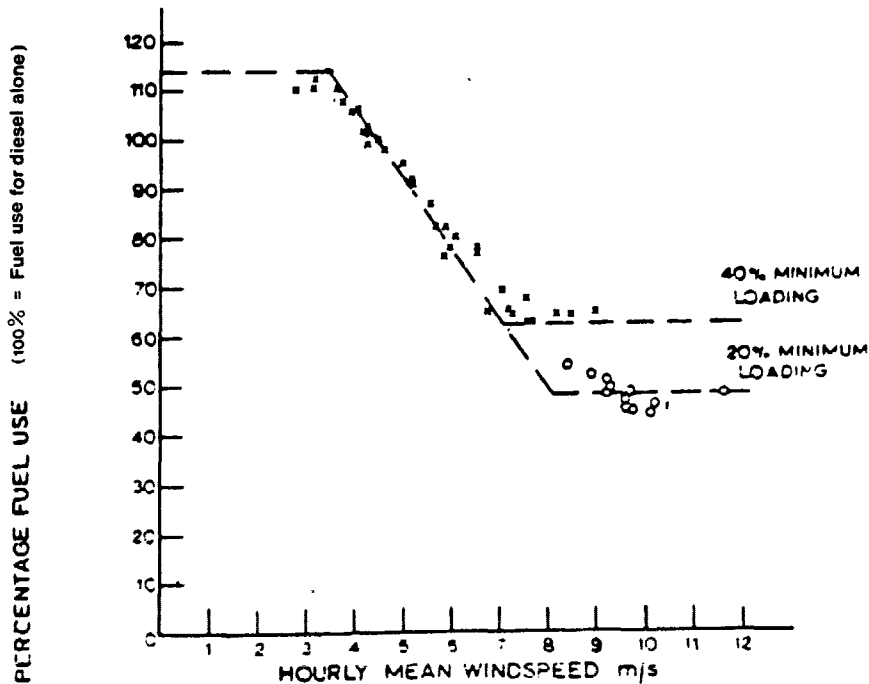

Figure 9. Measured diesel fuel use for parallel wind-diesel operation, relative to that of diesel-alone operation. The load was a constant 6kW.

Figures 10a, b show the characteristics of the HSPP Nova II diesel set used: Upstart time 7 seconds, recovering steady state after full load application in 4 seconds (with small frequency deviations for another 5 seconds). The ability to reproduce these features by simple computer models is also indicated.

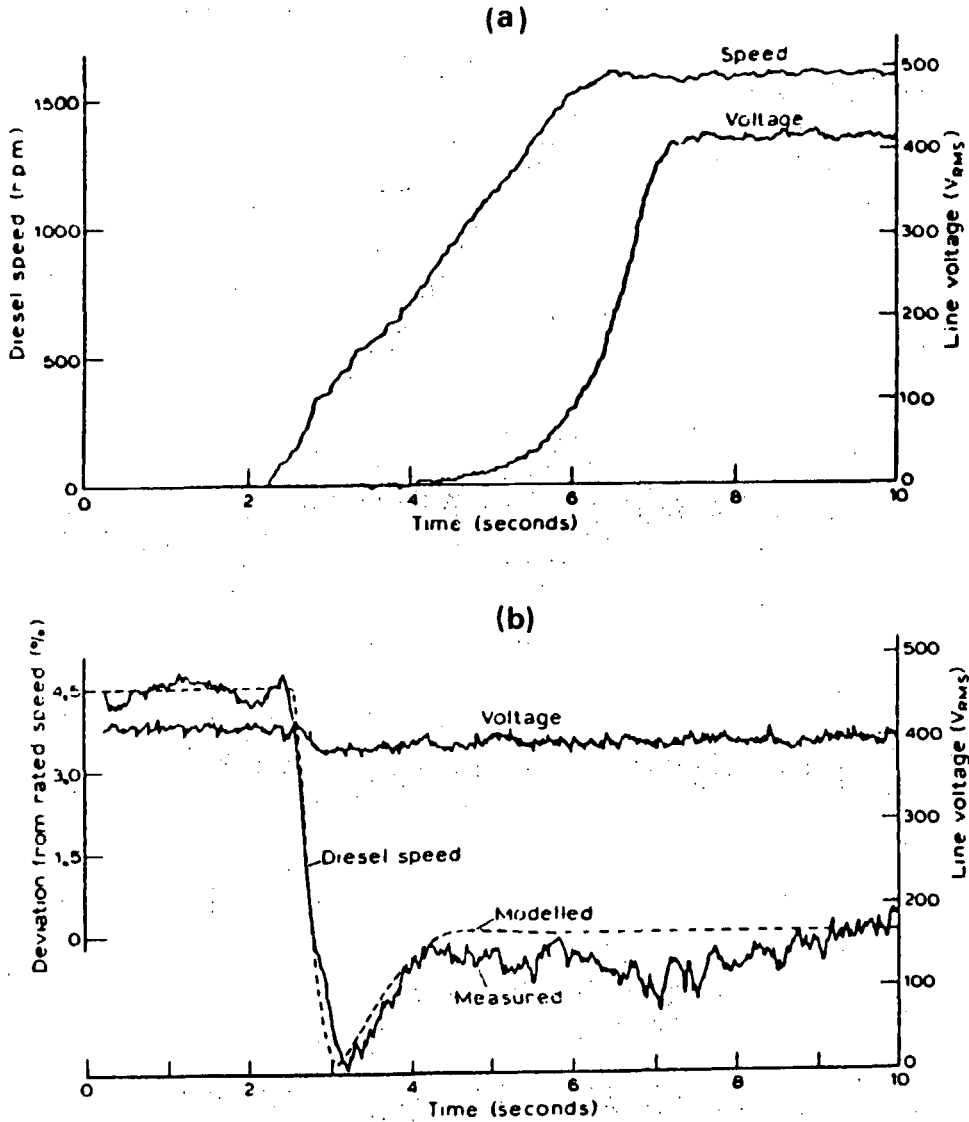

Figure 10. a: Measured speed and voltage during upstart with no load.
b: Response to full load application (from idling)

One option in parallel operation has been looked into by the British group, i.e. that of keeping the diesel connected at all times, but cutting its fuel supply when the wind power production exceeded load. In this case the wind generator is motoring the diesel engine, partly or fully providing power to compensate for the losses of the engine. Experiments revealed steeply rising losses, reaching 70% of the diesel rated output for a 4% increase in grid frequency. It is concluded that this mode of operation is not suited, unless the diesel speed can be lowered when the diesel is being motored by the wind generator.

Measurements of increased diesel fuel use due to on-off cycling were made. Fig. 11 shows fuel use as function of accumulated power production, either for continuous operation at 6kW, or with 10 on-off cycles per hour (4.5 minutes on, 1.5 minutes off). A 7% increase in fuel use per kWh generated is indicated for the rapid cycling case.

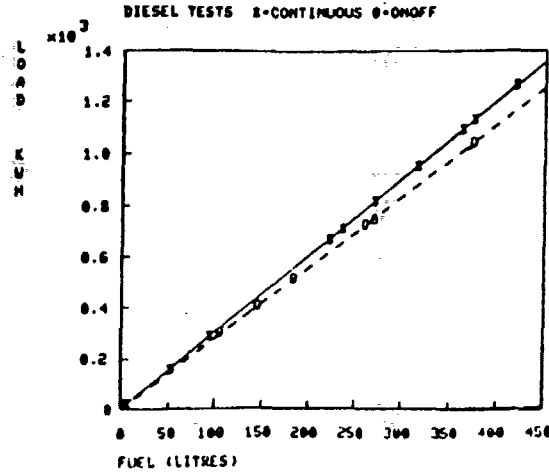

Figure 11. Measured diesel fuel consumption as function of accumulated load, for continuous operation (full line) or 10 on-off cycles per hour (dashed line).

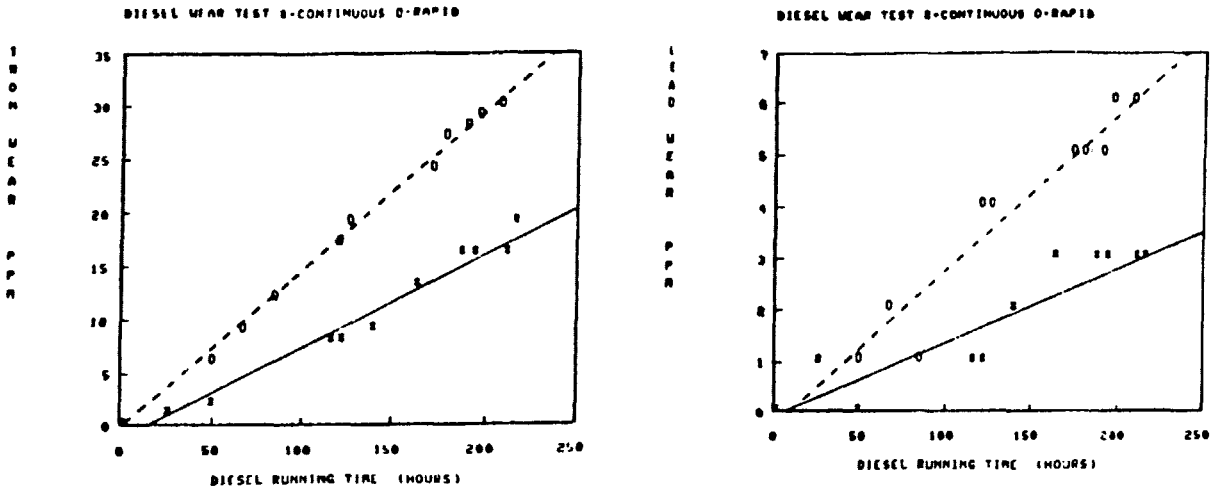

Figure 12. Most significant wear indicators (iron and lead), in ppm as function of diesel running time (circles: continuous operation, crosses: 10 on/off cycles per hour).

Figures 12 a, b show measured concentrations of iron and lead in sump oil, as a function of diesel running time for continuous and rapid on-off cycling as above. The wear is noticeably higher at cycling rates of $10h^{-1}$, but even after 2500 cycles the levels are within the tolerance limits specified by the diesel manufacturer. It is concluded that 10 on-off cycles per hour is probably acceptable.

The British group has supplemented their experiments with a number of computer simulation studies. Figure 10b shows an example of the validation of the diesel transient behaviour model. A model of steady state behaviour of the system depicted in Figure 7 shows that the system frequency can be kept within 0.1Hz as long as the diesel is running and the total power output is usable. When the diesel is shut off, the dump load control option becomes essential, and due to the finite steps involved, the frequency scatter is increased to about the 1% level.

Original modelling of this kind was made by Tsitsovits and Freris [1983], for a slightly different system (Figure 13). It assumed an induction generator for the wind generator, as is common for many commercial machines, supplemented by a two-stage capacitor to provide excitation. In conjunction with this feature, a clutch was inserted between the diesel engine and its synchronous generator, which would then function as a synchronous capacitor. The thyristor-controlled rectifier plus dump load may be replaced by a two way AC/DC converter plus energy store. The simulation study concluded that both parallel and pure wind turbine operation with this system was possible, with frequency fluctuations kept within 10.5% when assuming simultaneous control of dump load and wind turbine pitch angle. The pitch angle control was limited to 2 degrees per second. Presumably the pitch angle variability is not essential for this purpose, but added for security reasons.

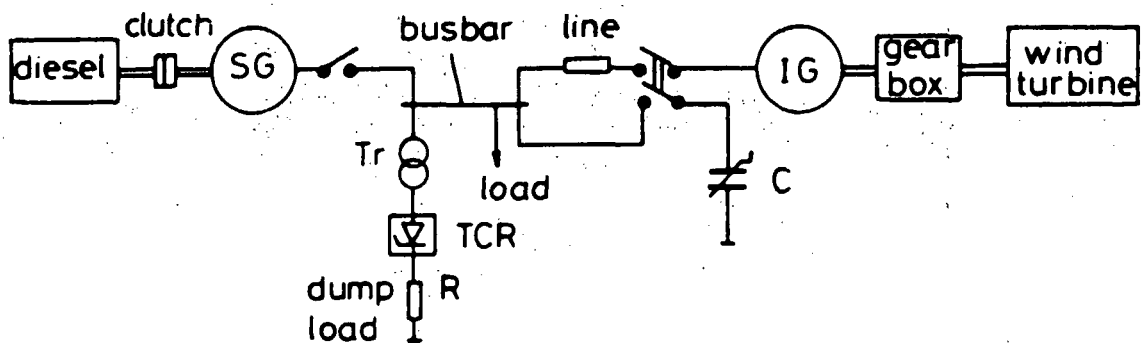

Figure 13 Diesel-wind system with induction generator [Tsitsovits and Freris, 1983].

Modelling of the experimental system, in which the wind turbine is equipped with a synchronous generator, showed sensitivity to wind speed variations on a time scale of 2 seconds, and frequent diesel starts as a consequence (Figure 14). It would seem simple to build in a bit more inertia into the system, to avoid this problem. Simulations including storage brings out the rapid decline in diesel starts/stops as function of storage capacity (Figure 15).

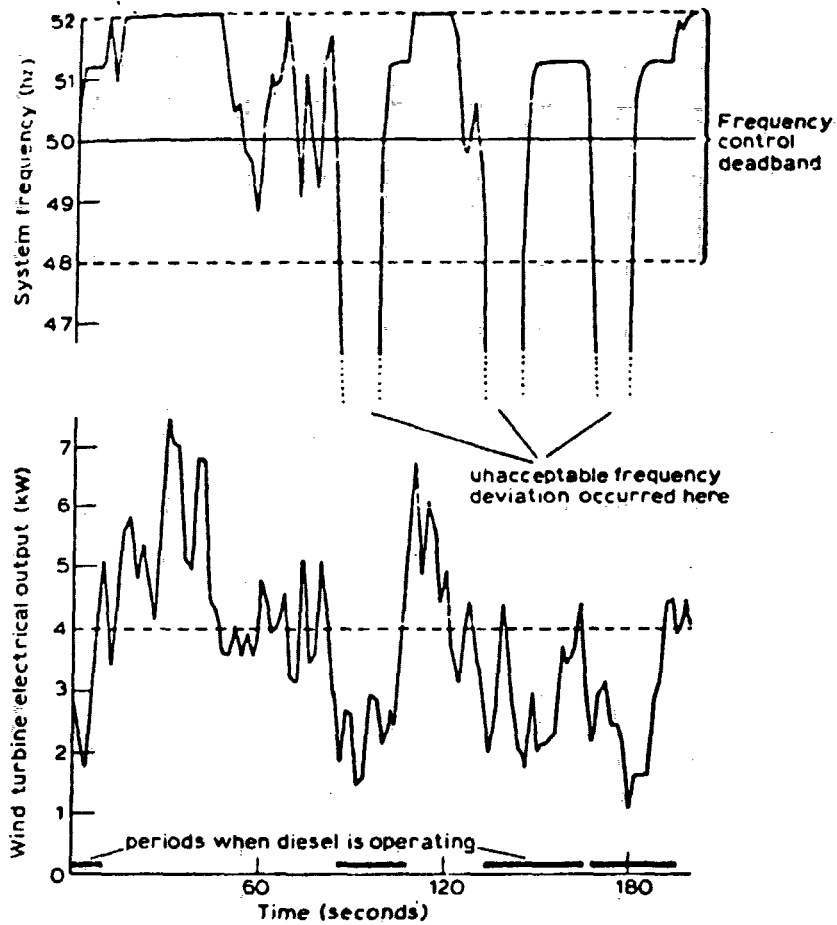

Figure 14. Model output for wind diesel operation in worst case situation of wind speed near wind turbine cut-in speed.
 (top to bottom: frequency, wind power, diesel on/off)
 [Lipman, 1984]

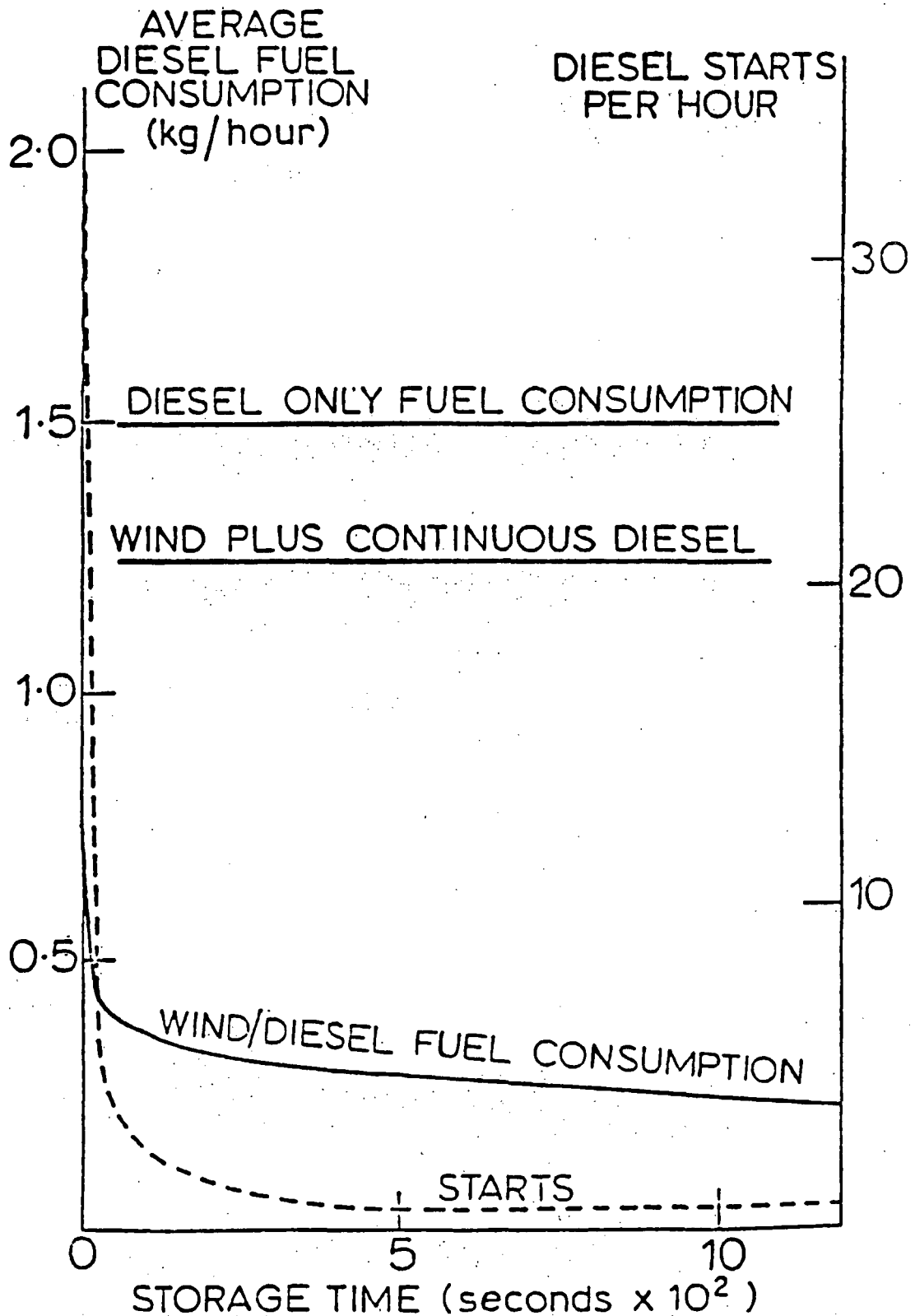

Figure 15. Calculated fuel savings for different modes of operation of wind-diesel system (diesel alone, diesel always on, intermittent diesel), plus number of starts in the latter mode [Lipman, 1985]

An alternative would be to have two diesel sets of which the smaller one is operated continuously and the larger one intermittently. Simulation of this system is shown in Figure 16, using 1 minute averaged wind data (see also Section 2.2).

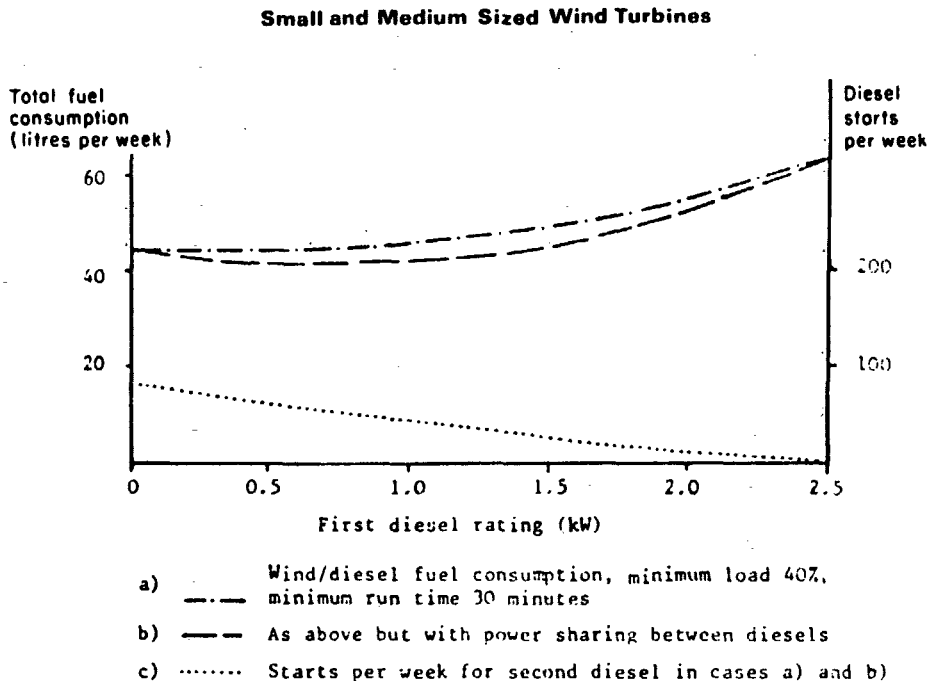

Figure 16. Total fuel consumption and number of starts per week for the larger diesel, as function of the percentage rating of the smaller diesel [Lipman, 1984]

The model calculations discussed above are based on several assumptions that may not be relevant in practice. The finding of diesel upstarts averaging about one per minute appears unrealistic and avoidable by simple modifications of control strategy. This view is supported by the experimental findings, and by the practical experience reported in Section 2.1.1. It is true, that the systems studied in the Rutherford/Imperial College/Hawker-Siddeley project aim at precisely the situation, where larger controllable loads and stores are not available, in contrast to the Lundy and Fair Isle cases, but this should not make rapid on/off cycling of the diesel sets necessary - but should rather show up in terms of a higher fraction of wind-produced energy being dumped.

2.1.3 Energy Research Center (The Netherlands)

Two wind-diesel experiments are in progress at the ECN (Energieonderzoek Centrum Nederland) in Petten. The simpler one called the "verification system" is illustrated in Figure 17.

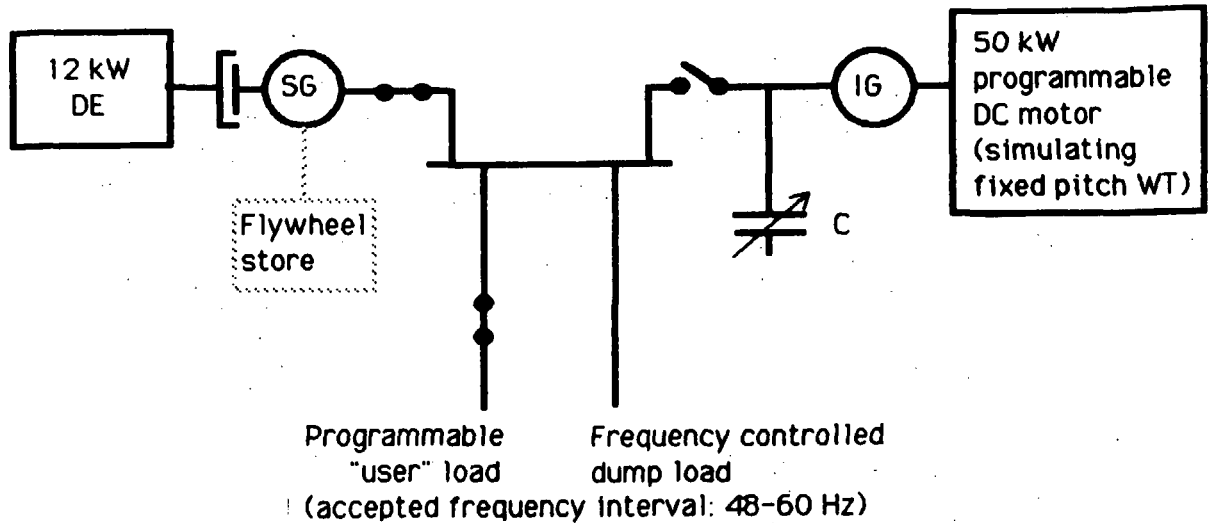

Figure 17. ECN verification system
[Bonte et al, 1985].
Abbreviation: IG = induction generator

In the "verification system", the accepted frequency fluctuations are very high (48-60Hz), and the wind turbine is replaced by a programmable DC-motor, which is used to simulate the inputs from different types of wind generators. Much of the experimental work on this setup has been to learn the behaviour of the diesel engine. Figures 18 and 19 show the measured fuel consumption as function of loading, and the extra cold start fuel expenditure, as function of the load step. Cycling the load is found to affect the fuel consumption by less than 8%, even for cycling (0.1Hz) around very light loads.

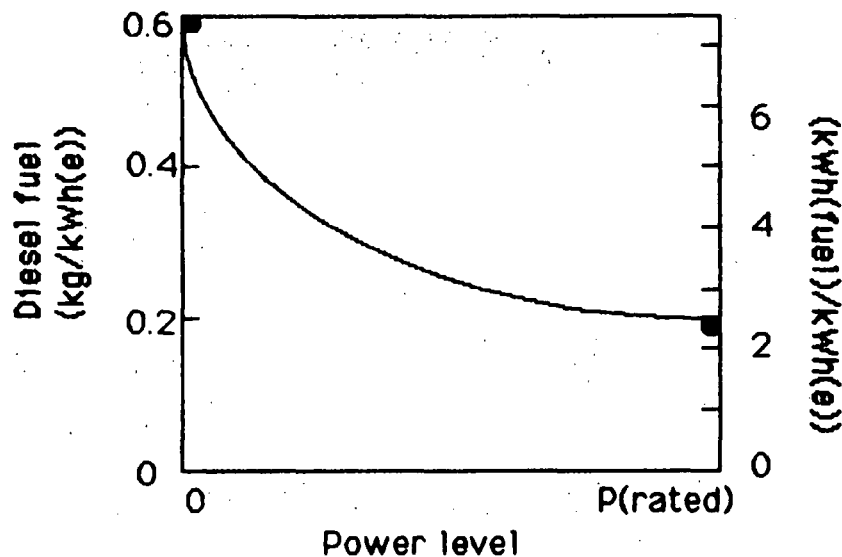

Figure 18. Measured diesel fuel consumption

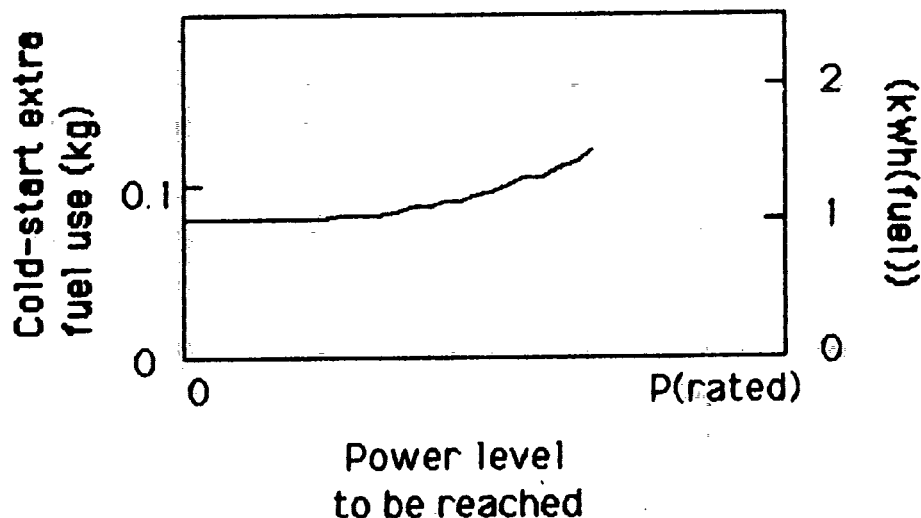

Figure 19. Measured cold start extra fuel consumption

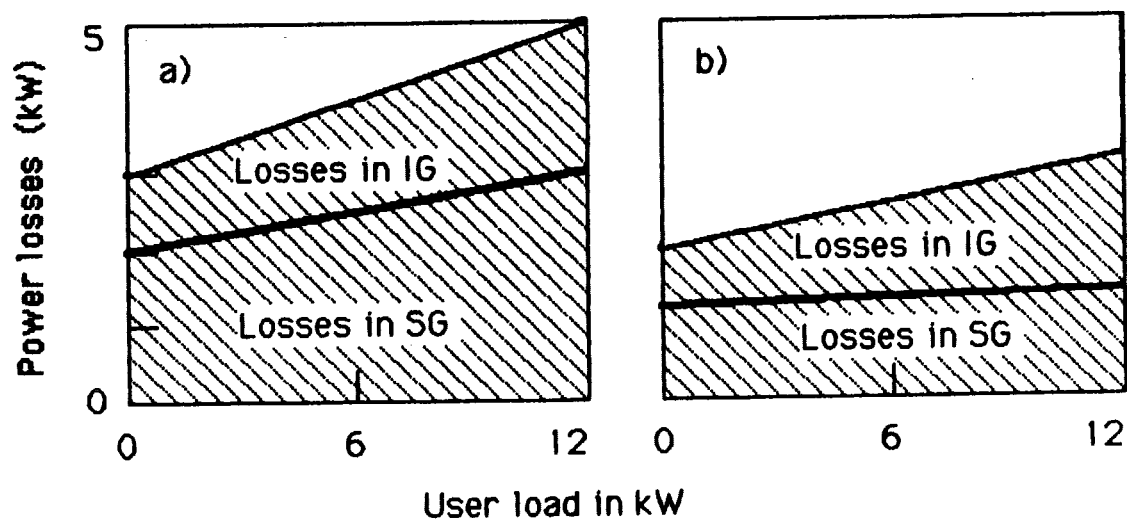

Figure 20. Measured losses in "verification system" operated with diesel engine disconnected.
 a: No reactive power compensation,
 b: With reactive power compensation.

Figure 20 shows the importance of the reactive power compensation achieved by means of the variable condenser, for minimising generator losses. The synchronous generator is running continuously.

The second phase of the Dutch experiments is operation of the "test site system" illustrated in Figure 21. Two wind turbines are installed, as this is believed to smooth out gust amplitudes. Both have variable pitch angle control. Power conditioning is by rectifier plus inverter steps. The

grid frequency is not controlled by pitch variation but by dump load management, when there is a power surplus, and by the diesel controller when the engine is on line. An additional controller handles possible mismatch when changing over between the two frequency handling methods. It is planned to replace the power dump by battery storage sometime during 1986.

From [Bonte et al, 1985] it appears that the criteria for disconnecting the diesel engine are:

1. That during the last 10 minute period;
Minimum instantaneous windpower $> k \times$ (maximum instantaneous load plus losses), where k is chosen to be about 2.5 for the actual installation, 3.0 for a single variable pitch wind turbine and up to about 5.0 for fixed pitch machines (see Figure 44). Gusting characteristics may differ from site to site. The numbers quoted pertain to wind turbine operating below full load.
2. Minimum diesel operating time is 10 minutes.

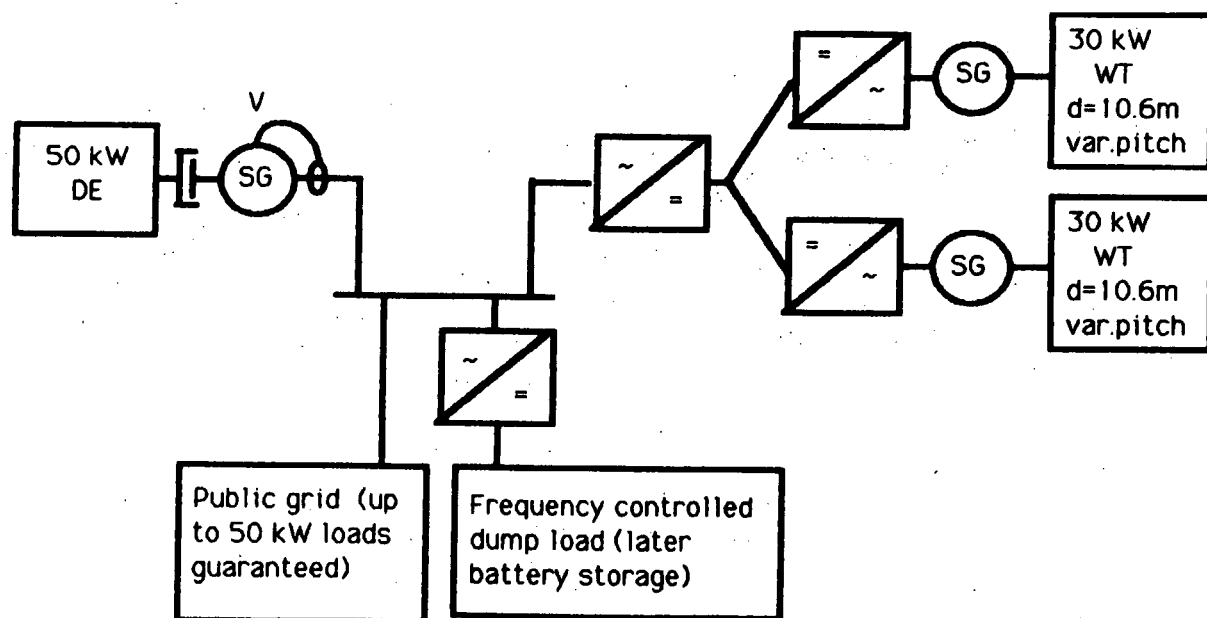

Figure 21. ECN test site system
[Bonte et al, 1985]

Figure 22 shows the output of a measurement run, in terms of 1 minute averages of samples taken every second. The number of diesel starts corresponds to 16 in 24 hours.

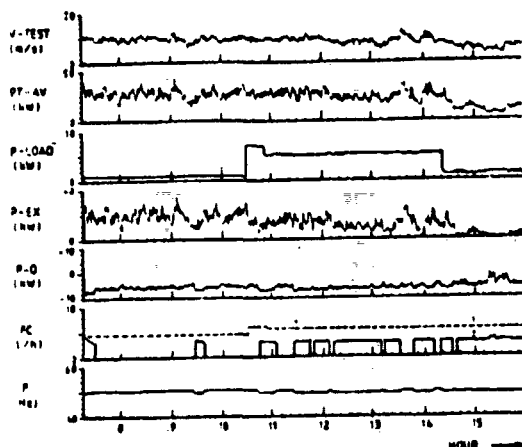

Figure 22. Measured 1 min averages at test site system, for 8 hours. From top down are shown wind speed (V), wind produced power (P_W), load (P_L), dumped power (P_{EX}), power from diesel synchronous generator (P_D), fuel consumption (FC) with (full line) and without (dashed line) wind contribution, and finally the grid frequency (f).

The average net power from the diesel S.G. is negative, indicating that the wind turbines are turning the generator more often than is the diesel.

More comprehensive results of 218 hours of measurements give the results summarised in Figure 23. The diesel engine was operating 94% of the time. Fuel use was 53% below what it would have been (Figure 24) without wind.

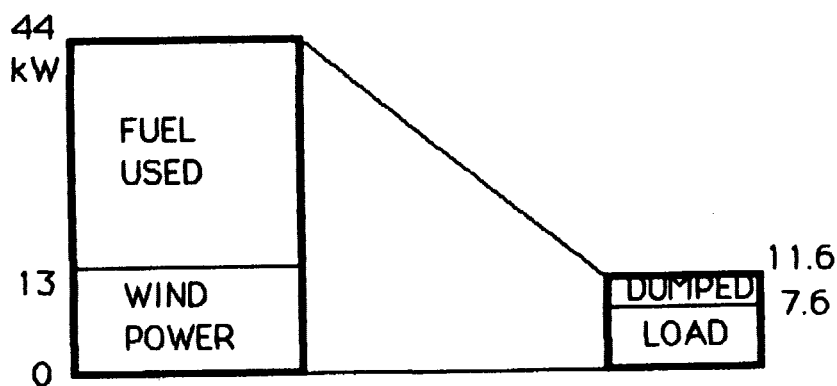

Figure 23. Measured energy input flows and disposition for 218 hour period.

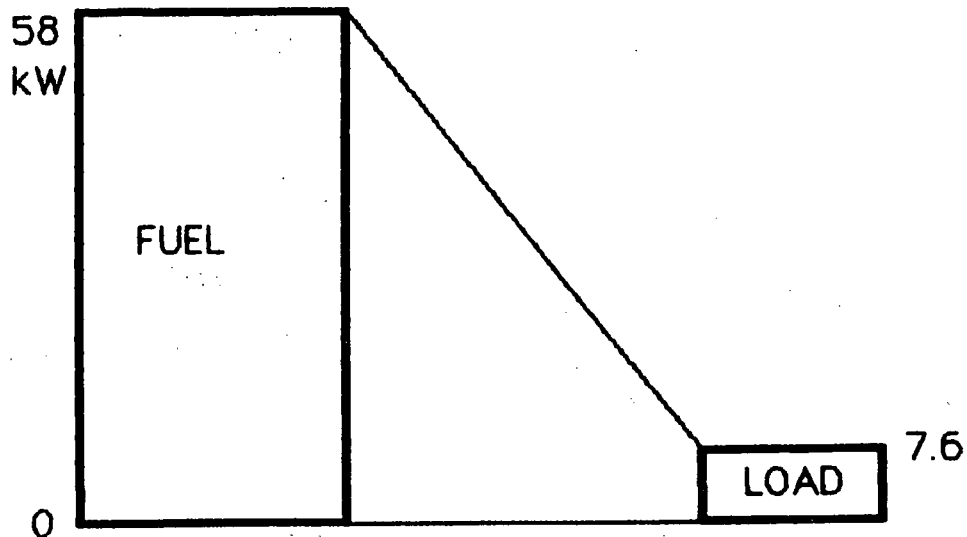

Figure 24. Inferred energy flow for pure diesel system, for the same case as Figure 23.

The fuel use in the absence of the wind components corresponds to 7.7kWh (fuel) per kWh(e), implying that the average load on the diesel would have been 20% (derived from Figure 18). Due to the combination with wind, the actual average diesel loading has been even lower. It appears that the light loading wear problems anticipated by the British group are not believed to be serious in Holland. However, there are wear measurements in progress, using the neutron activation facility at ECN.

The saving of 2.7 litres per hour of fuel (relative to 5.8) and dump of 30% of the wind produced power (making use of 70%), would seem an encouraging result, considering that user loads are not controlled and that there is no heat storage in the system. However, the initial test conditions are somewhat peculiar, in that the average load is very low relative to the diesel rating (7.6 vs. 50kW) whereas the average power production of 13kW for the twin wind generators (rated at 60kW) is closer to the average load. This means that the diesel fuel consumption, to which savings are compared, are about twice what they would have been for a diesel rating more suited to the load (say 15kW). Further experiments at higher loads will be able to tell about the performance of this type of system in more realistic applications.

The Dutch group has developed computer simulation programs in order to study transient phenomena on a 1 sec. scale. The programs give reasonable agreement with measurements performed on the verification system (where "wind" input can be made to exactly match model assumptions). One reason for supplementing experiments with simulation models is the need for predicting the performance of proposed wind-diesel systems to be operated under wind and load conditions different from those at the test site.

2.1.4 Jutland and Riso (Denmark)

Jutland Telephone Co. Hybrid System

The system depicted in Figure 25 and shown in Figures 26-27 has been operating since 1985.

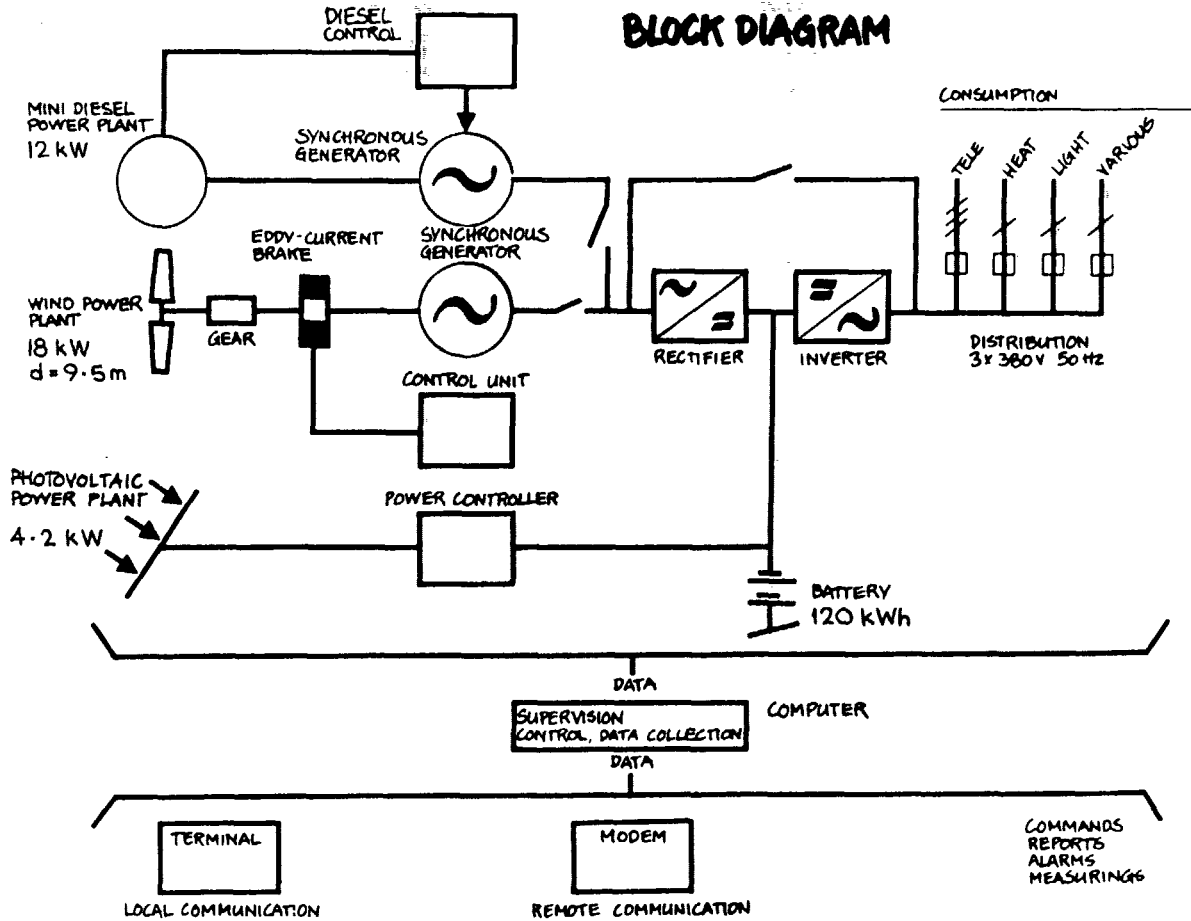

Figure 25. Wind/PV/diesel system of Jutland Telephone Co.

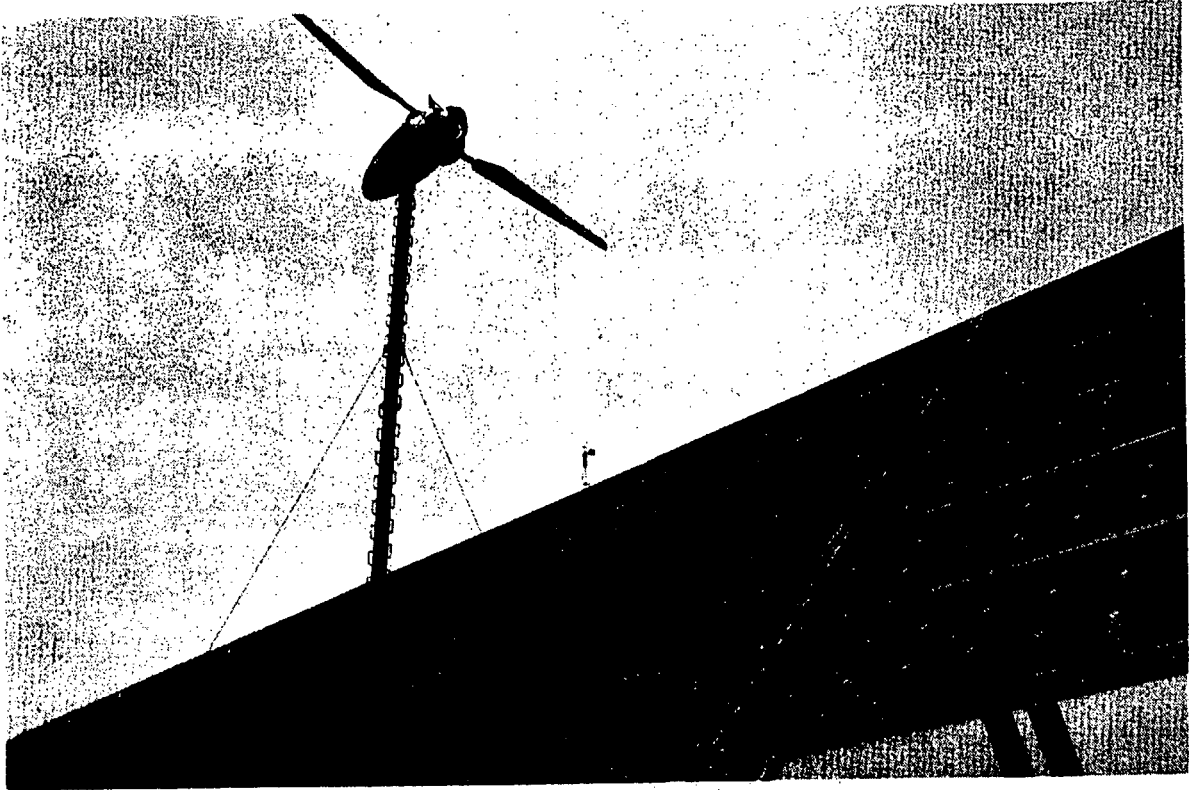

Figure 26. Wind turbine and photovoltaic array at Olst, Jutland.

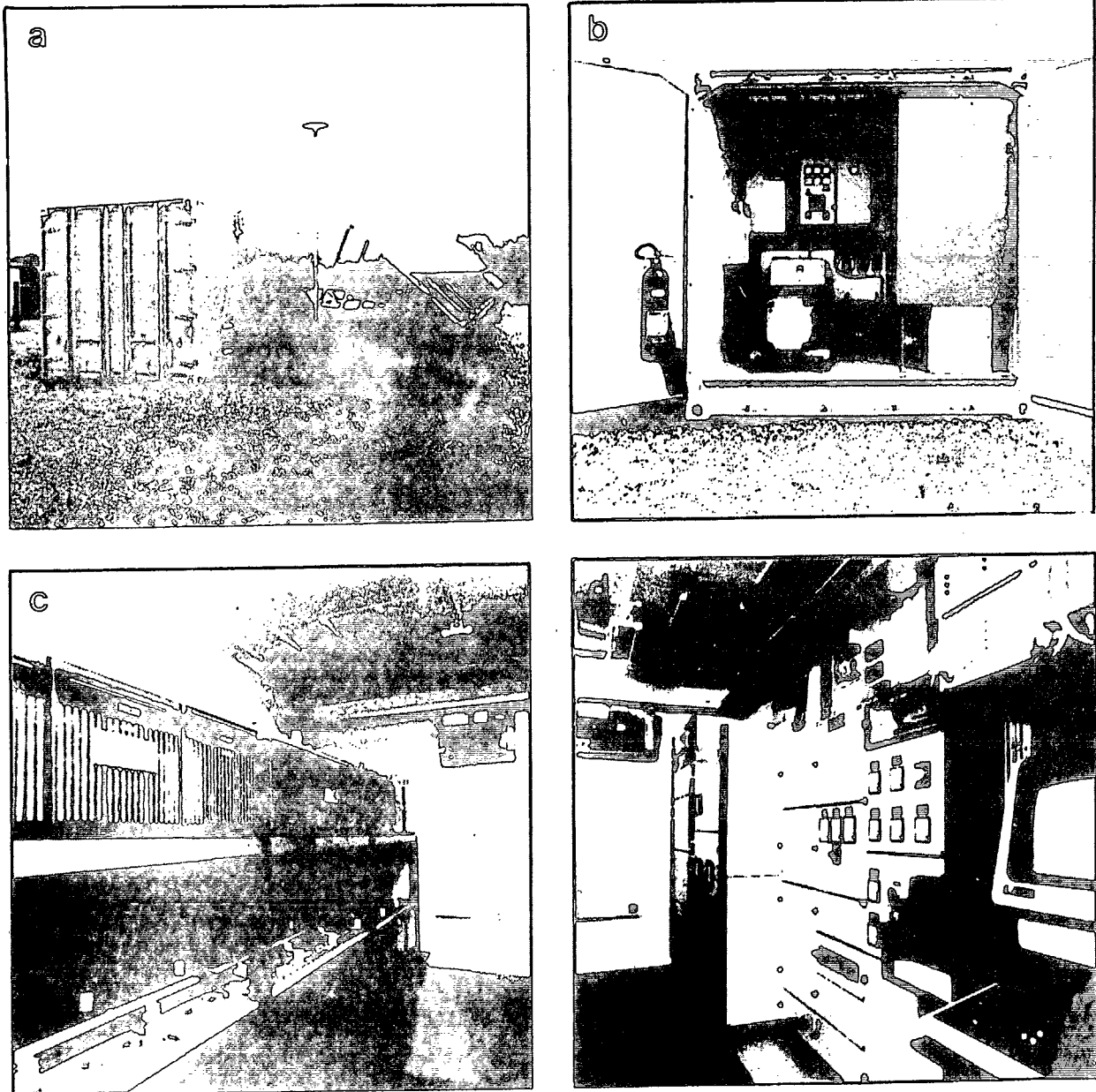

Figure 27. Container (a) for diesel set (b),
battery store (c) and controls (d)

The 12kW diesel engine has an extra large oil sump, antimony free lead-acid batteries are used, and the 18kW wind turbine is equipped with a 30kW eddy-current brake, which is used for power control instead of an energy dump. This novel feature has been tested since 1978 on another Jutland Telephone wind turbine (no solar or diesel), located at Nees and serving telephone exchanges in the area.

The Olst system has operated satisfactorily in general terms - a detailed report on operating experience is expected by March 1986 [Power Section, JTC].

Riso National Laboratory

The Wind Turbine Test Center at Riso is involved in two wind-diesel experiments, aimed at the establishment of a permanent test facility for manufacturer's wind-diesel systems, similar to the existing one for wind systems.

The first system, called a "state of the art" system, is illustrated in Figure 28. It started operation in 1985. Its design principle is to use a standard wind turbine without pitch control and with an induction generator, and further to let the wind turbine controls be self contained and not linked to the system control. In this way, it would be easy to add wind generators anywhere on the local grid of a real system.

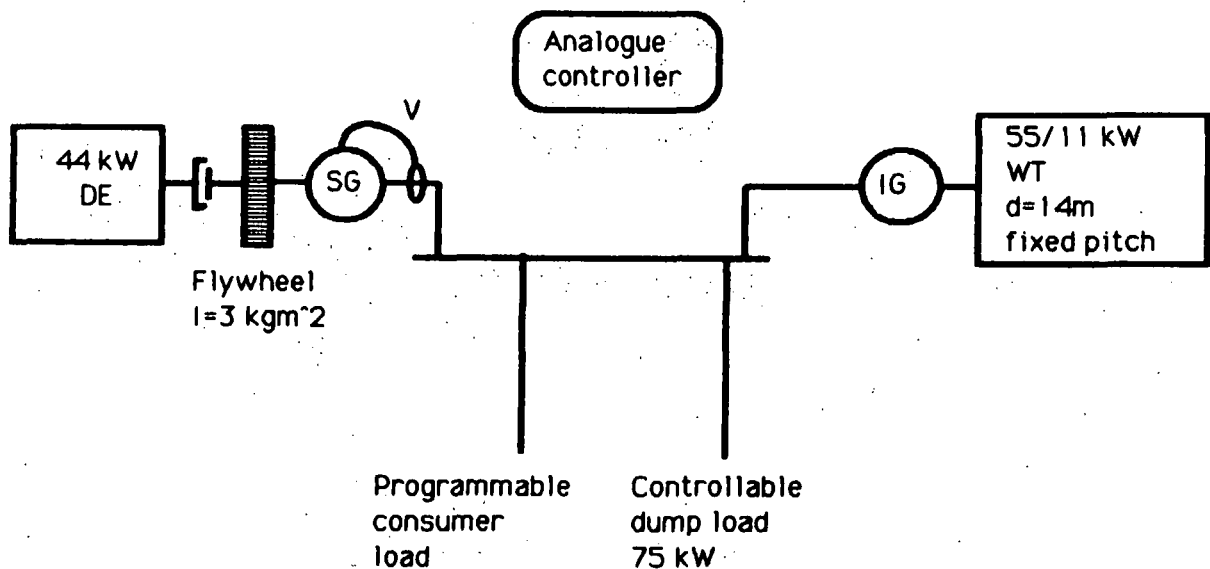

Figure 28. Riso "state of the art" system.

The system is thyristor controlled by a dump load. One unusual component is the flywheel inserted between the diesel clutch and the synchronous generator. It was meant to speed up diesel start (1 sec was predicted by Lundsager and Madsen [1985]), but measured values of 2.4 sec are not significantly better than with electric starter motors (≈ 3 sec). [Madsen and Lundsager, 1985]. The flywheel may help a bit in maintaining frequency, but it is too small to serve as energy store during diesel upstarts.

Other tests so far have been to measure diesel sensitivity to cycling and sudden application of real or reactive loads.

The second system, expected to be operational during 1986, is shown in Figure 29. It is developed in collaboration with Chalmers Technical University in Sweden. Its wind turbine (derated to 22 from 55kW) is equipped with independent speed and voltage controls. The battery may be charged from either diesel or wind side.

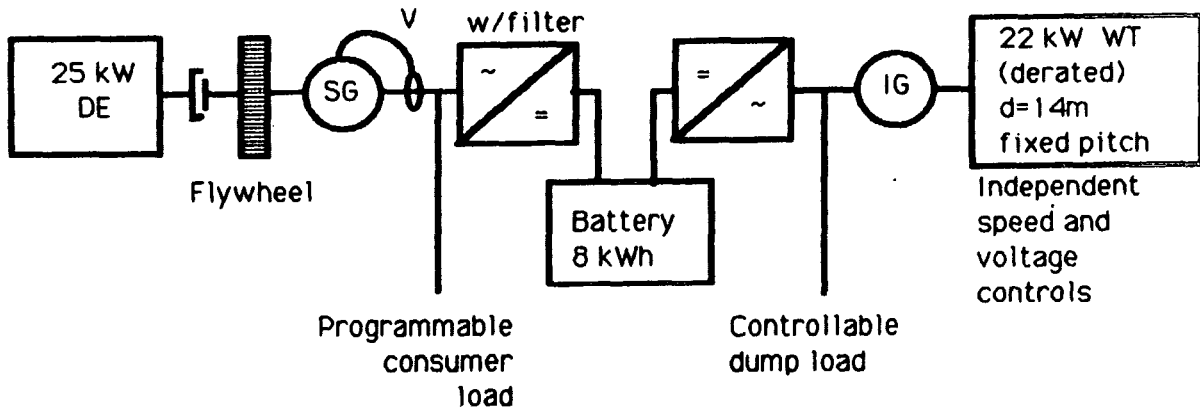

Figure 29. Riso/Chalmers "advanced system"

The Riso Test Station notes that due to extended frequency ranges for wind-diesel application, one should check that none of the eigen-frequencies of the wind turbine/tower construction lie within this increased range.

2.1.5 Kythnos (Greece)

The Kythnos installation (Figure 30) is described by the Greek Power Corporation as "grid connected wind generators" rather than a "wind-diesel system". Load variations are huge (presumably due to tourism), so although wind provides only 14% of the average load, it might provide 100% if high winds occur at the time of minimum load. Operation details have not yet been published, but with an annual wind power production of 170MWh [communication from G Karamanzanis, Public Power Corporation], and a reported fuel saving during the first year of 30t or 12.5% [Tsitsovitis and Freris, 1985], it would seem that the system has performed satisfactorily.

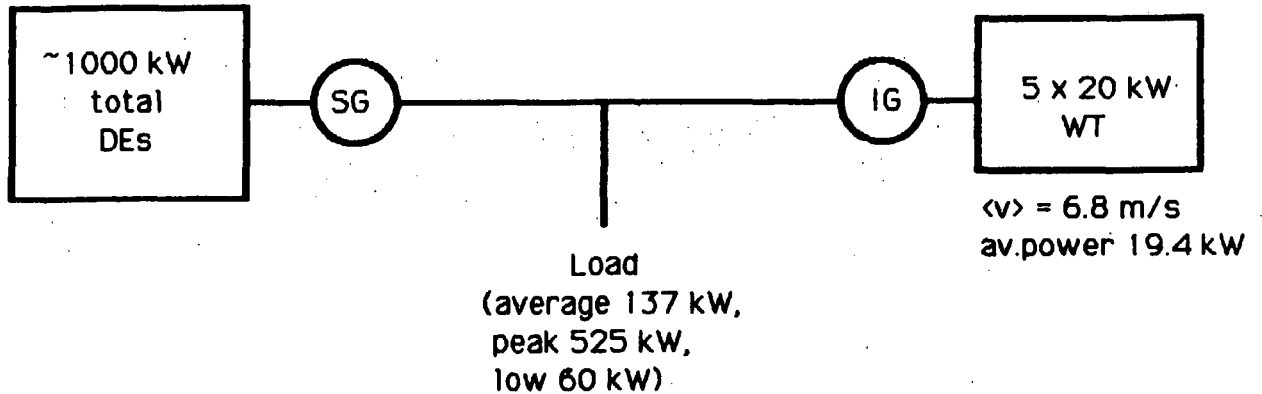

Figure 30. Kythnos wind-diesel system.

2.1.6 Tristan da Cunha (Atlantic Ocean)

With UK assistance, a 45kW wind turbine with induction generator was attached to the diesel-powered grid. Minimum load was similar to maximum wind power output, so a controlled dump was also installed. The wind generator failed during a storm, after about a year of operation [Garside, 1982].

2.1.7 Fernando de Noronha (Brazil)

With West-German assistance, it is planned to integrate wind and possibly solar power into the island diesel system of Fernando de Noronha. Average wind speed is (6.9 ± 0.7) m/s (based on 4 years of measurement), with a seasonal dip in April-May. The present maximum load is 200kW, with an average load below 100kW. There are 1300 inhabitants on the island. A surprising 60% of daily peak load is believed to be mainly associated with grid losses.

As part of the design process, a German-Brazilian test field has been established in Natal on the mainland. Its layout is shown in Fig. 31. It is to be frequency controlled, with schemes such as the one shown in Figure 32 [Schott and Reiniger, 1984]. I have not found any published results from the test programme.

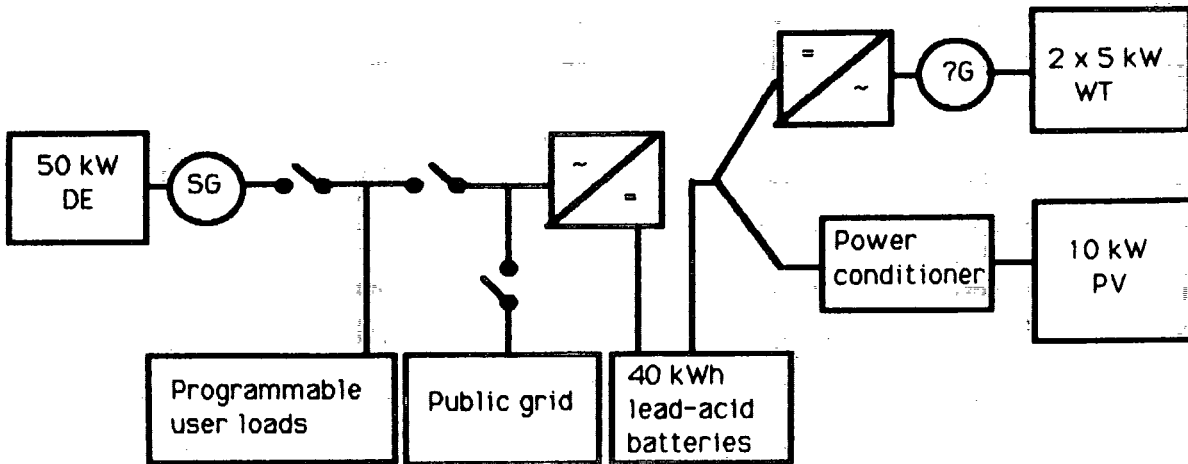

Figure 31. Natal test field installation. The renewable energy part may be operated with the public grid or with a programmable, "weak" grid, with or without diesel backup.

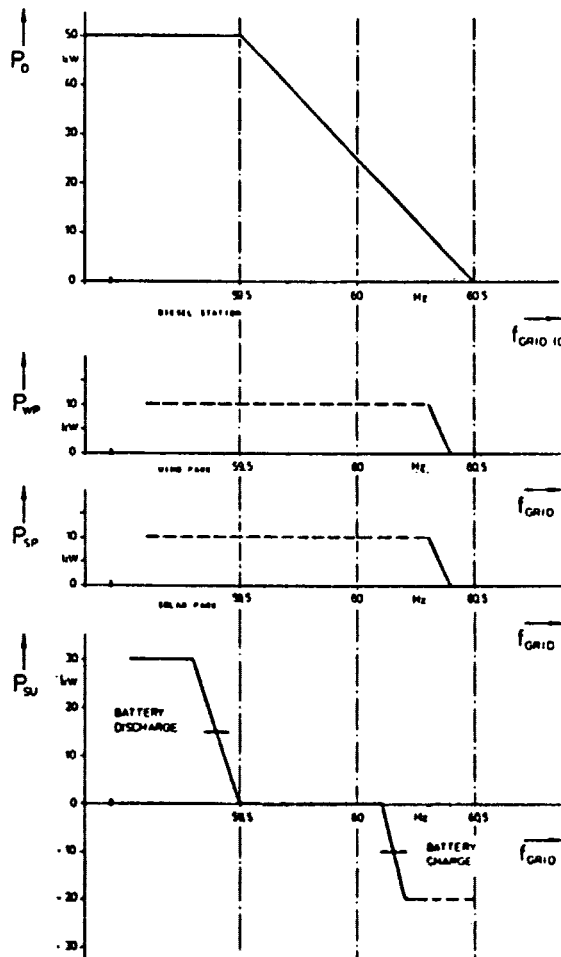

Figure 32. Frequency based control scheme.

2.1.8 Martigny (Switzerland)

A 150kW wind-biogas plant is being built at Martigny (Figures 33 and 34).

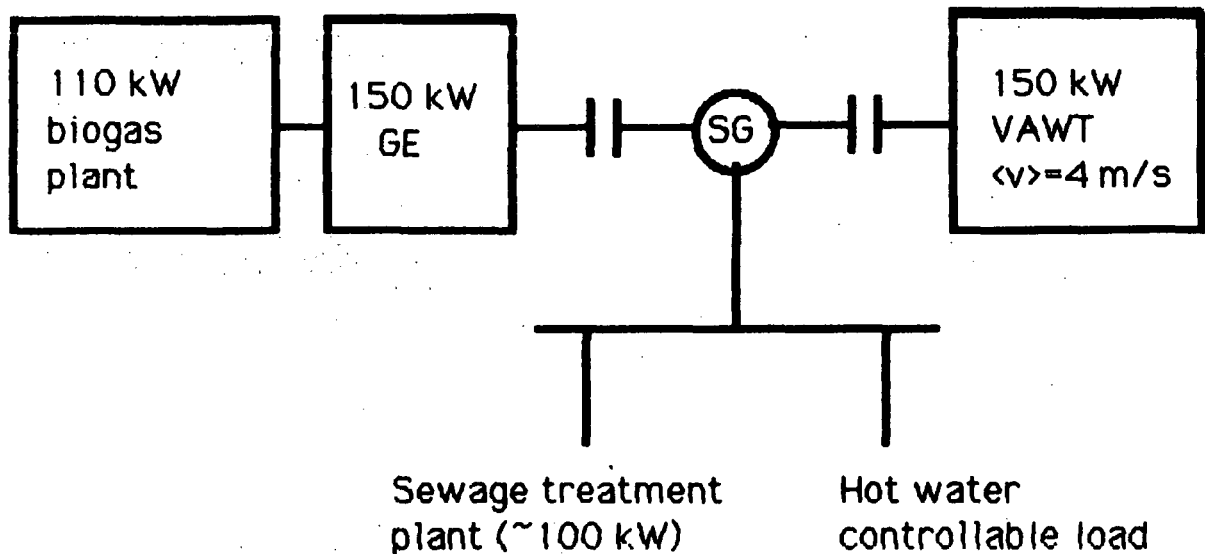

Figure 33. Martigny wind biogas system.

Abbreviations: GE = Gas engine, VAWT = Vertical axis wind turbine.

The combination of biogas production and use with sewage treatment is common in Europe. The addition of a wind generator in this case seems ill advised, due to the very low average windspeed. However, it is claimed that there is a steady occurrence of windspeeds at or above 8m/s for 3 hours a day during Summer, due to the mountain valley wind phenomenon. Small wind-diesel sets (around 2kW) have been operating at Swiss mountain sites for over 30 years [communication from L Dubal, Federal Office of Energy].

2.1.9 Other European projects

A few other wind-diesel installations are being operated in Europe, mostly by private owners from whom data are difficult to obtain. A 100kW system is operated on Quessant Island, France. In the U.K., a scheme with direct hydraulic coupling between wind turbine, diesel engine and electric generator is being investigated [Lawson-Tancred, 1982]. Both wind turbine and diesel speeds are variable; there is no gear box, but a small compressed fluid store (10 seconds) will be able to start the diesel engine after sudden drops in wind energy. A 40kW wind-diesel project is in progress on Shetland Island.



Figure 34. Martigny installation.

Several more island wind-diesel systems are planned or being installed in Greece (totalling 655kW), two in Italy (100 + 200kW), and the installation of a 75kW wind generator with the existing diesel system (about 250kW) on the Danish Island Anholt has been decided.

The International Energy Agency conducts a wind-diesel programme, headed by Dr G Elliott of the National Engineering Laboratory in Glasgow, presumably with the intent of publishing another pamphlet in the agency's series on "Recommended Practices".

2.2 North American Experience

No extensive search for literature on North American wind-diesel systems was made, so the following should be taken as an indication only.

2.2.1 United States

The first medium size wind diesel system in the US was operated on Cuttyhunk Island (MA) from 1977 until a wind turbine failure. The 200kW wind turbine (rotor diameter 24.4m) with synchronous generator was coupled to a grid fed by 6 diesel sets from 30 to 175kW (rated). A controlled dump load was used because minimum load was below 200kW.

During 1980-82, a 150kW (derated) MODOA wind turbine was operated on Block Island (RI), chiefly in conjunction with two diesel sets as shown in Figure 35, but with several other diesel engines in reserve. The average load was 350kW, but with large variations due to Summer tourism. The fuel characteristics of the 225kW (#8), 400kW(#9) and a larger 500kW (#10 unit), which was brought on line when large loads were expected, are given in Figure 36.

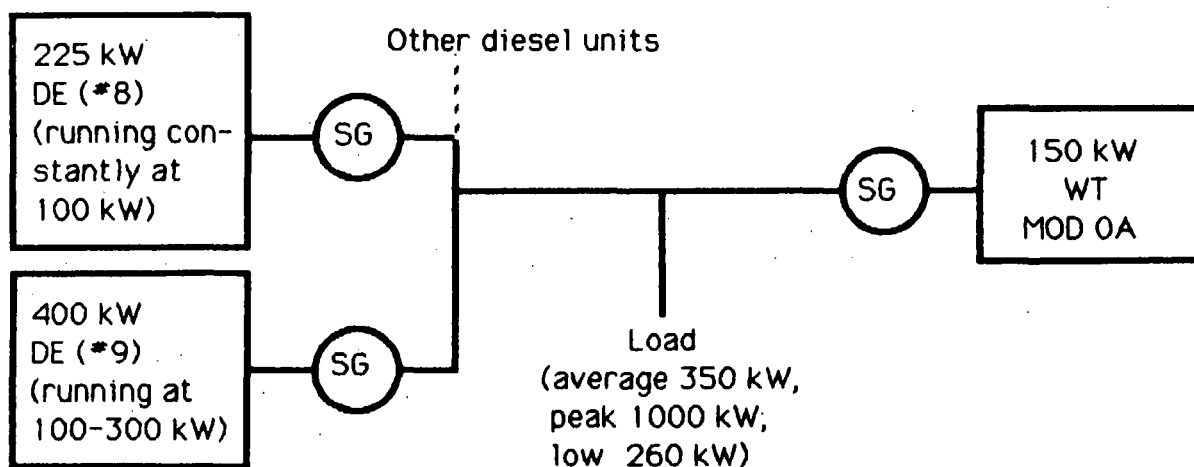
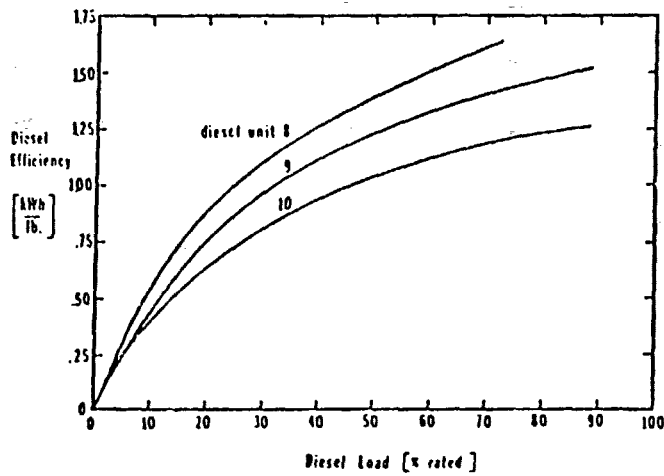
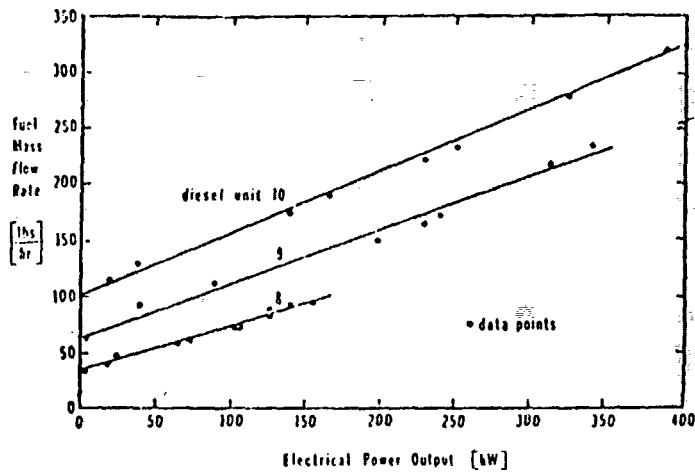

Figure 35. Block Island wind-diesel system.
[Stiller et al, 1983].



Diesel Unit Incremental Rates

<u>Unit #</u>	<u>Incremental Rate</u>
8	0.43 lb fuel/kWhr
9	0.49 lb fuel/kWhr
10	0.57 lb fuel/kWhr

Figure 36. Measured fuel use, efficiency and fuel use slope for 3 diesel engine sizes.

The parallel operation of wind and diesel takes the form illustrated in Figure 37. Diesel unit #8 is operated at 100kW constantly, and unit #9 is governed according to wind power contribution. Light load operation (25% of rated power) does not seem to present any problem.

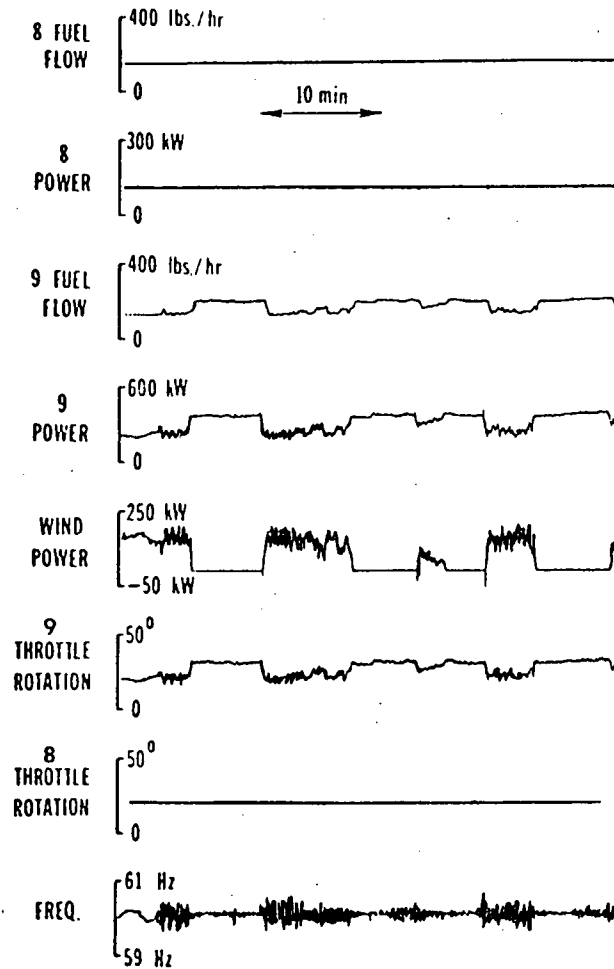
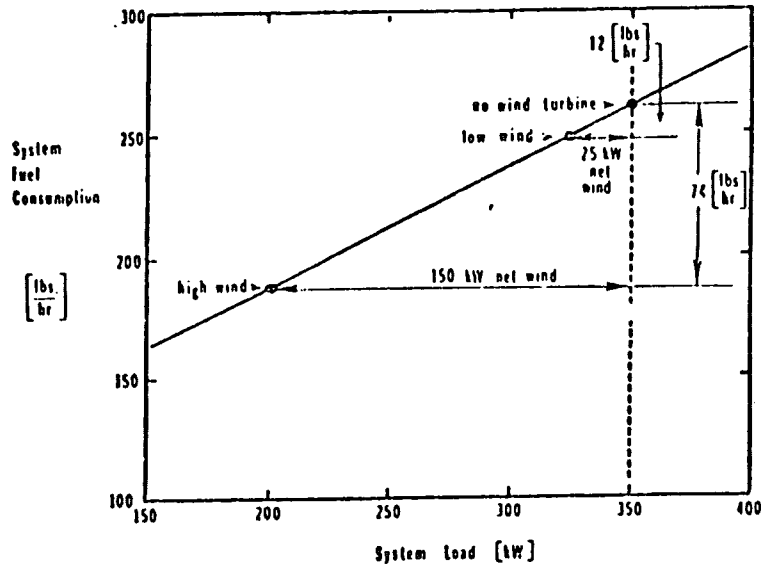

Figure 37. 45 minutes of data recorded.

The fuel displacement results are illustrated in Figure 38, with indication of the two cases of full wind power production (150kW) and a low wind 25kW output. The deduced fuel saving is 6.7%, while the wind turbine displaced 11% of the energy load [Stiller, et al, 1983]. The difference is due to auxiliary electric power consumed by the wind generator, and the decreased efficiency of the diesel operation.

A similar installation (200kW MODOA wind generator) has been operated in Clayton (Ohio), in conjunction with a very large (6400kW rated) diesel powered system.

Small wind-diesel installations are operated in Alaska, and a large (7 x 250kW) wind park is planned for the St Pauls Island diesel system.



Fuel Displacement Results for Test Period*

1)	diesel unit (unit #9) incremental fuel consumption*	0.49 lbs. fuel/kWh
2)	gross MOD-OA wind turbine energy	56,900 kWh
3)	MOD-OA wind turbine auxiliary energy	4,470 kWh
4)	displaced fuel (line 2 - line 3) x line 1	25,700 lbs. (3,560 gal)
5)	gross energy generated (diesel and wind turbine)	496,000 kWh
6)	total fuel burned	358,000 lbs. (49,800 gal)

*Table is based on unit #9 incremental fuel consumption because this unit was used for load frequency control during the test period.

Figure 38. Fuel displacement.

2.2.2 Canada

A directly connected 30kW horizontal axis wind turbine and 2 x 46kW diesel engines (Figure 39) has been operated since 1981 at Sudbury (Ont.). One diesel engine operates continuously, with minimum load 20% of rated, the other diesel unit on an on/off basis. Overproduction is taken care of by a dump load. Measured fuel savings are shown in Figure 40. During 3353 hours of operation, forced outage was 10.5% (diesel trouble) [Templin and Rangi, 1983]. 9% of the load was supplied by wind, during a period with average wind speed 5.4m/s.

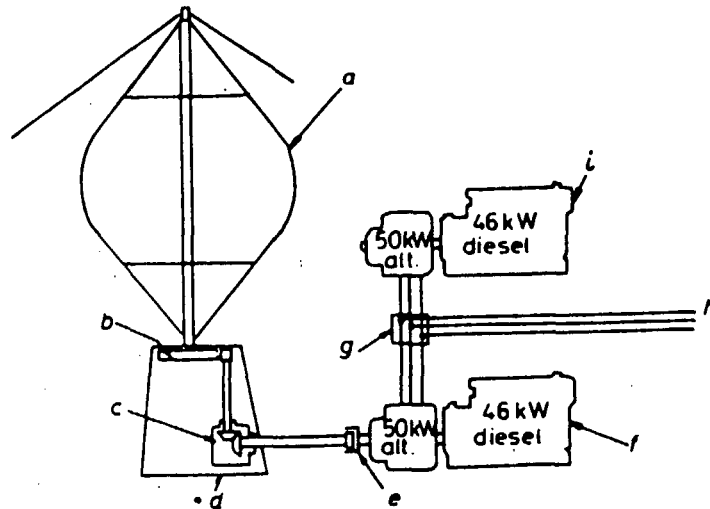

- a DAF Indal 16.8 m x 11.2 m VAWT, rotor speed = 71.4 rev min
- b Primary speed increaser, ratio = 14:1
- c Right-angle gearbox, ratio 1.2:1
- d Power module (pedestal)
- e Cam clutch
- f Primary diesel generator unit
- g Autosynchroniser
- h 3-phase power to system load and dump load banks, 600 V, 60 Hz
- i Secondary diesel generator unit

Figure 39. Wind-assisted diesel system at Sudbury.

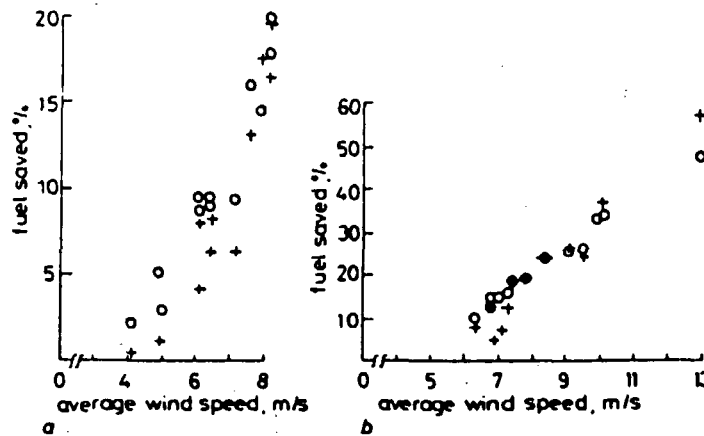

Figure 40. Sudbury wind-diesel fuel savings (circles: predicted, crosses: measured, a: both diesels operating, b: second diesel off)

Continued experiments with a 50kW wind turbine suggests higher fuel savings, may be of the order of 30-40%. [Chappell and Templin, 1985]. Diesel fuel costs between 8 Can ¢/kWh and over 1 Can \$/kWh are typical of remote areas in Arctic Canada, but wind turbine installation costs in these regions are also expected to be high.

2.3 Australian Experience

Australian experience with wind-diesel combinations are discussed in Crawford [1984 and 1985] and will not be repeated here except for presenting the layout of the installation on Rottneest Island (Figure 4.1). Mini-size systems are discussed by Langworthy [1985], and the Lord Howe Island proposal by Barker et al [1983] and by Outhred and Harrington [1985].

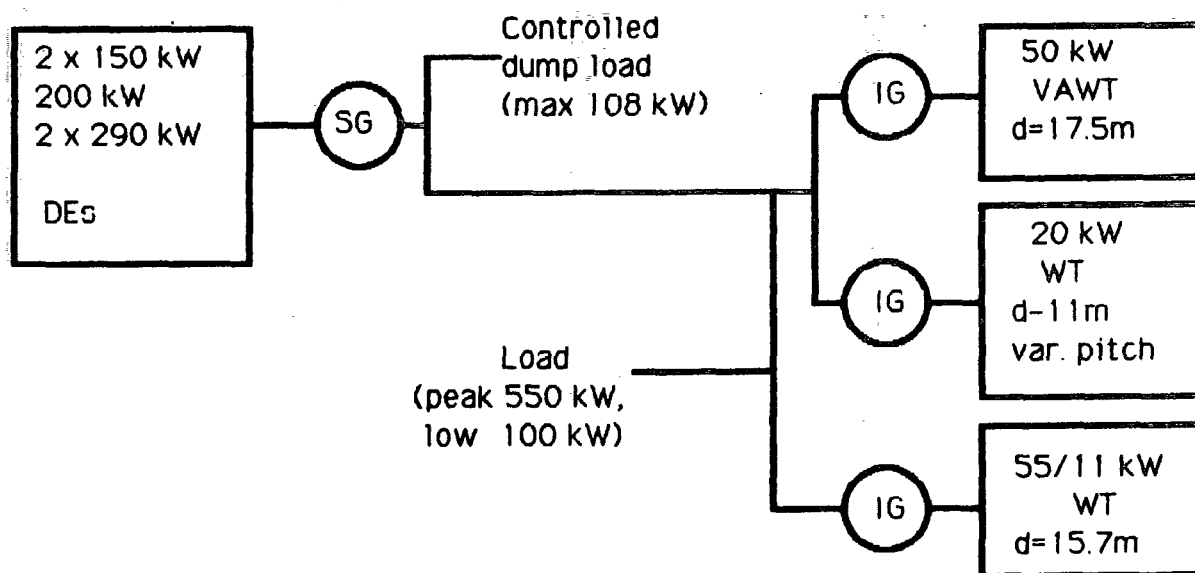

Figure 41. Rottneest Island system.

During a 24 hour period in which the wind generated power averaged 35.3% of the Rottneest system load, the diesel plant is reported to have been "oiling up" due to light loading making the operator fear cylinder damage and since then hesitate to bring the wind turbines on line. As the diesel ratings in Figure 41 indicate, it would have been no problem to select a combination of units that would have operated near optimum loading. Thus a proper evaluation of the wind-diesel system would in this case seem to require automatic dispatch of diesel units in a wind power maximising strategy.

3. CONFIGURATION CONSIDERATIONS AND OPERATIONAL STRATEGIES RELEVANT FOR NSW APPLICATIONS

The small community power systems aimed at with the wind-diesel combinations considered in this report would be characterised by average consumer loads in the broad range of 20-500 kW. Minisystems for individual household use (1-20 kW) will not be dealt with.

Generally, the choice of configuration is determined by the characteristics of load and of the wind resource, as indicated in Figure 42. Externally given quantities usually comprise wind regime classification (average windspeed, frequency distribution, height dependence, hourly and seasonal dependence, lull durations, etc) as well as load specification (average, maximum, minimum as well as detailed temporal distributions). It is very important for systems incorporating wind contributions, whether all loads are time-urgent (ie have to be satisfied at particular times), or if some may be displaced in time, to a smaller or larger degree. In the following, all loads will be considered time-urgent, but in the discussion, the implications of some loads being deferrable will be mentioned.

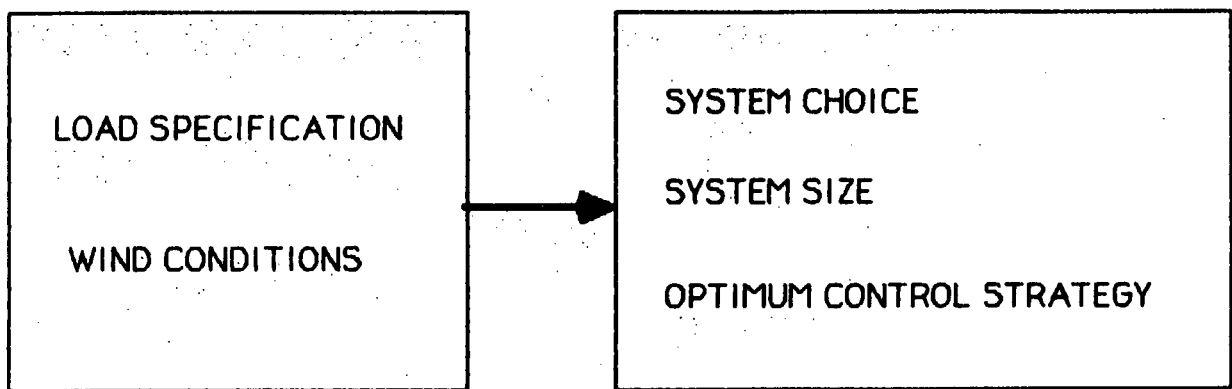

Figure 42. System Considerations

Given load and wind characteristics, an optimisation may be attempted as regards system configuration, system size and operating strategy. The optimisation may be made in physical terms (such as minimising fuel use) or in economic terms (typically by minimising direct costs). There may not be any physical optimum, because fuel use can in principle be reduced to zero, by installing a sufficient number of wind generators and adding energy storage facilities to cope with any occurring period of insufficient wind. At present, the cost of such a system would be prohibitive, so the approach taken here will be to estimate the cost of any system component which is contemplated, and to discuss the optimisation procedure in purely economic terms (although interesting quantities such as fuel saving will of course be calculated and presented).

In order to exhibit more clearly the considerations involved in the system configuration choice, a slightly less aggregated version of Figure 42 is given in Figure 43.

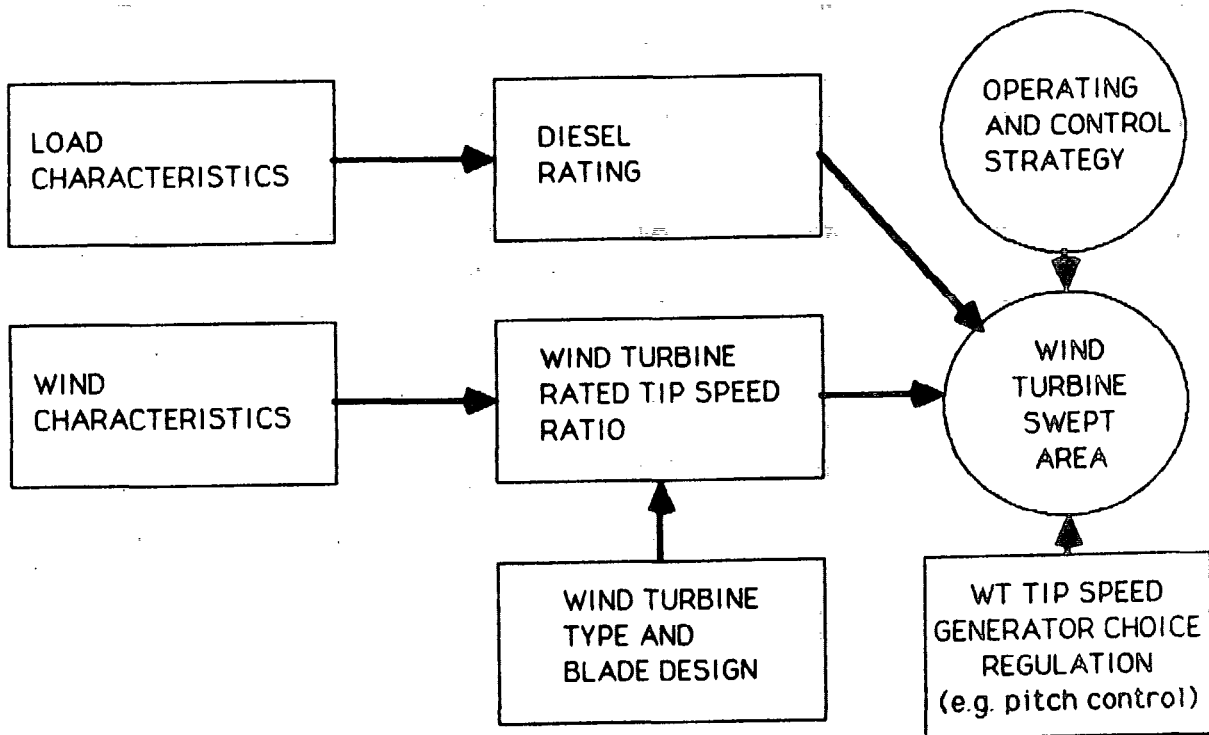

Figure 43. System choice. The quantities encircled are the variables primarily to be varied in the process of economic optimisation. (The tip speed ratio is the ratio between blade tip speed and wind speed).

Since no complete storage back-up facility is considered, the (total if more than one) diesel generator rated power level simply has to be chosen as the maximum load plus some safety factor to account for load fluctuations and to some extent for possible load growth.

The wind characteristics determine the wind turbine rated speed, ie the wind speed at which the power coefficient is at its maximum, and to some extent the wind turbine design (hub height, blade design, etc). However, most often the design parameters have already been fixed by the manufacturer, for the class of wind regimes he/she is aiming at and in such a way that mass production advantages are not impeded by custom designing turbines to each individual site.

This is equally true for design features such as pitch control, but to a much lesser extent for tip speed and electric generator (because generators and gear boxes, and by the way towers, are available in many sizes). The tip speed variations are limited by material strength considerations and by gear box exchange ratios and losses. The electric generator choice is hardly limited at all, at least not in the upwards direction (but of course, no benefits will derive from the extra cost, beyond a certain point).

Variable pitch angle involves a considerable addition of complexity to the rotor blade mounting and control, and adds significantly to cost (and probably diminishes lifetime as well).

The conditions under which pitch angle control may be desirable are when the power-in-the-wind distribution has a long tail at wind speeds much beyond the rated one. With fixed pitch angle, the power extracted reaches a constant value (some 30-40% above the rated wind speed), because in this region, the power coefficient drops as fast as the cube of the wind speed. Changing the pitch angle, the maximum power coefficient may be moved, and the power extracted in high winds may thus be increased (provided of course that a suitably large electric generator has been mounted). The extra expense of generator and pitch control may be paid for by the increase in annual energy production, provided that the extra power (high levels occurring during a few hours a year) can be utilised. This would be the case for grid-connected wind turbines constituting a small fraction of the total generating capacity. The conditions would rarely be fulfilled for wind-diesel systems.

Pitch control may also be used to expand the operating regime downwards. However, since the power in the wind diminishes as does the cube of the wind speed, there is in this case no significant change in annual energy production to help pay for the more complex design. On the other hand, for wind-diesel systems, the increase in the number of hours annually with some wind power production may positively affect the system economy. This would require that demand is sometimes a very small fraction of wind generator rating, because again the quantities of extra energy are insignificant. This condition is not fulfilled for the Malabar model considered in Chapter 4.

The parameter left to be optimised, once the diesel component and the wind turbine design has been fixed (Figure 43), is the wind turbine swept area, A , ie a measure of the size of the wind component. This optimisation is not independent of the operating and control strategies, which affect system behaviour and cost partly by modifying fuel consumption due to possible changes in diesel operation, and partly by introducing new equipment and thus adding to cost. For example, a short-term energy store may be required to prevent power loss while the diesel engine is started, or a variable capacitor bank to allow stand-alone operation of an induction generator-equipped wind turbine.

Table 1 lists four commonly considered operation and control strategies, examples of which (with modifications) can be found in the survey of ongoing experiments (Chapter 2). The first three modes of operation will be referred to below, in the discussion of the Malabar experiments. The fourth mode will not be considered here.

Table 1 Operation and Control Strategies
(wind turbine provided with induction generator)

Mode 1	Diesel always on. Dump (or controllable) load for frequency control.
Mode 2	Two diesel engines, one always on. Dump (or controllable) load for frequency control.
Mode 3	Diesel sometimes off. Controllable capacitor bank for voltage control, minimum 10 seconds energy store for continuity and dump (or controllable) load for frequency control.
Mode 4	As 3, but with energy store large enough to avoid ever dumping energy or running diesel at low load.

3.1 Short-term System Behaviour

Both the theoretical modelling of short-term transient behaviour (at diesel starts, sudden load variations, wind gusts, etc) and the verification of model results by actual experiments, have been performed as parts of some of the wind-diesel projects mentioned in Chapter 2.

The main consideration has been to maintain power quality by designing the system and its control system in such a way that frequency and voltage variations could be kept within acceptable limits. However, such limits have not been very stringent for some rural systems, such as the Fair and Lundy Island installations where loss of power during wind-to-diesel or diesel-to-wind switching has been accepted.

The conclusion that can be drawn from the experiments conducted so far is, that frequency stability to a satisfactory degree can be obtained with a controllable (dump or non-time-urgent) load system. Regulation steps can be chosen to match any prescribed frequency limits. As far as voltage control is concerned, the problem is significant only if the diesel engines are sometimes switched off.

Possible solutions include using a synchronous generator with voltage control for the wind turbine, or to add a controllable capacitor bank in conjunction with a standard induction generator. The Dutch experiment further looks at the possibility of leaving the synchronous generator of the diesel engine connected, while the engine itself is disconnected from the system.

A further problem occurs when the wind power suddenly drops to below load, while the diesel engine is off. Several of the ongoing experiments suggest that this should be dealt with by adding sufficient energy storage to cover the diesel upstart period, with the preferred device being a flywheel. Flywheel storage is selected because of the high levels of power that can be drawn from it, and its convenient incorporation into the drive train, eg in conjunction with a gear box (in order to allow suitable flywheel

rotational frequencies). The problem is that conventional thin-rim flywheels have unfavourable cost-to-performance ratios, while modern flywheel technology is still in an emerging stage and associated with many uncertainties [Jensen and Sorensen, 1984].

Conventional lead-acid batteries may constitute an alternative, but the maximum discharge rate is a limiting factor. If 100 kW has to be supplied during 5 seconds, while the diesel engine is starting, then nominally, a 0.15 kWh battery would suffice. However, less energy can be extracted at high discharge rate, and the maximum power to energy ratio is limited to about 100 h^{-1} , ie

$$\text{Power (kW)} * 0.01 \text{ (h)} = \text{Energy (kWh)}$$

[Jensen and Sorensen, 1984, p 34]. Furthermore, only 8% of the rated energy can be extracted at the highest power level [Jensen and Sorensen, 1984, p 178], so that the battery rating must be at least 12.5 times larger than the energy appearing in the relation above. In order to sustain power extraction at the level of 100 kW, the battery would then have to be rated at about 15 kWh, rather than 0.15 kWh. Thus a battery store corresponding to some 10 minutes of maximum load is needed in order to cover the power that may be needed during diesel upstart. In addition, a rectifier/inverter unit will have to be added.

A number of non-conventional generators have been researched, with the purpose of converting variable shaft speeds into fixed frequency electric power. Examples are the Roesel generator [Johnston, 1985] and the VSI generator [Woychick, 1984]. None of these devices for short-term control are in commercial production, and it would seem that the market is too small to warrant the type of mass production that has made conventional generators reach their present price level.

3.2 Modelling Average Behaviour

Once convinced that the short-term fluctuations are being taken care of by appropriate features of system design and control, one may turn to the issues of primary interest. How will the system perform on average over extended periods of time.

In the case of an actually operating system, such average behaviour will of course be measured. However, before deciding on system size and operating strategy, model calculations may be performed with the purpose of optimising the economy of running the system, as well as optimising the initial investments.

It is thus relevant to perform two kinds of computer modelling for wind-diesel systems. One is the transient behaviour modelling, the results of which are decisive for the technical design of control components. These calculations will normally not have to be repeated for every new installation, because they are little dependent on external factors. For instance, the results of model calculations such as those performed by Tsitsovists and Freris [1983] or by Elder et al [1985] are relevant for all wind-diesel systems of similar structure.

The other type of modelling effort deals with long-term average performance and is evidently highly dependent on site-specific parameters, notably wind speed patterns and load variations. Such calculations will be presented in the following, for a Malabar-type system and using Malabar wind data, but with auxiliary cases being considered in order to estimate the changes associated with moving the wind-diesel setup to other NSW locations.

The features of the real system which are lost by modelling only average behaviour, eg based on hourly wind speed and load averages, are as follows:

In the operation mode where diesel engines are turned off and on, the conditions for stopping and later starting the diesel set may be fulfilled several times during one hour. The number of diesel starts may thus exceed that obtained from the hourly simulation model. This may be avoided by requiring that once the diesel is started, it must run for a minimum of one hour, regardless of wind conditions. This condition is in any case a very reasonable one, which could be built into the control procedures.

More serious is the situation of having sufficient average wind power during a given hour to allow the diesel engine to be turned off, but yet the actual wind may sometimes drop below the level needed for satisfying the load alone. In this case the diesel would be turned on (and would operate for an hour according to the criterion given above), but its fuel use would not appear in the model results. To minimise the occurrence of such situations, the conditions for turning the diesel engine off are taken not only to be that the wind power production is safely above load, but also that the wind turbine is not operating on the steep part of the power curve (see Figure 54), but at or near the flat region of rated power output.

The Dutch group [Bonte et al, 1985] has found that the ratio of minimum to mean wind power during ten minute intervals behaves as shown in Figure 44, for their system with two identical wind turbines. The "firm power" at wind speeds giving near full power output is seen to be only half of the average power level. There are indications from other studies, that the situation is improved at higher wind speeds, corresponding to operation near the stall point [private comm. of measurements on Danish wind turbines].

There is no difficulty in the operational mode where the diesel is always on, neither when more-than-minimum energy storage is added (mode 4 in Table 1). In any case, the issue is related to the accuracy of model calculations, not to the actual operation of wind-diesel systems in mode 3, ie with the diesel sometimes off.

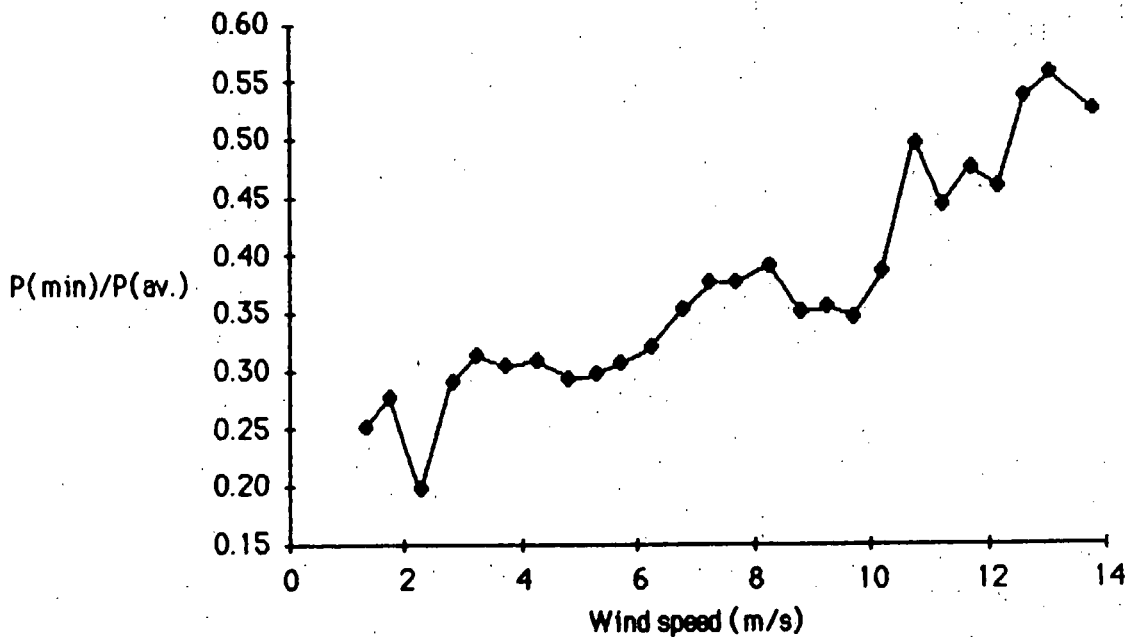

Figure 44. Ratio of minimum and 10 minute average dual wind turbine output, as function of average wind speed [Bonte et al, 1985]

3.3 The Malabar Test Facility

Figure 45 shows the likely lay-out of the Malabar facility and its possible future expansion (dotted lines and components). A gas engine will be used instead of a diesel engine during some of the experiments, but the behaviour of the two engine types are fairly similar. It is expected that a smaller diesel engine will eventually be installed, so that the mode 2 (Table 1) experiments can be carried out, with the gas engine sometimes switched off, but the smaller diesel engine running continuously. The capacitor bank and perhaps a modest battery store will be needed in order to test the mode 3 (of Table 1) operating strategy. The relative placement of transformers and components (Figure 45) is made for non-technical reasons.

4. MODEL CALCULATIONS

The following sections describe a simple simulation model based on hourly time steps and aimed at predicting the average behaviour of a wind-diesel systems similar to the Malabar facility, under various conditions as regards load, wind resource and operational mode. The results will be easy to translate to other conditions relevant for alternative sites in New South Wales or elsewhere.

The simulation program, used for calculations in this chapter, together with a sample run, are given in Appendix 1.

4.1 Load Pattern

The model load is described as an average behaviour as a function of time-of-day and month, overlaid with a stochastic component of a certain amplitude.

The annual average load in the actual calculations were fixed at $LA=50$ kW. This is an arbitrary choice, and all results scale linearly with LA , so that other values can readily be introduced.

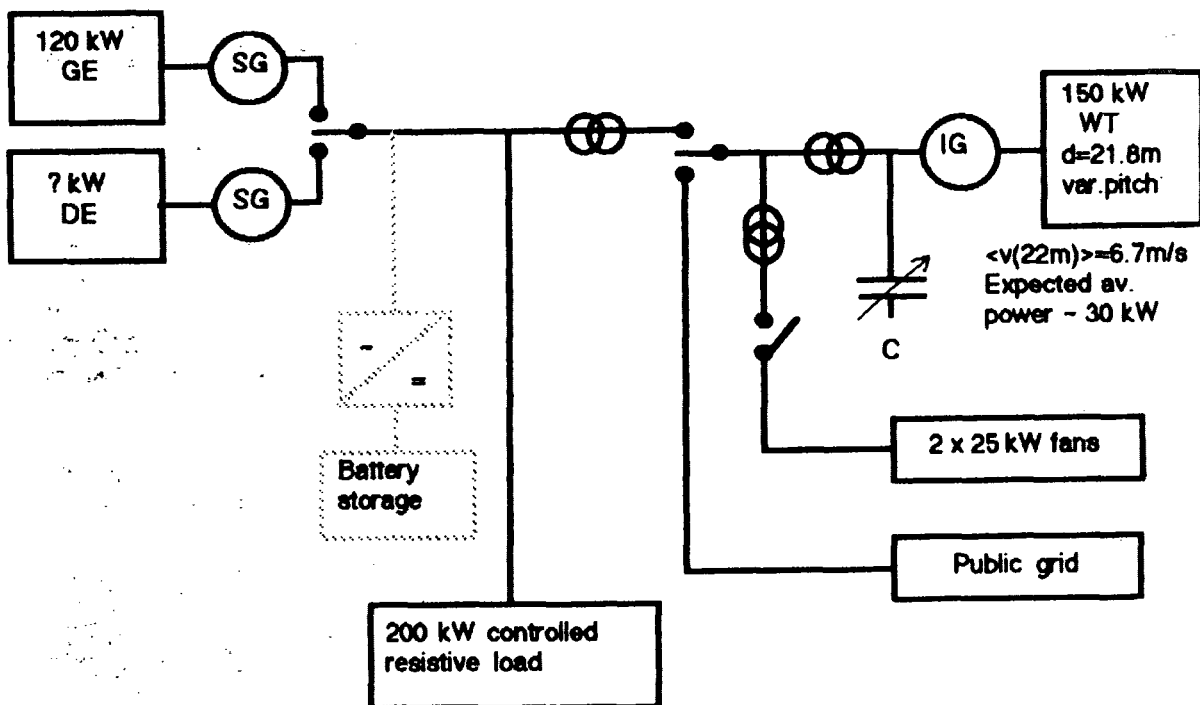

Figure 45. Malabar wind-diesel/gas system
(GE = Gas engine OO = transformers)

A simplistic diurnal load curve for isolated NSW communities is shown in Figure 46. It has been used for a number of the simulations, along with the assumption of no seasonal load variation. This is not too different from measured load variations on Lord Howe Island, which can be found in

Barker et al [1983, p 54]. The amplitudes of randomly generated load fluctuations are taken to be in the range of plus/minus 10% of the daily average load.

The maximum load is thus 1.6 times, and the minimum 0.4 times the daily average. Whenever wind turbine ratings above the minimum load are considered, the possibility of having to dump wind-produced power must be taken into account.

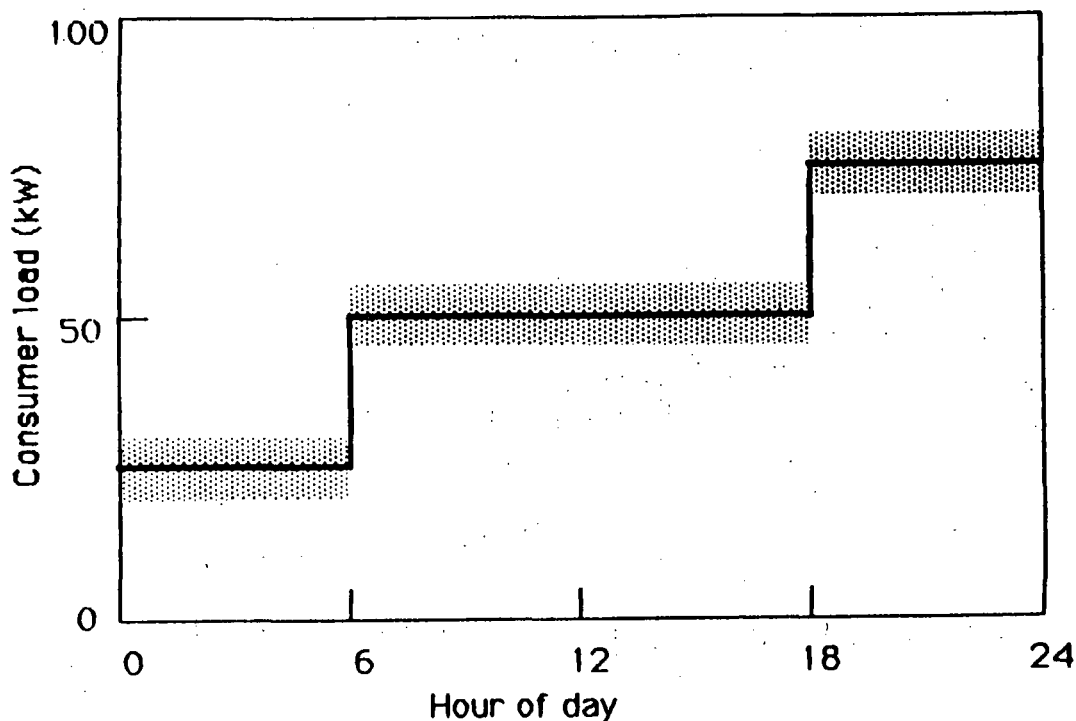

Figure 46. Model of diurnal load variations

The maximum load determines the necessary diesel backup, because the wind power production may be zero at the time of maximum load. As mentioned, a security factor is usually built into the choice of diesel rating. The model assumes the diesel rating to be RD=100 kW rather than 80 kW (the maximum load).

Some of the calculations are performed with constant (diurnal and seasonal) load curves, in order to check the influence of removing special correlations that may exist between wind and load patterns. The plus/minus 10% random fluctuations are included in all the calculations.

4.2 Diesel Engine Fuel Characteristics

The fuel use of a number of diesel generators rated in the range of 70 to 500 kW have been assessed. Figure 47 shows measured fuel values for a 70 kW diesel generator [Crawford, 1985], as function of the load level. Curves for other diesel engines show almost identical shapes with small vertical displacements. The effect of these differences is largest for the idling fuel consumption (denoted F0), which range from about half to about twice the figure found in Figure 47. The effect of these variations will be discussed in Section 4.13. In the remaining calculation, the fuel curve of Figure 47 has been used directly.

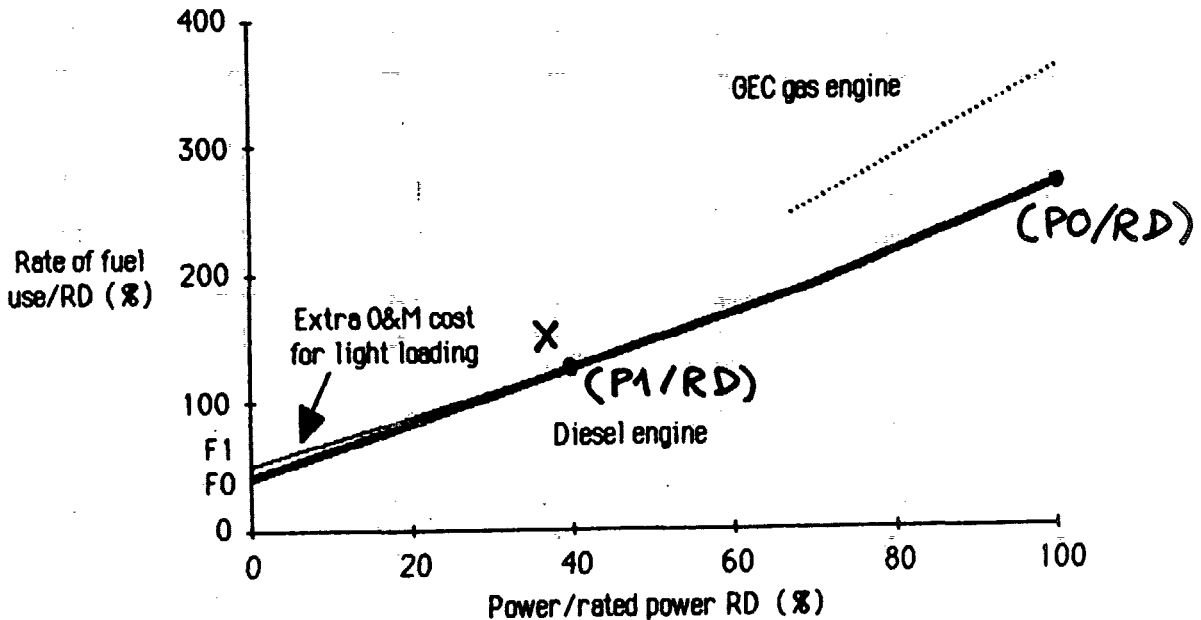

Figure 47. Assumed diesel fuel consumption as function of load (note that the left-hand ordinate is kW (fuel value) divided by rated kW (electrical)). Values below 25% load have been extrapolated from data. The area F1-X-F0 represents the fuel equivalent of an assumed extra operation and maintenance cost associated with light load running.

Several diesel manufacturers recommend that the engines are not operated for extended periods (such as days) at a small fraction of rated power. The tolerable load levels are in some cases quoted as 40% of rated, in other cases as 25%. A remedy often quoted is to let the engine run near rated power for a short period every day. This is similar to the operation of diesel engines in cars and trucks, where the average load is often under ten percent of the engine rating, but where high power levels are associated with starts and occasional accelerations.

In the model calculations, it has been assumed that low load operation is allowed, but that it will result in a higher cost, attributed eg to operation and maintenance or directly to the fuel cost, which may be appropriate if the control system of the wind-diesel installation interrupts low load operation of the diesel engine by occasionally bringing the engine up to rated power (and dumping the extra energy produced). Other types of extra costs resulting from light load running may be in the form of conventional O & M expenses: more frequent oil changes and cleaning.

The extra cost is modelled as equivalent to a certain fuel expense, rising from zero at the power level $P=P_1$ (=40% of rated), to a value corresponding to the rate (F_1-F_0) of fuel use, when P has declined to zero (idling). This behaviour is indicated in Figure 47. The effect of varying F_1 , a quantity for which no actual data could be found, is discussed in Section 4.13.

4.3 Wind Characteristics at Malabar

Wind speeds at Malabar headland have been monitored by the Energy Authority for 4.5 months in 1984 [Watt and Harrington, 1985]. The recalibrated frequency distribution of wind speeds, hour-of-day and weekly means, and directional distribution are shown in Figures 48-51 [communication from L. Harrington]. More data are needed to ascertain the seasonal variations, so the simulation model is taken to include no seasonal effect. A smoothed version of the basic distribution is obtained as the sum of two Weibull distributions⁺, as indicated in Figure 48. It has not been possible to fit the high peak and long tail with a single Weibull distribution. In any case, the Weibull distributions are just used for convenience: they have no theoretical foundation in the theory of atmospheric circulation. An attempt has been made to see if the tail distribution should be specifically linked to the sea-breeze effect occurring from Noon to about 20 h (Figure 49). However, even the distribution for the hour 16-17 (representing the diurnal peak) has a complex shape with two maxima (Figure 52). Directional wind speed distributions are shown in Figure 51.

In the model calculations, the wind speed for each hour is randomly picked from the smoothed distribution shown in Figure 48, using distribution (a) for 62.5% of the time (hours 21 to 11) and distribution (b) for 37.5% of the time (hours 12 to 20). This assignment associates the distribution stretching into the high-velocity regime to the hours of sea-breeze enhanced average wind speeds (see Figure 49), and the distribution peaked at 4.5 m/s to the remaining hours. This is likely to overemphasize the effects of the sea-breeze system, and may hence overestimate correlations with diurnal load curves such as the one shown in Figure 46. In order to make sure that this is not the case, all calculations were repeated with a constant load (plus the random fluctuations discussed in Section 4.1).

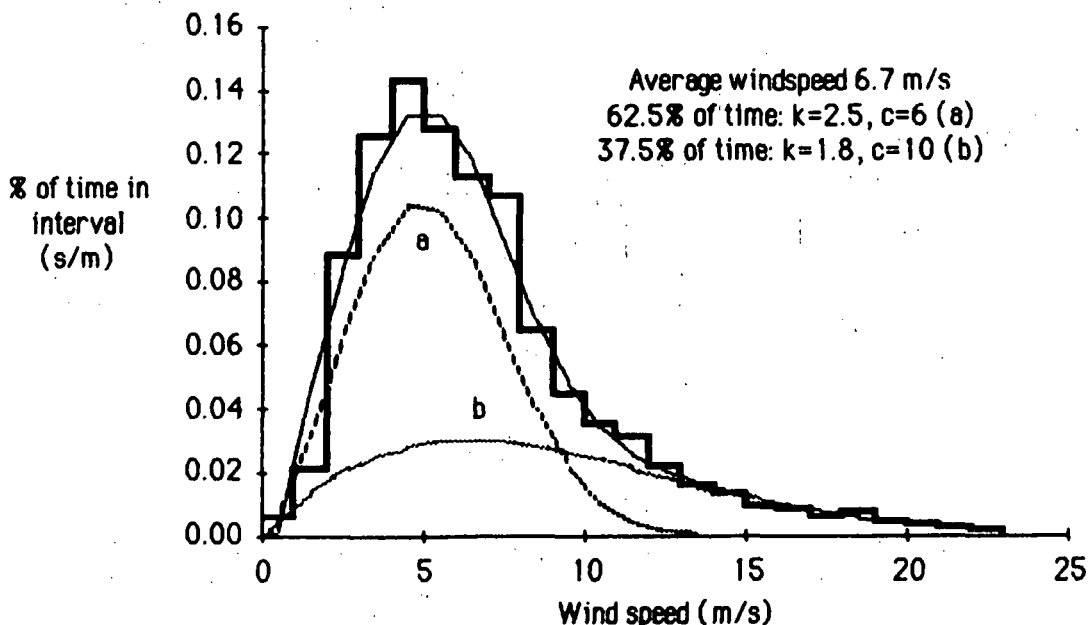

Figure 48. Measured frequency distribution of wind speeds at Malabar (height 22 m above ground). Data are 30 min averages. A fit composed of two Weibull distributions is indicated.

⁺ The Weibull distribution is given by $f(v) = \frac{k}{c} \left(\frac{v}{c}\right)^{k-1} \exp \left[-\left(\frac{v}{c}\right)^k \right]$

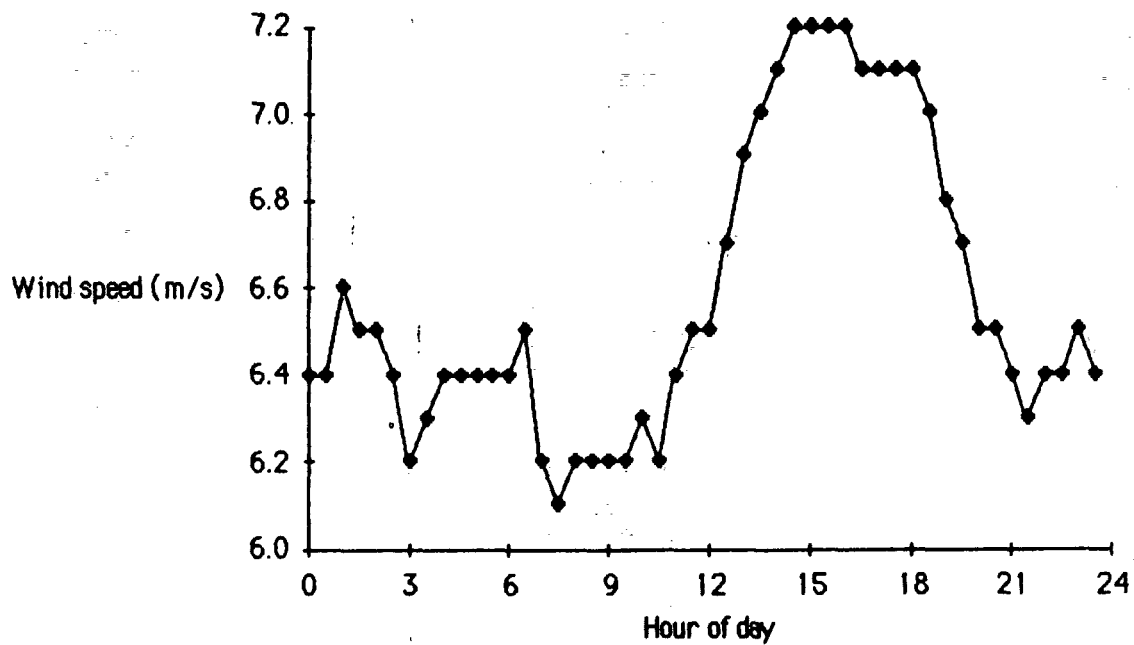

Figure 49. Measured hour-of-day average wind speeds at Malabar, 22 m

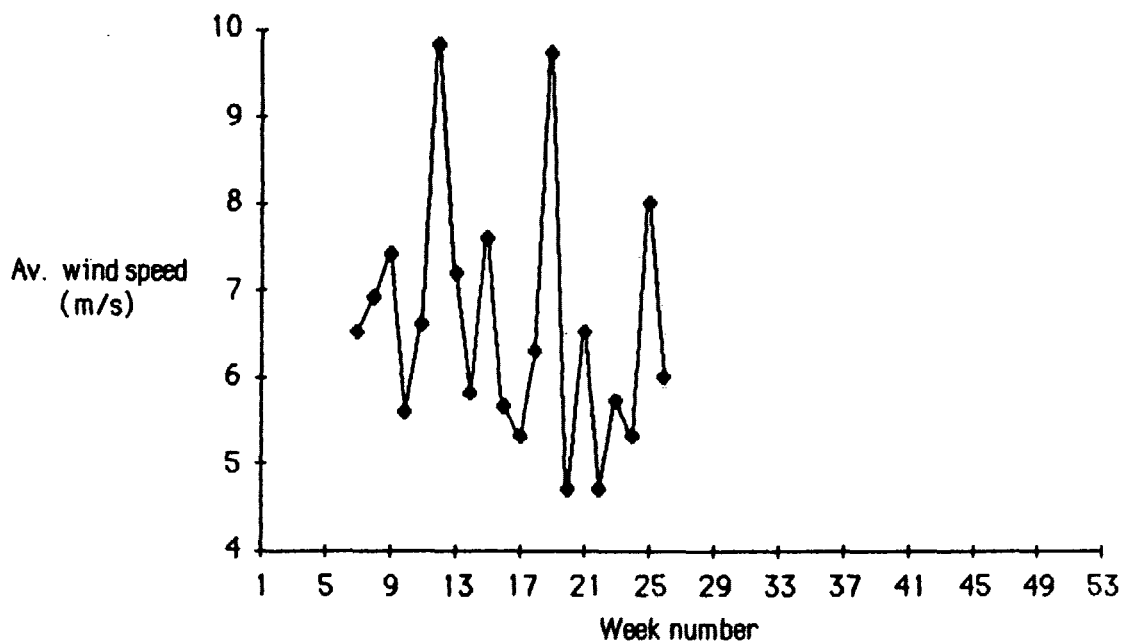

Figure 50. Measured weekly average wind speeds, 10 February to 22 June 1984, at Malabar, 22m.

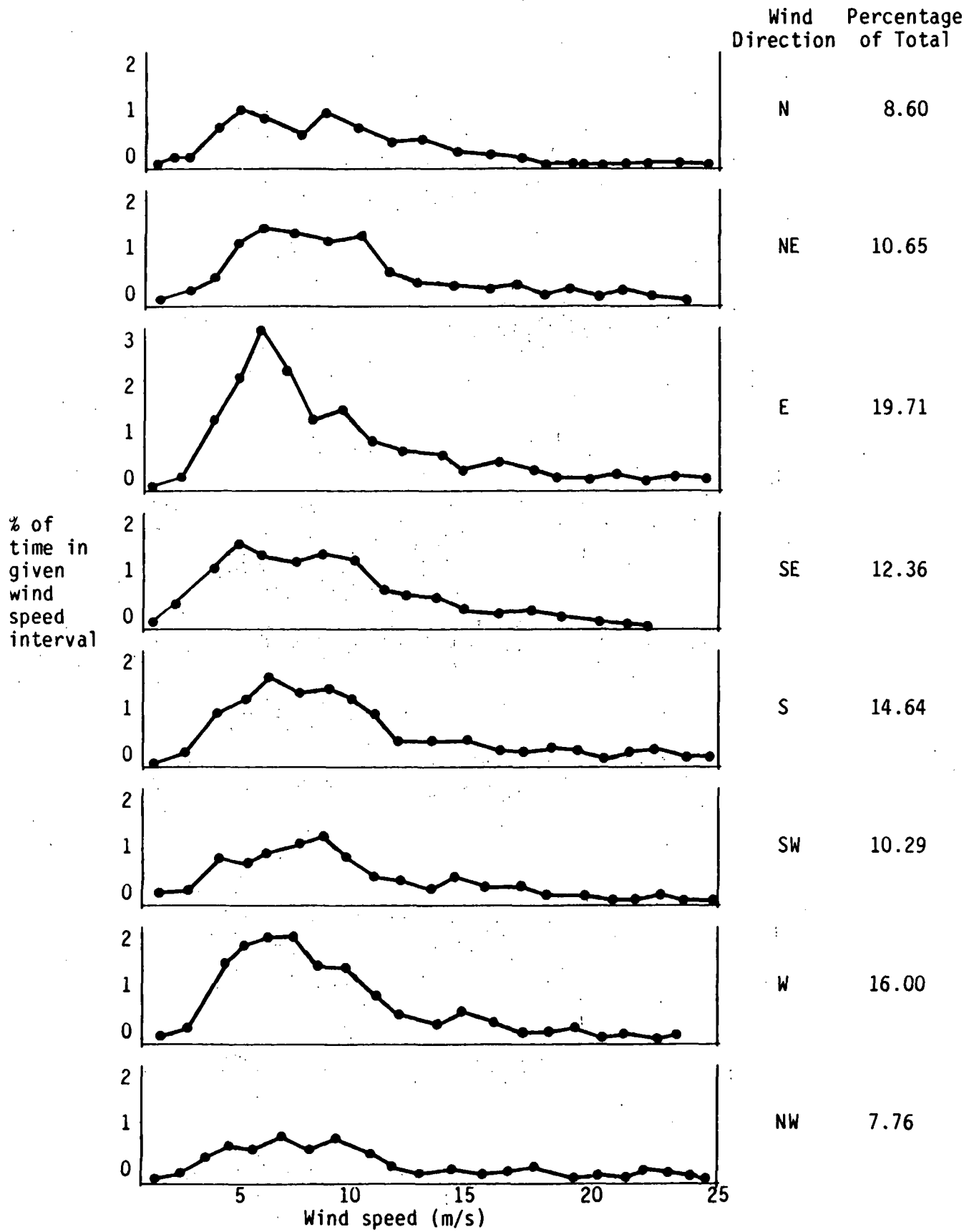

Figure 51. Measured directional frequency distributions of wind speeds at Malabar, 22 m.

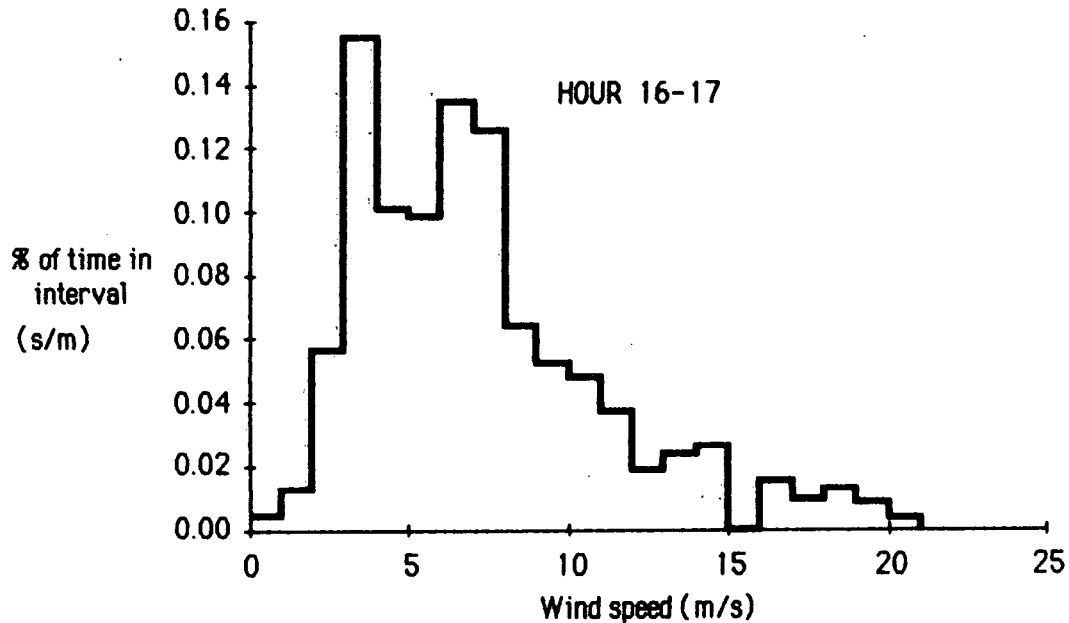

Figure 52. Measured frequency distributions of wind speeds at Malabar, 22 m, for one particular hour-of-day

4.4 Wind Turbine Design

The distribution of power in the wind, based on the 30 minute averages of Figure 48, is shown in Figure 53 (solid line). There may be some underestimation of power levels, because the 30 minute average of the cube of the wind speed is higher than the cube of the average. However, inspection of wind spectra shows that most fluctuations have periods either above 30 minutes or below 2 minutes, so that the extra power may occur in boosts too short to be useful. In fact, using averaged wind data rather than average power data may eliminate some of the short-term modelling problems discussed in Section 3.2.

The ideal procedure in selecting a wind turbine design for a given location would be to match the power coefficient curve (ie the turbine shaft power relative to the power in the wind, as a function of wind speed) to the actual power distribution. This is not easy to do for a two-peak distribution such as the one for Malabar shown in Figure 53. Also, caution should be taken in using that curve too rigorously, because of the short sampling time. Other seasons and other years may exhibit different distributions of the power in the wind.

Superimposed on Figure 53 is the power coefficient of the turbine actually purchased for erection at the Malabar site (based on manufacturer's brochure). The power curve used in the simulation is typical of a number of commercial wind turbines. It is shown as (a) in Figure 54, together with manufacturer's data for the HMZ machine planned for Malabar (HMZ gives data relative to wind speed at 10 m, not hub height, but these have been translated back to hub height, using the wind shear factor quoted by the manufacturer).

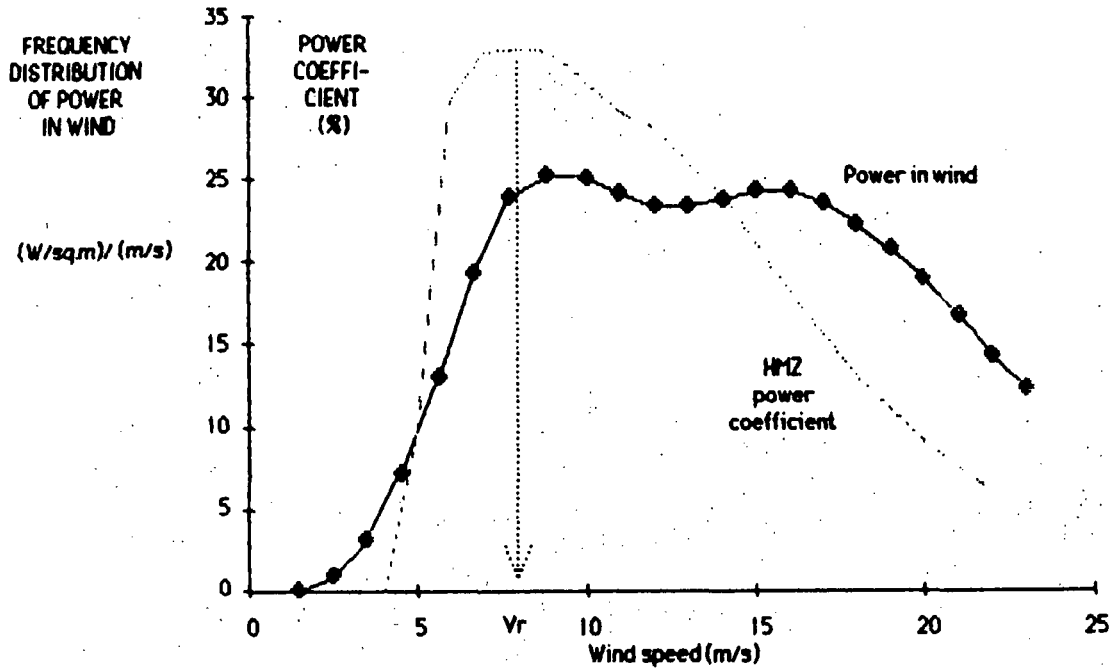

Figure 53. Frequency distribution of power in the wind at Malabar, 22 m, based on 30 min. averages (full line), and power coefficient of HMZ turbine (dashed line, manufacturer's data). Power coefficients depend only on the ratio of the wind speed and the blade tip speed (here 60 m/s).

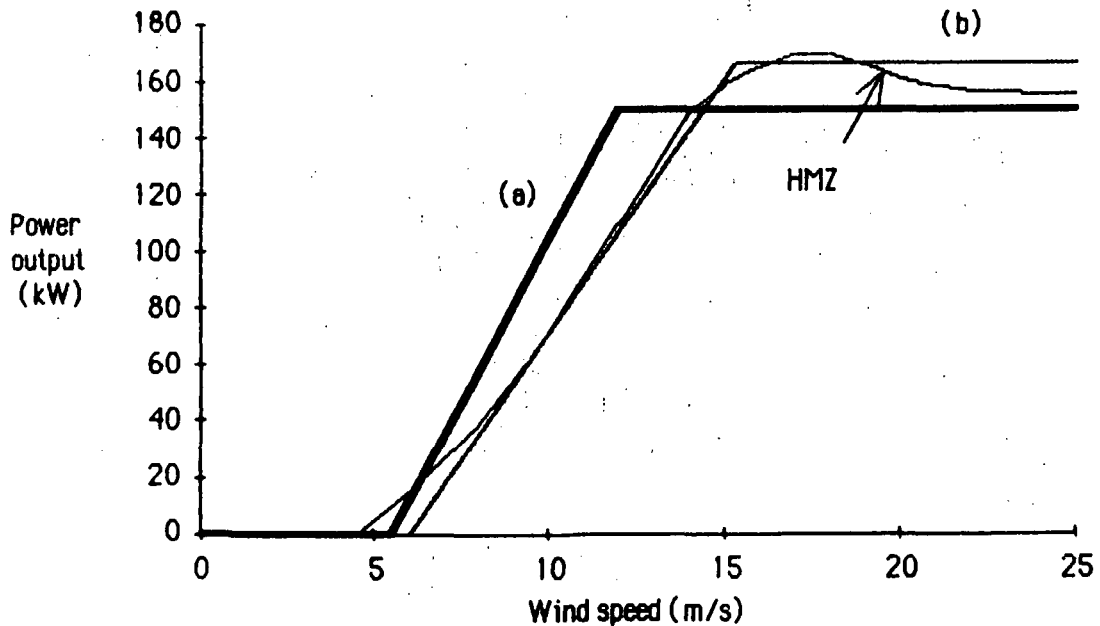

Figure 54. Power curve used in simulation study (a: heavy line), and power curve of HMZ turbine (thin line, manufacturer's data). The alternative fit (b) to the HMZ turbine shown as a dashed line has been used in model calculations described in Section 4.13.

For single-peak curves one would have chosen the wind speed giving the maximum average power per windspeed interval as the rated windspeed v_r (ie the windspeed for which the conversion efficiency is maximum). Pitch control allows the turbine peak efficiency to move, but a prescribed wind speed dependence on pitch angle setting has already been built into the power curve for the HMZ 150 kW turbine.

The full power level can be changed without altering blade aerodynamics, by changing rotational speed (within limits imposed by materials and technology). The HMZ manufacturer offers several speeds (and associated electric generator ratings) for the same turbine, of which the 150 kW machine is the "middle one". This is illustrated in Figure 55, where a number of wind turbines are plotted in a rated power vs swept area diagram. In the model, calculations aiming at optimising the swept area for a given average load, a fixed relationship of 100 kW rated power to 300 m² swept area has been assumed, in accordance with the trend of the most commonly sold wind turbines.

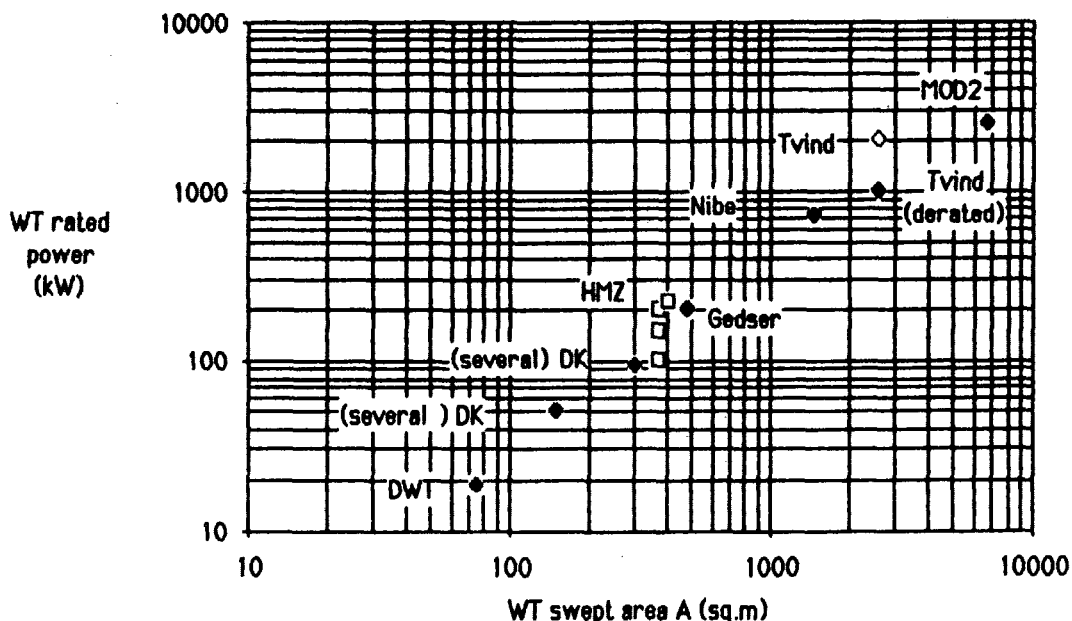

Figure 55. Rated power vs swept area for selected wind turbines

4.5 Power Production

Model results are presented as a function of wind turbine swept area, A . The average load and diesel rating are fixed at 50 kW and 100 kW, respectively. Figure 56 gives power production by wind and by diesel, as well as the amount of energy that has to be dumped. The simulations have been extended to lengths of time for which the results are statistically significant, ie for which the stochastic elements in the load and wind speed modelling no longer have a significant influence on the results.

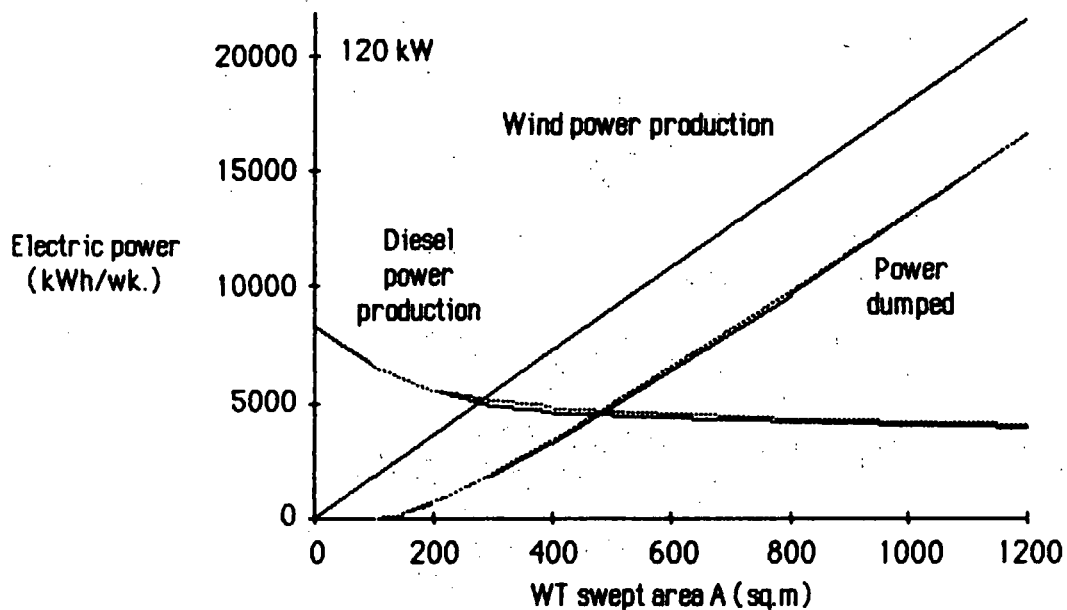

Figure 56. Simulation results of electric power production by wind and by diesel, plus power delivered to dump load. Full curves: Diurnal load variation as in Figure 46. Dashed curves: no systematic diurnal variations.

The effects of the diurnal load model are seen to be minimal. A look at the power dump profile already suggests an economic optimum at or below $A=200 \text{ m}^2$.

The results in Figure 56 are independent of whether the diesel is running continuously (mode 1 in Table 1), or is turned on and off (mode 3 in Table 1).

4.6 Fuel Savings

Figure 57 shows calculated fuel savings as a function of wind swept area, for continuous diesel operation (mode 1) and intermittent diesel operation (mode 3). For comparison, the fuel saving for a grid connected wind generator is also shown, ie a wind generator operating purely as a fuel saver in an "infinite" diesel powered system. Due to wind-produced power not always being demanded, and therefore increasingly (with increasing A) being dumped, the actual curves bend over and saturate at fuel savings of about 40%.

The conditions for turning the diesel off in mode 3 are:

- (i) wind power over load exceeds 1.2
- (ii) wind power over rated wind power exceeds 0.8.

Modifications of these conditions will be discussed in Section 4.7.

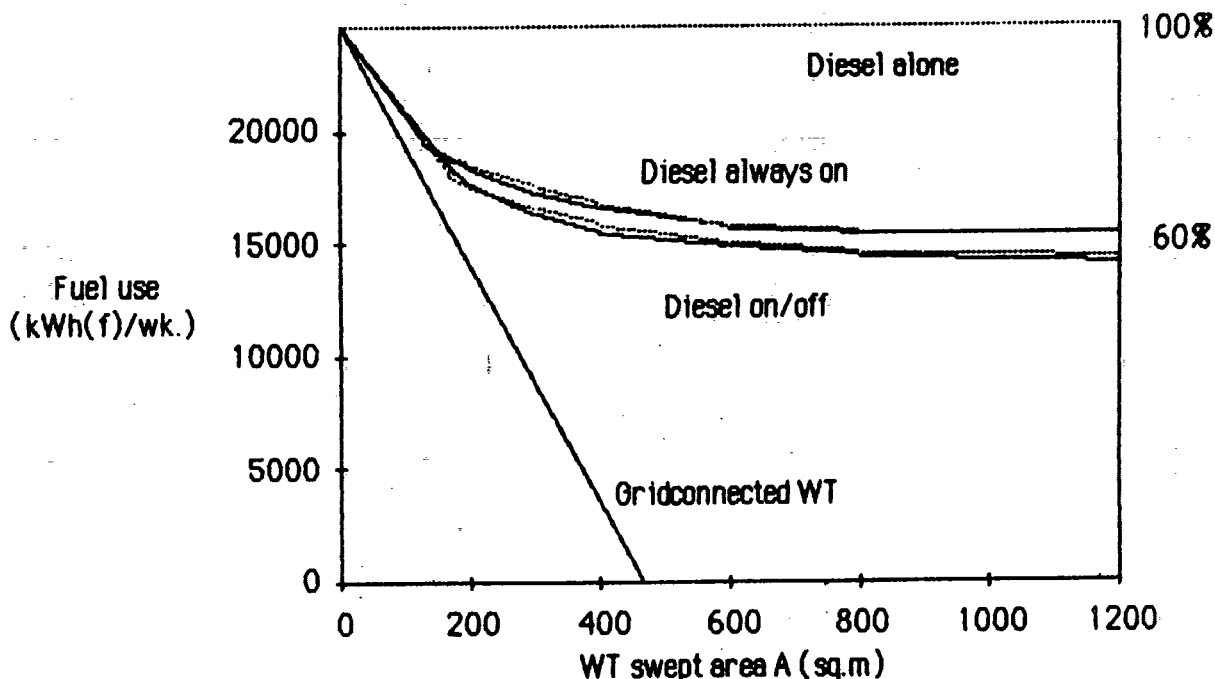

Figure 57. Fuel use for diesel alone, for grid-connected wind turbine, and for two modes of wind-diesel operation. Dashed curves assume no diurnal load variations, full curves include such variations according to Figure 46.

4.7 Diesel Starts In On/Off Mode

Each diesel start involves additional costs, associated with heating of materials to operating temperature, and perhaps inducing incremental needs for O & M. The extra fuel consumption for upstart has been measured by Bonte et al [1985], and found to correspond to full rated power fuel consumption for a period of a few seconds (see Figure 19). Since the operation of the wind-diesel system would limit the number of diesel starts to at most one or two per hour, the upstart fuel costs are negligible.

The conditions for turning the diesel engine off in mode 3 operation were given in Section 4.6. The corresponding number of diesel starts and hours of diesel turned off are shown in Figure 58, for varying load and stochastic wind data. Only above 100 m² wind swept area will it be possible to switch off the diesel. Some 15 diesel starts per week is quite an acceptable number, and it does not increase with further increase in wind swept area. The reason is that the diesel is turned off precisely when the wind turbine output equals the full rated power, and increased area just means that more energy is being dumped during these hours, as seen from Figure 56. The reason that partly loaded wind turbine hours do not manage to cover the load with increasing swept area, so that the diesels can be switched off, is the second condition, that wind-produced power must exceed 80% of the rated power. The frequency distributions shown in Section 4.15 show that the wind power will anyway lie in the middle interval only for a small percentage of time.

The use of stochastic wind data ignores the correlations between wind speeds of adjacent hours, and would thus give an upper limit for the number of diesel starts required (whereas the number of hours during which the diesel would be shut down will be correctly predicted).

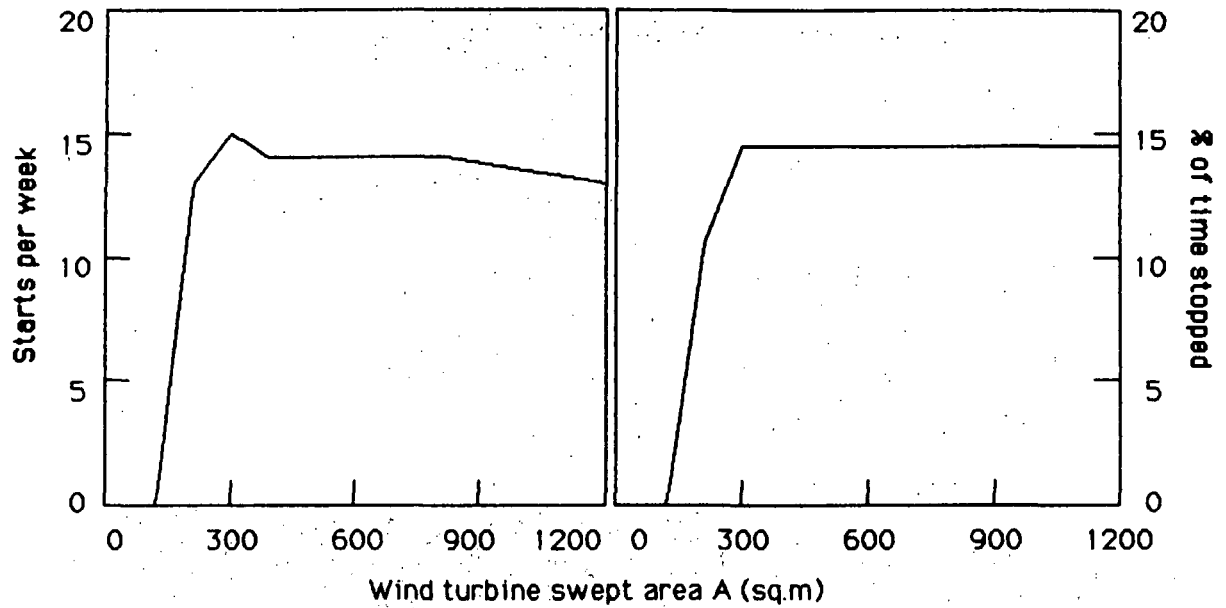

Figure 58. Number of diesel starts (left) and percent of time diesel is off (right), assuming diurnal load variations and mode 3 operation.

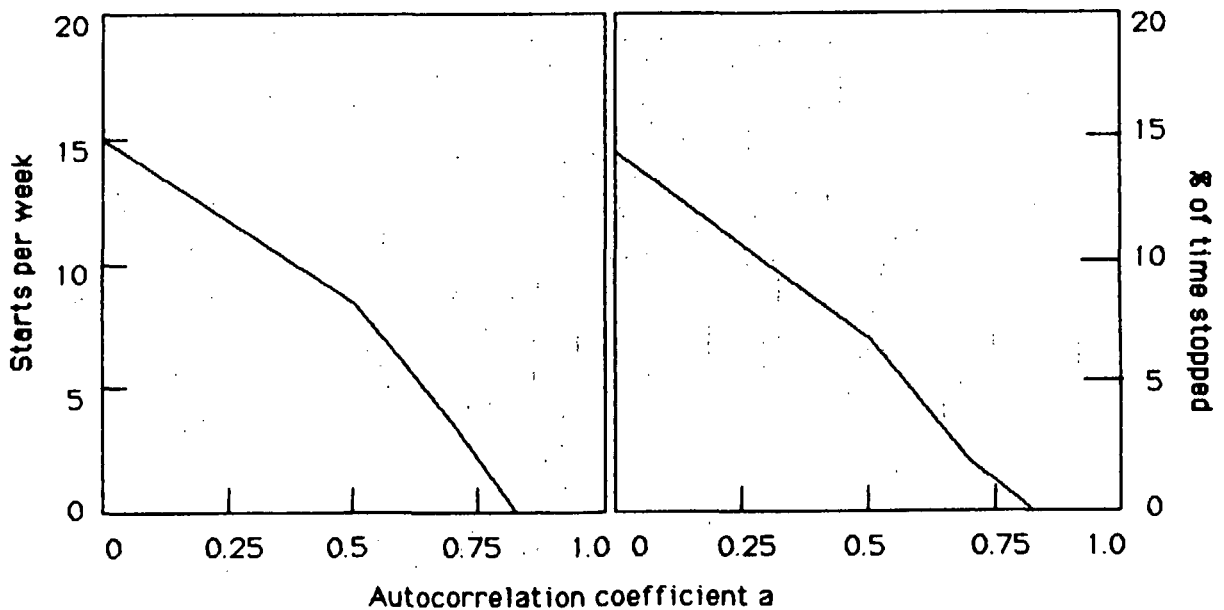

Figure 59. Number of diesel starts for 200 m² wind swept area, as function of the auto correlation coefficient, a , between wind speed in successive hours.

In Figure 59, the effect of introducing correlations between the selection of model windspeeds for successive hours is studied. If $R(h)$ denotes the random windspeed picked for the hour h (from the distribution in Figure 48), then the actual windspeed $v(n)$ used for that hour may be taken as:

$$v(h) = a v(h-1) + (1-a) R(h)$$

As a increases, the range of fluctuations narrows, and very long simulation times are required in order to recover the original wind speed distribution. The number of diesel starts decreases, because the correlations increase the likelihood that the diesel may be left off, if it was off during the previous hour. Since the number of diesel starts predicted by the model is anyway too modest to cause any problems, all other model runs were made with $a = 0$, allowing for short simulation periods (1 week).

The discussion in Section 3.2 suggests that the diesel-off conditions presented in Section 4.6 may not be stringent enough. Figure 60 shows the effect of raising the condition on wind power to load ratio from 1.2 to 2.0, and of raising the condition on wind power to rated power from 0.8 to 0.9. In neither case are there any dramatic effects on diesel starts or on lengths of diesel-off periods. Again the reasons are to be sought in the fact that the second condition ensures that more than 120 kW (135 kW) is produced by wind (for $D1 = 0.8$ (0.9)), and the first condition ensures that the load is below 125 kW (75 kW) (for $D0 = 1.2$ (2.0)). The significance of the more stringent conditions is that they ensure instantaneous load can always be met within an hour during which the average wind power meets the requirements. In other words, the behaviour of the system on timescales below that of the simulation model used can be assured in this way. The result of these considerations is that the sub-timescale behaviour of the system will not alter the economic conclusions derived from the hourly simulation model.

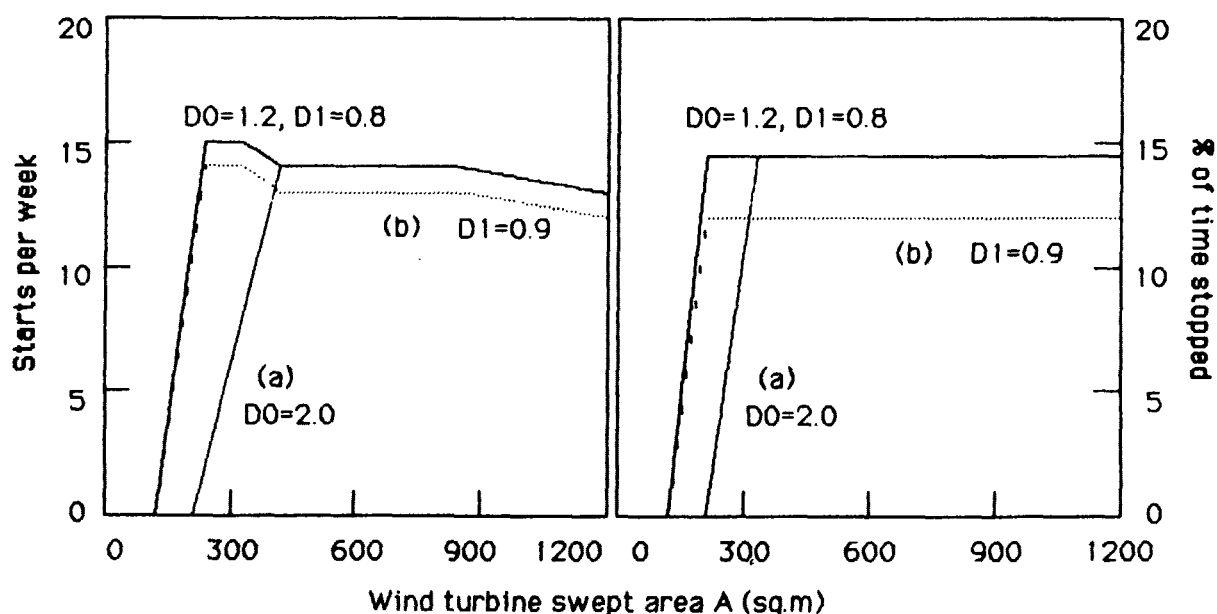

Figure 60. Number of diesel starts (left) and percent of time diesel is off (right, assuming constant load and diesel-off criteria (1.2/0.8, cf. text). Also shown are two alternative calculations (a: 2.0/0.8) (b: 1.2/0.9).

4.8 Economics of Wind-Diesel Systems

The economic assessment associated with the wind-diesel model calculations are divided into a base-case study using very transparent price estimation techniques, and a number of alternative cases aimed at illustrating the robustness or lack of robustness of conclusions, and at introducing price estimates considered more realistic (but also more complex) than those of the base-case. This section describes the base-case results.

There are two basic price variables in the model: The fixed charge FC (Aus. cents per kWh delivered to load) and the fuel price F (Aus. cents per kWh fuel value; 1 c/kWh(f) is approximately 10 cents per litre for diesel fuel). The fixed charge may be written as:

$$FC = \frac{100}{L} \sum_i C_i (CR + OM_i) \quad (\text{Aus. cents per kWh (e.)})$$

where

L = kWh's delivered annually to load (= 50 kW * 8760 h/y)

CR = capital charge rate (0.10 per year for base-case)

C_i = capital cost of i'th system component (Aus.\$)

OM_i = operation and maintenance costs for the i'th component (taken as 0.02 per year for all components, in base-case)

The capital costs for the base-case are taken as:

C = 900 (A\$/m²) * A (m²) for wind generator, site costs, controls, and ancillary equipment such as dump load, capacitor bank, inverter etc., if required

A = wind turbine swept area

C = 500 (A\$/kW) * RD (kW) for diesel engine, generator and controller

RD = diesel rated power

The base-case fuel price is taken as:

F = 7 c/kWh(f) or 70 cents per litre

In mode 3, the cost of battery store and battery replacement may have to be added. As discussed in Section 3.1, the battery capacity has to be 15 kWh. Assuming a battery cost of 130 A\$/kWh, this would amount to about 2000 A\$. If battery life is taken as 2500 cycles (no deep discharge would be taking place, cf Outhred [1985]), and 800 applications per year are envisaged (corresponding to 15 assisted diesel starts per week, cf. Section 4.7), then batteries would have to be replaced every three years. The associated

cost distributed on the units of energy delivered is $70\,000/L = 0.16$ c/kWh. FC is thus to be increased by this amount in mode 3 operation. The capital costs for inverter and capacitor bank are considered to be within the uncertainty of the main capital cost items listed above. If the extra costs were say \$40,000 for Rectifier/Inverter and capacitor [each 100kVA], then the power cost would be increased by 1¢/kWh. This roughly equals the difference between continuous and on-off cases in Figure 61.

Figure 61 gives the base case results as regards average cost of delivered energy, as a function of windswept area A . For reference, the constant cost levels for diesel alone and for a grid-connected wind generator are indicated. The remaining curves represent mode 1 and mode 3 operation (see Table 1 in Section 3.0), with or without diurnal load variations. In the following, the case without load variations, except for the stochastic ones, will be used as the base-case.

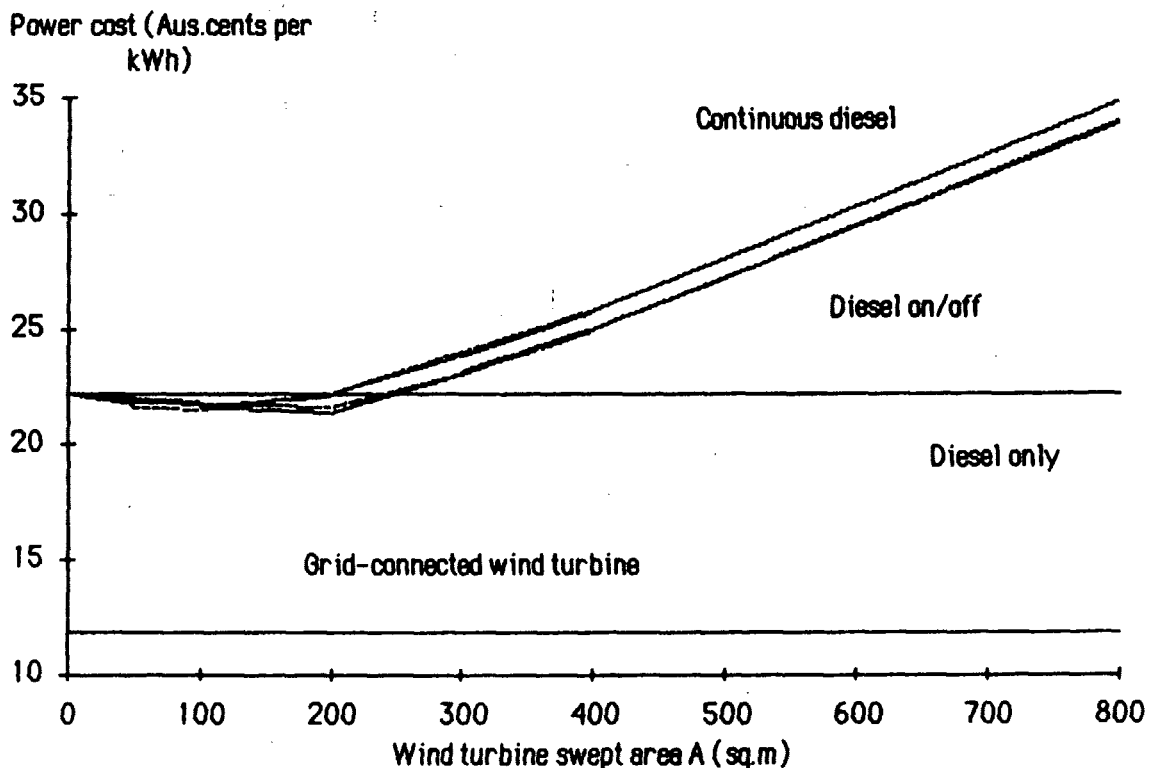

Figure 61. Base-case energy costs for wind-diesel systems in different modes of operation. Dashed lines are results of calculations suppressing diurnal load variations.

Beyond about $A = 200$ m², the extra cost of a larger wind turbine is not giving any return, because the extra power produced is being dumped (cf. Figure 56). There is an economic optimum for a turbine swept area of about $A = 100$ m² for continuous diesel operation (mode 1) and at about $A = 200$ m² for diesel on/off operation (mode 3). In both cases it is possible to obtain energy costs below that of pure diesel systems, but not much below. Most of the fuel savings are compensated by the capital investments necessary for obtaining the fuel savings.

Broadly speaking, the model suggests that within an uncertainty of about 5%, any wind system up to 200 m² (if diesel is operated continuously) or 300 m² (if provisions are made for intermittent diesel operation) is economically acceptable and roughly as viable as diesel alone. This may be interpreted as suggesting that it is not worthwhile bothering to introduce wind turbines into diesel systems in remote areas, but it could equally well be interpreted as a green light for wind-diesel systems, arguing that they produce energy with no additional cost as compared with pure diesel, but give a number of indirect economic advantages, such as reduced dependence on international oil prices, improved environment, local employment etc.

4.9 Capital Charge Rate

The base-model is very crude in using a fixed capital charge rate (10% p.a.) rather than employing a standard depreciation model. The reason for making this choice is the transparency of results based on a simple charge rate, that may be varied, rather than to have to estimate life times for each piece of equipment, interest rates, future fuel costs, inflation and so on. The uncertainty in these quantities, as they affect life cycle cost models, is presently so large that little insight can be derived from enlarging the number of parameters in this way. In particular, the outlook for the national and international economies is currently so uncertain, that depreciation models proposed today may appear as ill chosen in a few years as some models from a few years back do today.

The sensitivity of the economic model may thus be best illustrated by showing the effect of altering the capital charge rate, CR. Figure 62 shows the effect of reducing CR from 10% to 7% p.a., for mode 3 operation (diesel sometimes off). The high sensitivity to the charge rate is evident.

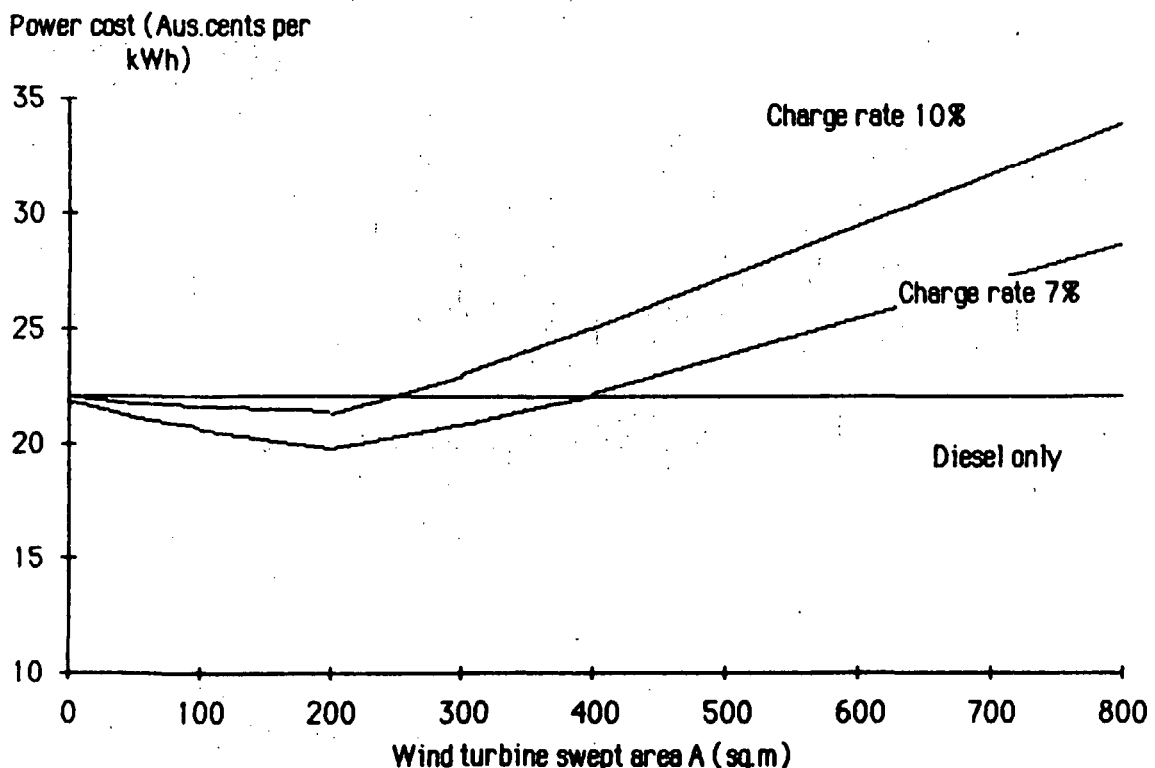

Figure 62. Energy costs for wind plus intermittently operated diesel system (no diurnal load pattern), for capital charge rates 10 and 7% p.a.

4.10 Fuel Cost

The fuel cost in the base-case was taken as 7 Aus. cents per kWh (fuel). The actual price in Sydney is presently (Jan. 1986) about 5 c/kWh(f) or 50 c/l, whereas the cost in remote areas such as Lord Howe Island is above 10 c/kWh(f) = 1 \$/l. The base-case is compared with $F = 5$ and $F = 10$ c/kWh(f) in Figure 63. The higher the fuel price, the more significant becomes the minimum that indicates an advantage in having a non-zero wind component in the system. At the lower fuel price, there is no significant change in price between $A = 0$ and $A = 200$ m², but at the higher fuel price, some 3 c/kWh or 10% of the total cost can be saved by introducing 200 m² of windswept turbine area for each 50 kW of average load or 100 kW of diesel generator.

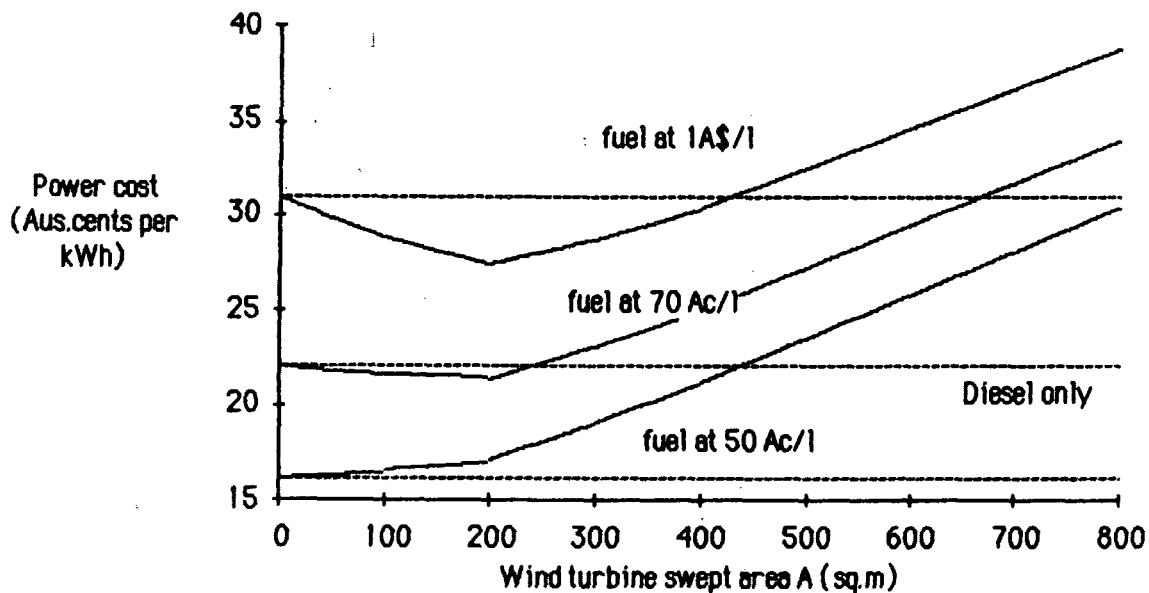

Figure 63. Energy costs for wind plus intermittently operated diesel system, for 3 different diesel fuel prices. All other parameters are kept at base value.

4.11 Wind Turbine Cost

Until now, it has been assumed that the wind turbine (and related) costs scale in direct proportion to the swept area. As discussed in Sorensen [1986, Figure 9], the current costs per square metre swept of commercial wind turbines exhibit a minimum near $A = 300$ m², with steeply rising costs per m² below 100², and uncertain but probably higher specific costs for large turbines.

Figure 64 tries to quantify these variations, based on actual costs for selected wind generators. The Danish and (one) Australian manufacturers seem to lie on the same curve (assuming domestic delivery), whereas the imported HMZ machine chosen for the Malabar site is above the main trend curve (its actual cost has been used, excluding import duty). All the costs shown include the wind turbine cost plus a flat 50% to cover site work plus the equipment and controls needed for interfacing with a diesel generator. Cost levels are ultimo 1985. The pitch control mechanism of

the HMZ machine as compared with the fixed pitch machines may account for some of the price difference, the rest presumably having to do with shipping and travel expenses for sales personnel and technical assistance during the running-in period.

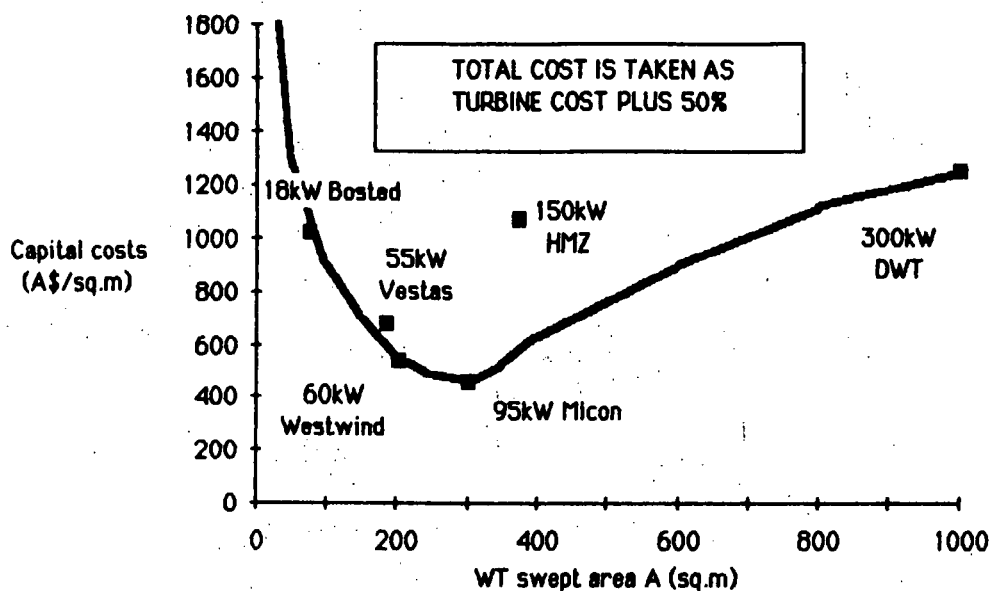

Figure 64. Specific cost (A\$/m² swept) of wind turbine and diesel interface equipment as function of area swept. Actual wind turbine prices have been used, plus a flat 50% to cover site and diesel combination expenses.

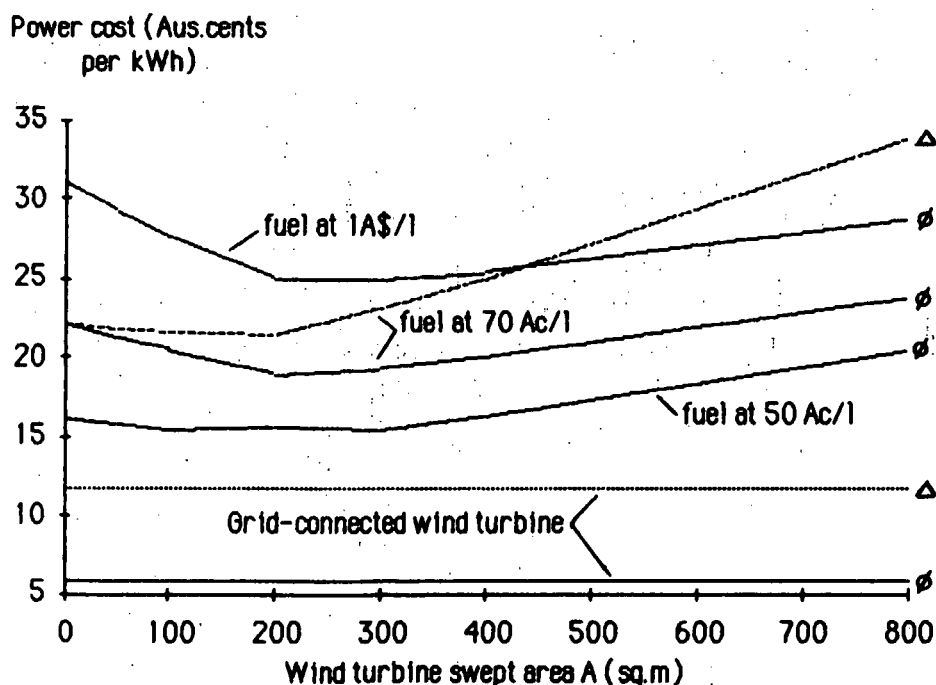

Figure 65. Energy costs for wind plus intermittently operated diesel system, for two different specific wind turbine costs (the base-case 900 A\$/m² marked Δ and alternatively 450 A\$/m² marked \emptyset). For the lower cost, the influence of raising or lowering the diesel fuel price is also illustrated.

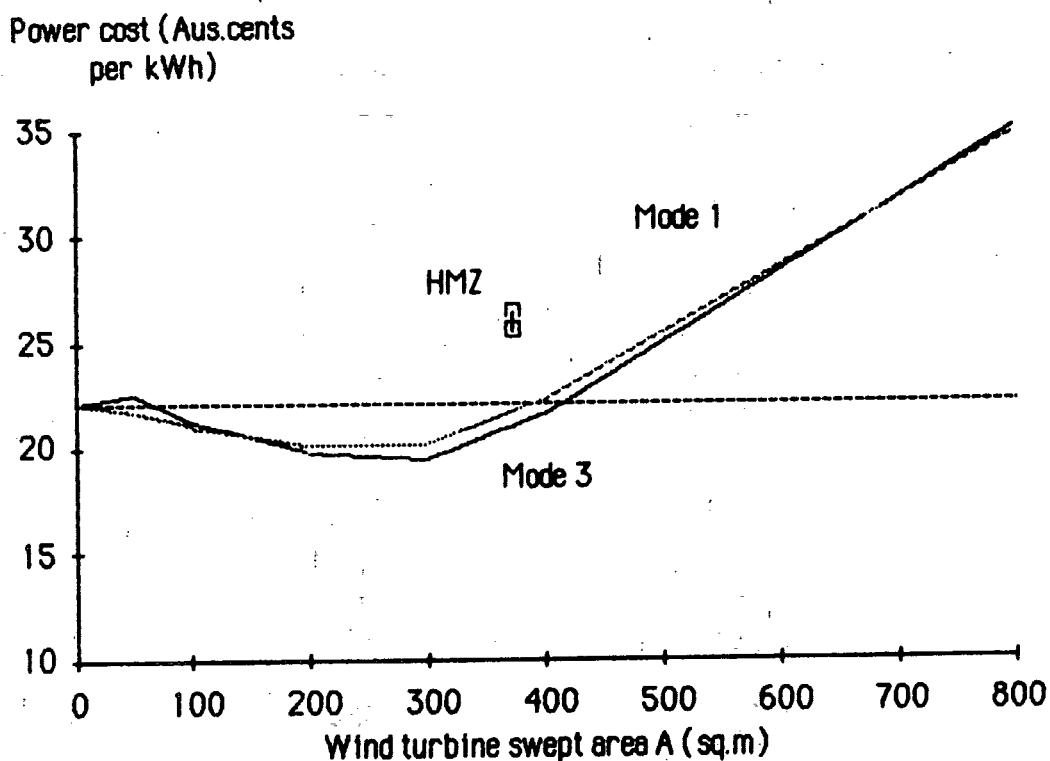

Figure 66. Energy costs for wind-diesel system using realistic wind turbine costs and assuming either continuous diesel operation (dashed curves) or on/off operation (full curves). Two trends for larger wind turbine swept areas are shown, corresponding to the two cost trends of Figure 64.

Figure 65 shows the effect of lowering the wind turbine and system costs from 900 A\$/m² to 450 A\$/m², corresponding to the minimum of Figure 64. The dependence on swept area changes, by deepening the cost gain relative to pure diesel operation, and by lessening the penalty of choosing a wind turbine swept area above the optimum value.

For Lord Howe Island fuel prices (1A\$/l), there is now a clear economic advantage of introducing the wind component into the system. For 200-400 m² swept area for each 50 kW average load, the energy cost is reduced by 5 cents per kWh or 16%. At a fuel price of 70 c/l there is a 14% saving, while at 50 c/l the saving is only 7% and the price is insensitive to wind turbine sizes in the range of 50 - 400 m².

In Figure 66, the variable cost curve of Figure 64 has been used to calculate total energy costs, for the 7 c/kWh(f) = 70 c/l fuel price. Again the economic optimum is clearly present, but relative to the base-case, its position has moved from 200 m² to about 300 m², but with essentially flat behaviour between these two values. The results are indicated both for continuous diesel operation (mode 1), and for diesel on/off operation (mode 3). In mode 1, the cost optimum has a total energy cost 10% below that of pure diesel operation, while for mode 3 operation, the saving is 12%.

One should note that Figure 64 gives actual costs, implying that the results of Figure 66 do not scale linearly with average load, as all the other cost figures have. If load is doubled from 50 kW to 100 kW, then the economically favourable wind turbine size does not change from 300 m² to 600 m². Rather, one should put in the 600 m² worth of wind power in the form of two 300 m² wind turbines.

Generally, the implication of the variable wind turbine cost model is that:

- (a) It is not economic to put in a wind turbine smaller than about 80 m² swept area, no matter what the load.
- (b) At present, larger amounts of wind power are best provided by multiple units with a swept area of 200 - 300 m² each.

4.12 Dependence on Wind Conditions

So far, all calculations have used the wind speed distribution data for the Malabar headland site, with an average wind speed of 6.7 m/s (this, by the way, may not be the long-term average, because of the short monitoring period - at other wind logging stations in the area, the period in question had winds below average). Furthermore, the shape of the distribution (Figure 48) is somewhat unusual, which may exert an influence on the wind-diesel model results.

The model was therefore re-run with a conventional Weibull wind distribution ($k = 1.85$, $c = 7.768$ m/s), chosen to give the same 6.7 m/s average as the actual Malabar distribution. The results shown in Figure 67 exhibit little difference; the conventional distributions gives a 0.6 c/kWh lower cost at the optimum. The total wind power production with the conventional Weibull distribution is 12% higher than with the Malabar distribution, although the average wind speeds are identical.

Changing the average wind speed (through the Weibull parameter c) has a significant influence on the total cost of wind-diesel power generation. The lower the average wind speed, the higher the cost. Some examples are added in Figure 67, for a 200m² wind turbine of fixed characteristics.

4.13 Sensitivity Analysis

A sensitivity analysis was performed by varying individual parameters and fixing the remaining at the value corresponding to the economic maximum for diesel on/off operation. The result is given in Figure 68. It includes the parameter changes discussed in the previous sections (wind turbine capital cost, swept area, fuel cost and average wind speed), plus a few additional ones.

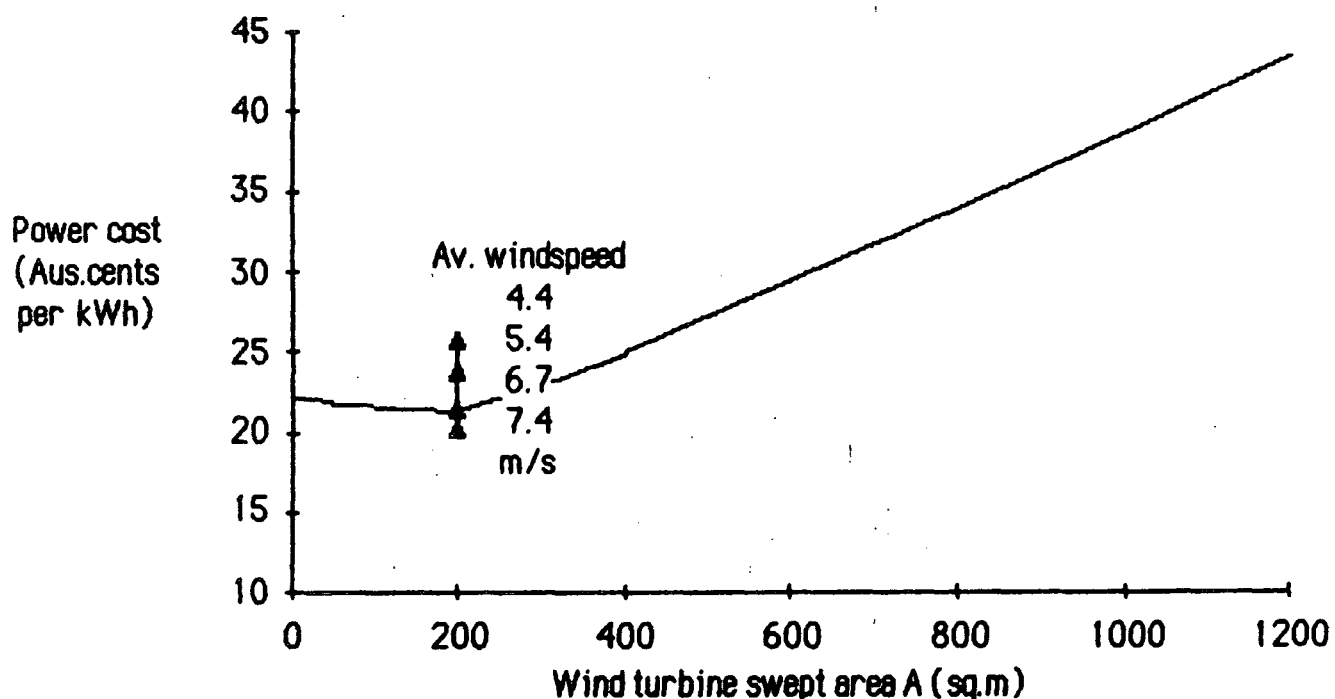

Figure 67. Comparison of wind-diesel model results using actual Malabar wind data or a standard Weibull distribution of $k = 1.85$. The values of c are given in Figure 71. The effect of varying the average wind speed is indicated (dots).

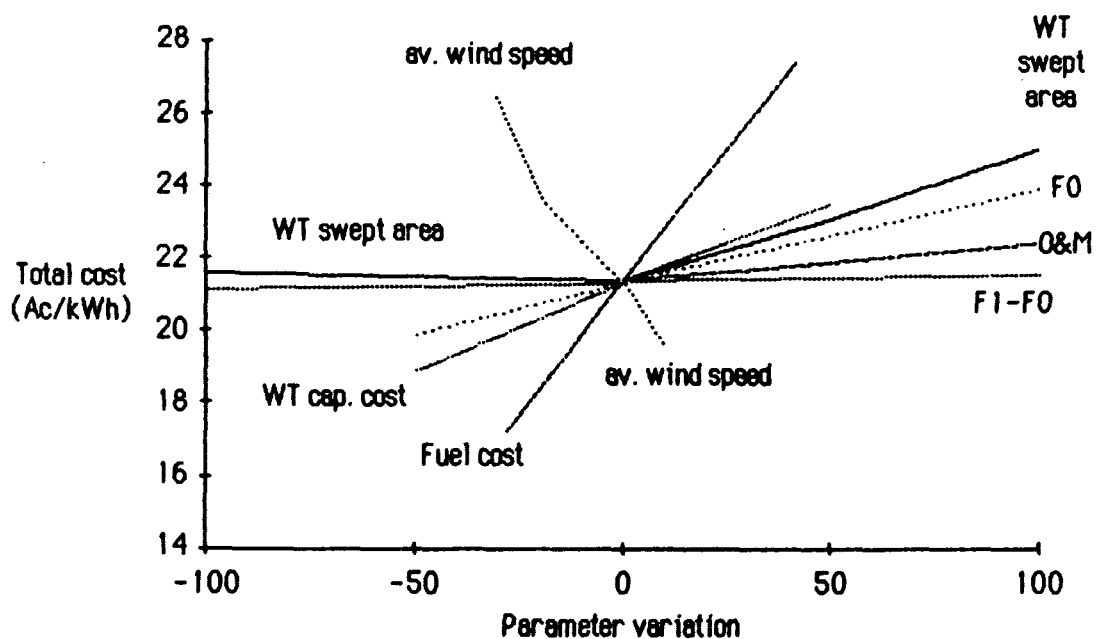

Figure 68. Spider diagram of the model's parameter sensitivity at the economic optimum point ($A = 200 \text{ m}^2$)

The extra cost for operation and maintenance of the diesel engine, when it is run at light load for prolonged periods, is not known with any precision, as discussed in Section 4.2 in connection with Figure 47. The sensitivity to the relevant parameter ($F1 - F0$) was checked over the range from zero to 5 times $F0$. The influence on cost was found to be linear, as shown in Figure 68.

If the overall operation and maintenance costs were doubled (from 2 to 4% p.a. of capital cost) the cost of power for the optimum wind turbine size would increase by nearly 4%, and the optimum would move from 200 to near 100 m² (for mode 3 operation). While the O & M costs for wind turbines are based on actual experience, they may well be higher for particular turbines. The O & M costs for diesel engines are certainly higher than 2% of capital costs annually for very small machines, whereas they may be lower for the larger engines operated by power utility companies. However, the diesel O & M costs do not in this model affect the optimisation of wind turbine size, because it is assumed constant (apart from the light loading penalty O & M, which is treated separately).

Figure 68 also shows the cost sensitivity to the idling fuel consumption, $F0$, which vary considerably from one engine to another. In varying $F0$, the slope of the fuel use curve (Figure 47) for power outputs between zero and $P0$ is changed, so that the light load extra fuel use goes proportionally down, if $F0$ is diminished. One way of realising a low value for $F0$ is to install two diesels, of which the smaller operates continuously. This means that a low choice of $F0$ to some extent models operation in mode 2 (see Table 1).

The power curve (a) (Figure 54) used for the base-case simulation and the variations discussed so far is not representing a close fit to the actual machine to be installed at Malabar. (it overshoots from 7-14 m/s and does not include the extra bump in the HMZ turbine output between 14 and 20 m/s). Using an alternative fit (power curve (b) in Figure 54), the results are somewhat changed due to the altered relative emphasis on lower and higher windspeeds. All windspeeds used in the present study are at hub height. Figure 69 gives the total energy cost for a wind-diesel system calculated with power curve (b), for realistic wind turbine prices and operation in mode 1 or 3. As before (Figure 66), the optimum is at 300 m² for a 50 kW load, but the optimum is more shallow. The reason for this can be seen in Figure 70, which gives the calculated frequency distribution of wind power relative to rated power. The power curve (b) generator is at or near a standstill during 63% of the year, for 1984 Malabar wind conditions, and produces the rated power for only 6% of the time. The corresponding figures using power curve (a) are 51% and 11% of time. These sets of figures are not completely comparable, though, because the effective rated power of curve (b) in Figure 54 is 167 kW and not 150 kW, so that the sorting intervals for the time-distributions are not the same.

The total wind power production using power curve (b) is only 76% of the one obtained with power curve (a). As wind conditions for typical years may on the other hand be better than assumed in the model calculations, the base-case (power curve (a)) may still give a fair representation of actual wind power production at Malabar.

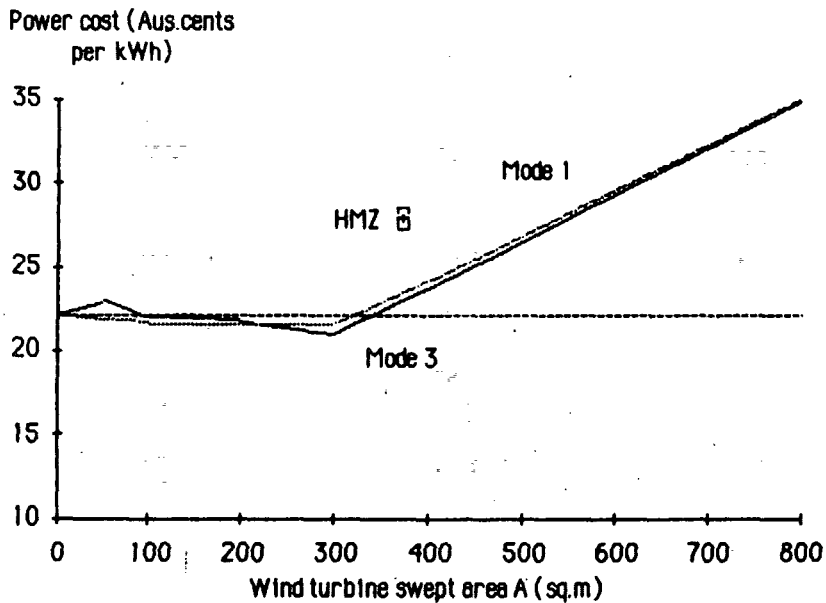

Figure 69. Calculated energy cost for wind-diesel system using realistic wind turbine costs and power curve (b) of Figure 54. Mode 1 operation (dashed line) or mode 3 operation (full line).

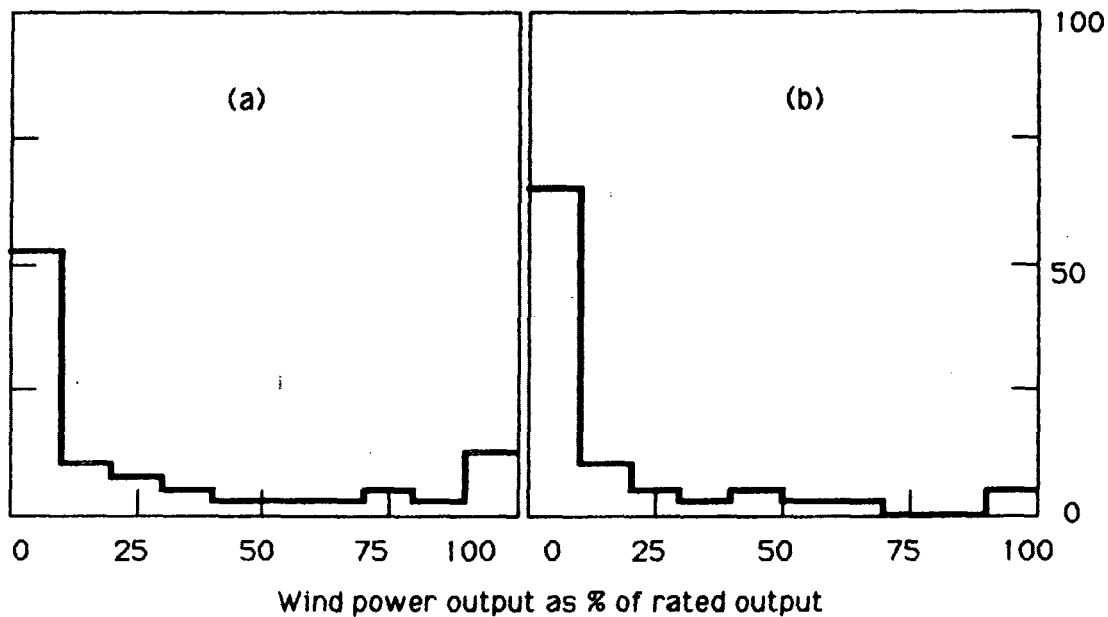

Figure 70. Time-distribution of wind turbine output, using power curves (a) or (b).

4.14 Frequency Distributions

Additional insights into the effect of adding increasing amounts of wind power to a diesel power system may be gained from the temporal frequency distributions of quantities such as wind and diesel power output, and variable costs. These distributions show the fractions of time (say a year), during which the power levels and variable costs were within certain intervals. The variable costs are in the present model only fuel costs and extra O & M costs when running the diesel at low loads. All other costs are time-independent.

Figure 70 (a) showed the time-distribution of wind power output for the base-case calculation using Malabar wind data. Figure 71 shows how this distribution depends on wind conditions, using the four standard Weibull distributions of increasing average windspeed described in Section 4.12.

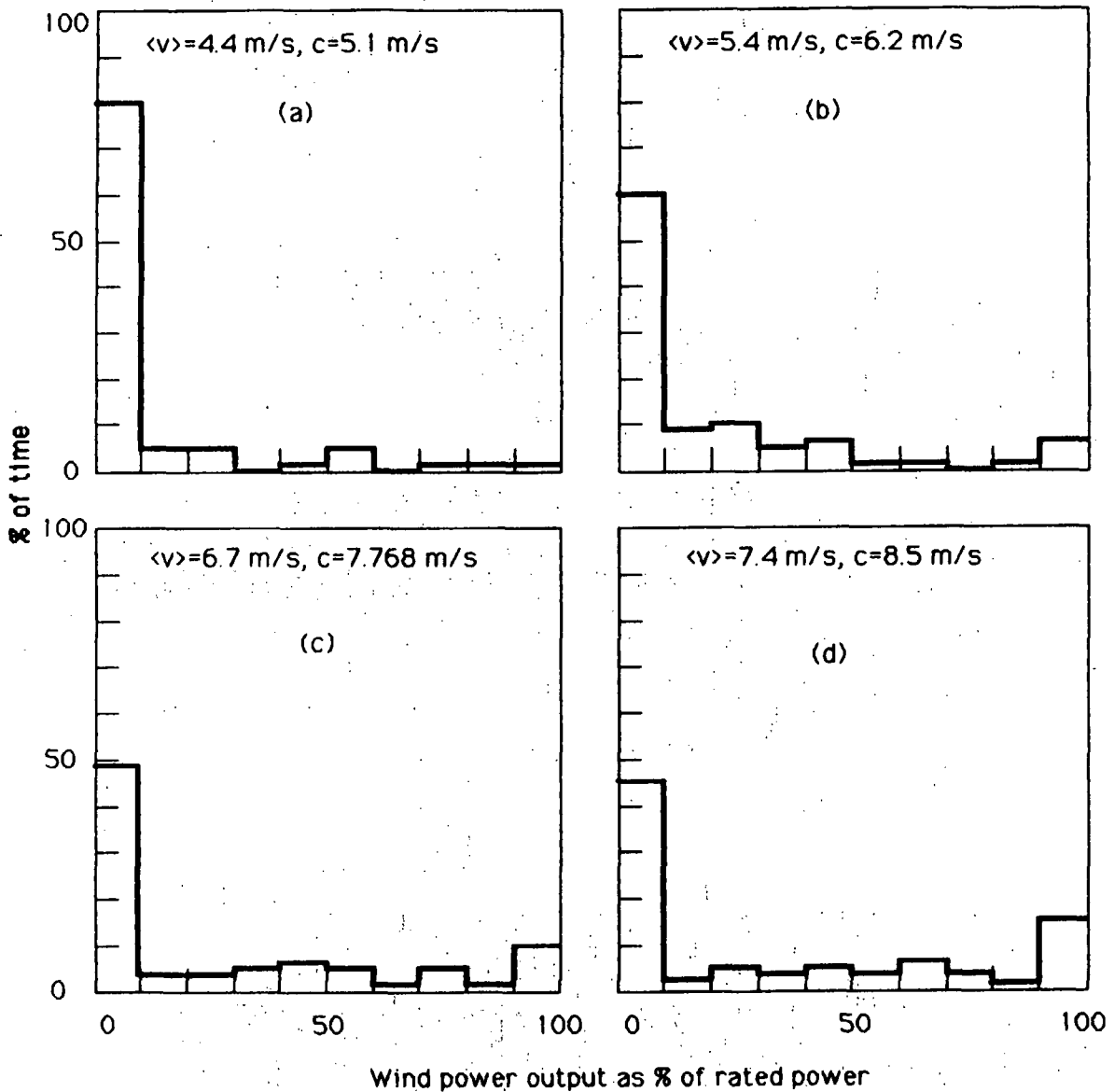

Figure 71. Time-distribution of wind turbine output for different average windspeed regimes, using $k = 1.85$ Weibull distributions.

Figure 72 shows the time-distribution of diesel loading, as function of wind turbine swept area. It is seen how the light loading problem becomes more and more severe, as the wind component increases.

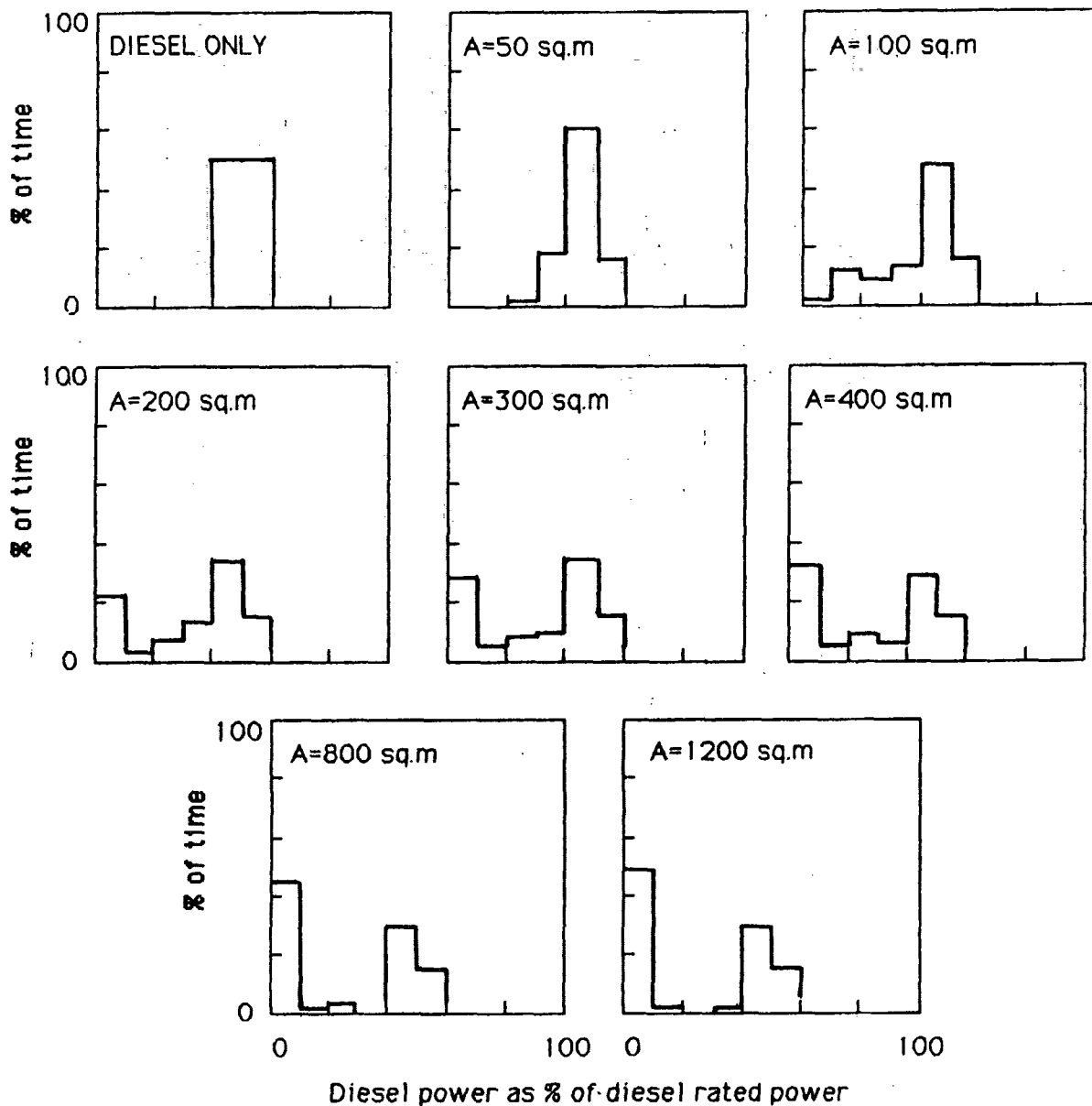

Figure 72. Time-distribution of diesel output, for base-case mode 3 operation (intermittent diesel) of wind-diesel system with different sizes of wind turbines. The diurnal load variations were suppressed in this calculation.

In Figure 73, the time-distribution of variable costs are given as a function of wind turbine swept area, for diesel on/off operation. Below $A = 200 \text{ m}^2$, the diesel is never off, but above this turbine size, the variable costs go to zero for a certain fraction of time, indicating that

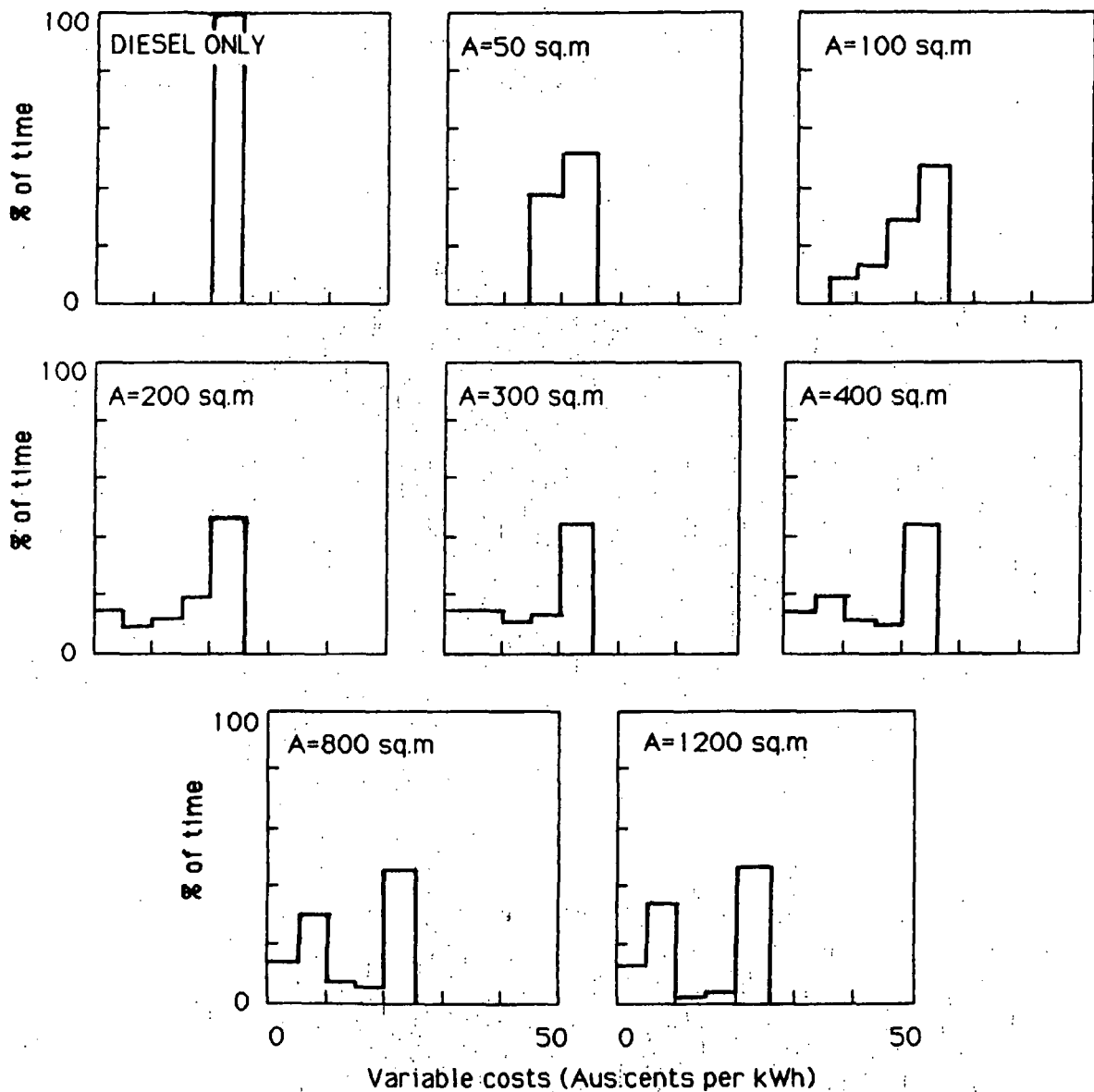

Figure 73. Time-distribution of variable costs, for base-case mode 3 operation (intermittent diesel) of wind-diesel system with different sizes of wind turbines.

the wind turbine is then operating alone. The secondary peak at 5-10 cents per kWh, which develops for large wind turbine size, reflects situations where the wind turbine could have covered the load, but where the conditions (see Section 4.6) for turning the diesel off could not both be satisfied.

4.15 Placing International Experience in the Model Context

Some of the international projects described in Chapter 2 have been placed in the context of the base-case model calculation in Figure 74 (superimposing the results from Figures 56 and 57) by scaling the wind turbine swept area so that the average service load equals 50 kW.

The Rottneast and Block Islands installations have the smallest wind turbine swept area to average load ratio A/LA . The behaviour of these systems should approach that of grid-connected wind turbines on a large grid, provided that suitably rated diesel engines are available and properly dispatched. The Block Island wind power production falls short of the base-case calculation, due to inferior wind conditions, and the fuel saving is correspondingly reduced.

The same is true for the Sudbury installation (average wind speed 5.4 m/s), whereas the Kythnos system produces the same amount of wind power as the model, but less fuel saving. This system happens to lie at the value of $A/LA = 4 \text{ m}^2/\text{kW}$, which according to the model calculation is the optimum. In this A/LA region, the wind power production is a considerable fraction of the load (here about 40%), implying that the wind turbine no longer behaves like negative load on a large grid (cf. the remarks in Section 2.1.5).

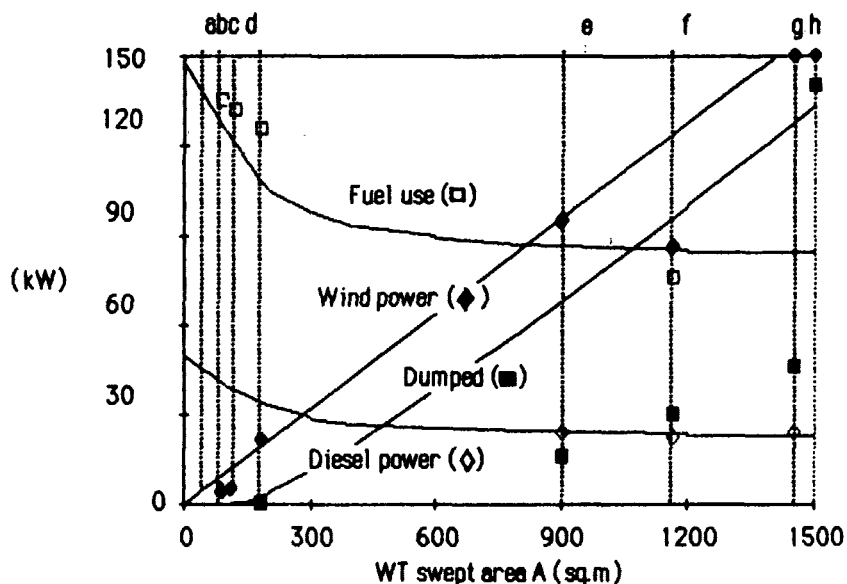

Figure 74. Comparison of model calculation wind power production (◆), diesel production (◇), power dumped (■) and fuel used (□), with actual wind-diesel systems: a = Rottneast Is., b = Block Is., c = Sudbury, d = Kythnos, e = Fair Is., f = Dutch Test Site, g = Lundy Is. and h = Inis Oirr (g and h are not to scale, because the average load figure is not available).

The Inis Oirr and Dutch Test Site systems have wind component far above the optimum A/LA value. In the Dutch case, the adverse effects of this situation do not fully materialise, due to the oversizing of the diesel relative to average load (5:1). Still, the small amount of power dumped is surprising and may reflect peculiar correlations between the time-variation of wind power and load.

Finally, the Fair and Lundy Island systems are special cases, where the A/LA ratio is high if LA represents only time-urgent loads, but where a large portion of the dump power has been diverted to useful purposes. Generally speaking, a search for possible uses of wind-produced power that would otherwise have to be dumped should always be made, as it may greatly improve the economy of the project.

4.16 Discussion of the Results and their Implications for NSW Projects

The main conclusions from the model calculations presented in this Chapter are that:

- (i) At locations where windspeeds exceed 6 m/s and the diesel fuel price is about 1A\$ per litre or more, the installation of 4-6 m² of wind turbine swept area per kW of average load, and setting up for a system with intermittent diesel operation, could produce monetary savings in excess of 10% compared with diesel only. At windspeeds between 5 and 6 m/s, only wind turbines costing 300A\$ per m² swept area or less should be considered.
- (ii) At locations where windspeeds exceed 6 m/s and the diesel fuel price is around 70 cents per litre, the installation of imported wind turbines does not appear economically viable, but Australian produced wind turbines costing about 300 A\$ per m² swept area (not including site and diesel interfacing costs) could produce monetary savings in excess of 10%, assuming intermittent diesel operation and 4-6 m² swept area per kW of average load.
- (iii) At locations where the diesel fuel price is 50 cents per litre or below, no distinct economic advantage can be derived from adding wind turbines.

The conclusions above are based on a capital charge rate of 10%. If a lower value were used, the advantage of wind-diesel combinations would improve.

If the diesel engines are not allowed to operate in the on/off mode, the savings will be reduced by up to a third, and the optimum wind share may be reduced.

Technical problems to be resolved before extensive dissemination of wind-diesel systems will be discussed in Chapter 5.

In those cases where winds are adequate (6 m/s or higher average speed), but economic savings not expected, it could be contemplated to install wind-diesel systems for non-economic reasons, such as the decreased dependence on fuel prices on the international market, or environmental considerations. The reason for these options is, that the cost of energy from a wind-diesel system is fairly independent of whether the diesel is operated alone or if up to around 6 m² of wind turbine swept area per kW average load is added, even if the fuel price and wind turbine cost do not ensure any direct saving.

Apart from the swept area to average load condition, the wind turbines should preferably be in units of 200 - 300 m² swept area, if the predicted savings are to materialise with current wind turbine pricing.

5. SUGGESTED EXPERIMENTS FOR THE MALABAR INSTALLATION

5.1 Phase 1: Grid-connected Wind Turbine

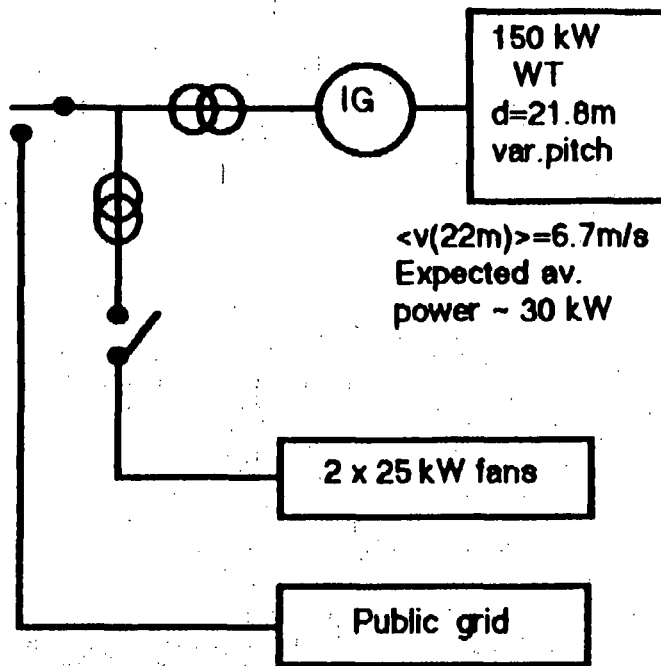

Figure 75

Apart from standard break-in procedures, experiments to perform during this phase may include:

- (1) Simultaneous measurements of wind-speed on meteorological mast and turbine electric power output, in order to establish a practical power curve for the machine.
- (2) Recording of minimum/maximum wind speeds and turbine power output as related to (ten minute) averages.
- (3) Monitoring the pitch control performance (interval between changes, speed of changes, etc.).
- (4) Studying the computer control software and assessing its adaptability for alternate control strategies (e.g. of pitch angle) and for use with wind-diesel system in different modes of operation.
- (5) Check turbine's and generator's gusting response.
- (6) Measure noise and TV interference effects.
- (7) Measure grid voltage profiles and check reactive power requirements.

5.2 Phase 2: Wind Turbine Operated in Conjunction with Continuously Running Gas Generator

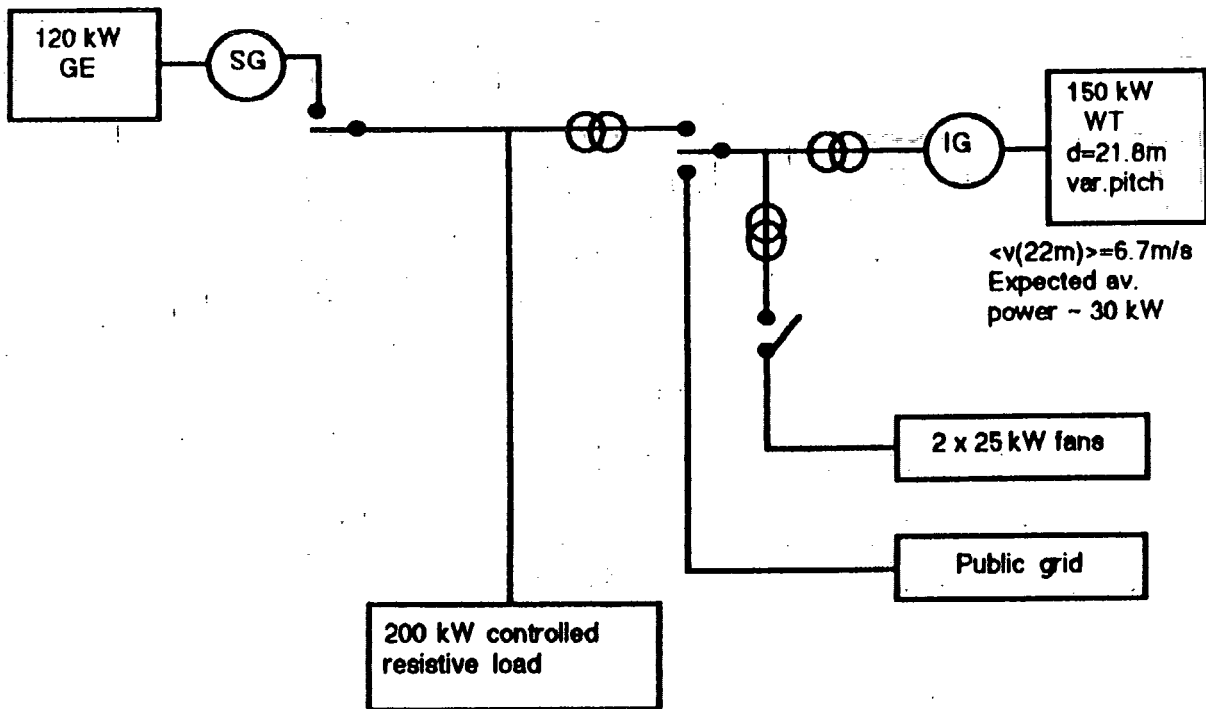

Figure 76

- (1) Study behaviour of control system.
- (2) Establish gas engine fuel consumption curve. The fuel efficiency of this type of gas engine is not as good as for some diesel engines (cf. Figure 47).
- (3) Measure frequency and voltage behaviour, transients, real and reactive power flows.
- (4) Measure fuel savings and power production by wind and gas, for different imposed load patterns, including time-distribution of part load for the gas engine.
- (5) Check for gas engine operation and maintenance problems arising from light load running. If any problems are found, try to eliminate them through improved control strategy (eg. occasional heavy load running - or as a last resort by shutting the wind machine down when gas engine loading drops below some prescribed minimum).

5.3. Phase 3: Diesel Engine Added to System

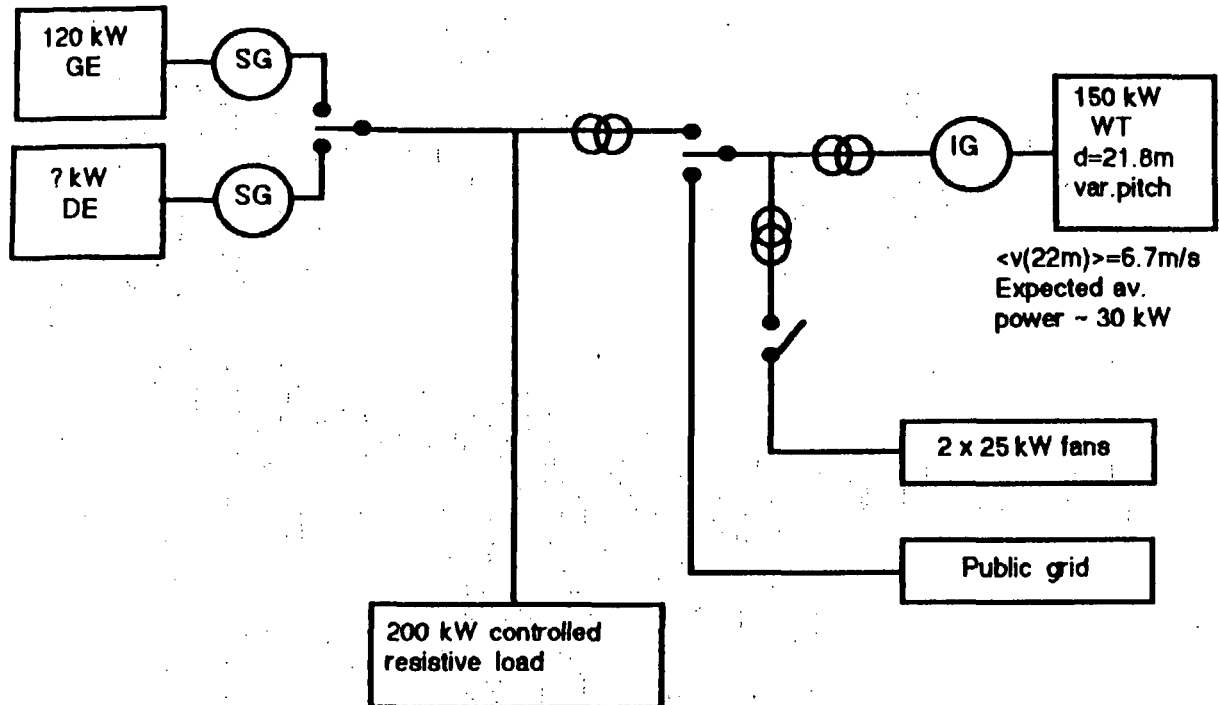

Figure 77.

- (1) Repeat the most interesting Phase 2 tests with the diesel engine replacing the gas engine, in order to establish similarities and differences.
- (2) Operate both diesel and gas engine, but one (the smaller if ratings differ) continuously and the other on/off. Perform checks as above.

5.4 Phase 4: Wind Turbine Operated in Conjunction with Intermittently Running Gas or Diesel Generator

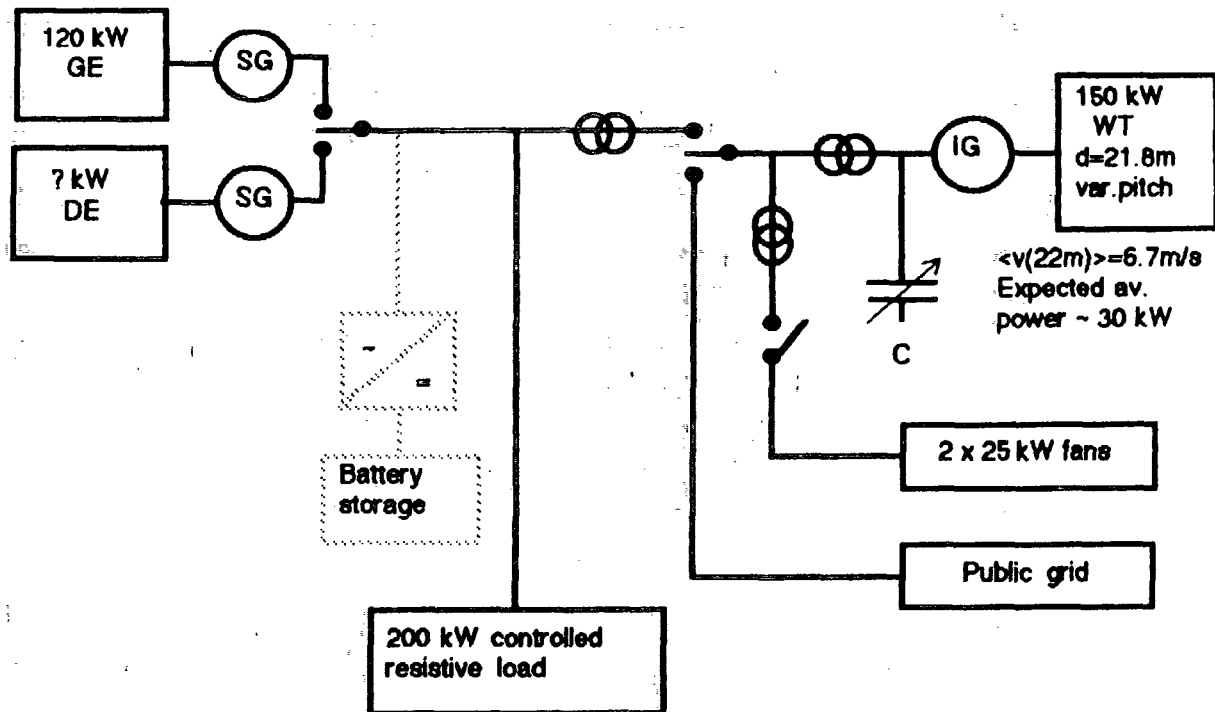

Figure 78.

A capacitor bank is assumed installed, a battery store perhaps added later.

- (1) Monitor gas or diesel engine stops/starts as function of control strategy.
- (2) Record general power behaviour (as in Phase 2), and possible loss-of-power situations in connection with gas or diesel engine on/off switching.
- (3) Check if on/off operation changes the situation as regards potential light load problems.
- (4) If a battery facility is installed, re-check power behaviour during switching, and monitor battery discharge rates and possibly establish rate of degrading.

5.5 Supporting Theoretical Studies

- (1) Determine the most appropriate size for the diesel engine (before acquiring the diesel set)
- (2) Assess experiments using short-term and average-behaviour models (existing or new ones).
- (3) Report characteristics of meteorological measurements, when sufficient data are accumulated (min. one year).

APPENDIX 1

The simulation program (SHARP - 1260 BASIC) used for the calculations in Chapter 4 with sample run.

```

1:REM *BENT SØRENSEN*
      11FEB86
2:REM -----
3:REM INITIALISATION
4:REM -----
5:DIM C(10),L(10),W(10),D(10),C$(1)*24
10:"M": WAIT 200: FOR I
   =0 TO 10:C(I)=0:L(I)
   =0:W(I)=0:D(I)=0:
   NEXT I
20:PRINT "WIND/DIESEL C
   OMBINATION MALABAR C
   ASE VERSION 4":AM=
   373:M0=4:IM=7
30:WAIT 0:LL=0:DD=0:FF=
   0:TC=0:WW=0:SM=5.000
   1:CA=2
40:SW=9.82:SD=7:V0=5.5:
   V1=12:RD=100:F0=.4*R
   D:P0=.7*RD:G=.37:D0=
   1.2:D1=.8
50:R= RND 0:K2=2.5:K3=1
   .8:C0=1:C1=0:C2=6:C3
   =10:A1=.00:H0=12:H1=
   21:M0=12:H=1
60:DU=0:HS=0:VV=0:K0=1.
   /K2:K1=1./K3:V0=(-
   LN (1-R))^K0
65:L0=50:L1=10:L2=.5:L3
   =1.5:M1=1:DS=0:F1=.5
   *RD:P1=.4*RD:F=0:FC=
   0:DX=.001
70:GOSUB 1500:RW=.402*A
   W
80:Y2=C0+C1* COS (R*(M0
   -M0)/6):V0=V0*Y2*C2
90:Y1=L0+L1* COS (R*(M0
   -M1)/6):LM=(L0+L1)*L
   3:LA=L0*(.5+(L2+L3)/
   2)
95:GOSUB 500
97:REM -----
98:REM MAIN LOOP
99:REM -----
100:FOR I1=1 TO IM: FOR
   I=1 TO 24
110:R= RND 0: IF I>H0-1
   AND I<H1 THEN 120
115:X=C2*Y2*(- LN (1-R))
   ^K0: GOTO 130
120:X=C3*Y2*(- LN (1-R))
   ^K1
130:V=A1*V0+(1-A1)*X:VV=
   VV+V
140:R= RND 0: IF I>18
   THEN LET LL=Y1*(L3+.
   2*(R-.5))
150:IF I<7 THEN LET LL=Y
   1*(L2+.2*(R-.5))
160:IF I>6 AND I<19 THEN
   LET LL=Y1*(1+.2*(R-.
   5))
170:L(0)=L(0)+LL:X=LL/RD
   *9.9999:J= INT (X)+1
   :L(J)=L(J)+1
180:FC=0: IF V<=V0 THEN
   LET WW=0
190:IF V>V0 THEN LET WW
   =RW
200:IF V>V0 AND V<V1
   THEN LET WW=RW*(V-V0
   )/(V1-V0)
210:J= INT (WW/RW*9.9999
   )+1:N(J)=W(J)+1:X=LL
   -WW:W(0)=W(0)+WW:V0=
   V
215:IF CA<>2 THEN 230
220:IF WW/LL>D0 AND WW/R
   W>D1 THEN 350
221:REM ***DIESEL ON/OFF
   F***
230:IF X>RD THEN BEEP 3
240:IF X>P0 THEN LET F=
   X/G
250:IF X>0 AND X<P0 THEN
   LET F=F0+(P0/G-F0)/P
   0*X
260:IF X>=P1 THEN LET FC
   =F*SD
270:Y=F0+(P0/G-F0)/P0*P1
   : IF X>0 AND X<P1
   THEN LET FC=(Y-(Y-F1
   )*(P1-X)/P1)*SD
280:IF X<=0 THEN LET F=F
   0
290:IF X<=0 THEN LET FC=
   F1*SD
300:IF X>0 THEN LET DD=D
   D+X
310:IF DX=0 AND X>0 THEN
   LET DS=DS+1
320:IF X>0 THEN LET DX=X
330:IF X>0 THEN LET D(0)
   =D(0)+X
340:FF=FF+F:TC=TC+FC:
   GOTO 360
350:IF CA<>2 THEN 360
351:DX=0:HS=HS+1
352:REM ***DIESEL ON/OFF
   F***
360:IF X<0 THEN LET DU=D
   U-X
370:J= INT (FC/LL/SM)+1:
   IF J>10 THEN LET J=1
   0
380:C(J)=C(J)+1
390:J= INT (X/RD*9.9999)
   +1: IF J<1 THEN LET
   J=1
400:D(J)=D(J)+1: IF 00=0
   THEN 470
410:REM DISPLAY-----
430:CLS :X=LL: GOSUB 210
   0: PRINT "LOAD-WIND-
   FUEL-COST":
435:PRINT STR$(I):"H:";
   : CURSOR 24: PRINT A
   $;" ";
440:X=WW: GOSUB 2100:
   PRINT A$;" ";
450:X=F: GOSUB 2100:
   PRINT A$:"KWH";
460:X=FC/LL: GOSUB 2100:
   PRINT A$:"C/KWH";
470:IF H0=1 THEN GOSUB 9
   20
480:NEXT I
490:NEXT I1: GOTO 950
495:REM DATA PRINT-----
496:REM SUBROUTINE-----
500:C$(0)="DO YOU WANT T
   O PRINT ": CLS :
   PRINT C$(0):"BASIC D
   ATA";
510:GOSUB 2000: CLS : IF
   A$(0)"Y" THEN RETURN
600:PRINT "PRESS A (ALL)
   - ANY OTHER (PA
   RTIAL OUTPUT)";
610:GOSUB 2000:X=1: IF A
   $="A" THEN LET X=0

```

```

620:LPRINT : LPRINT "WIN
D/DIESEL COMBINATION
": LPRINT "MALABAR C
ASE - VERSION 4"
630:LPRINT "MONTH=";MO:
LPRINT
640:IF X=0 THEN 670
650:C$(0)="DO YOU WANT T
O PRINT ": CLS :
PRINT C$(0);"BASIC D
ATA";
660:GOSUB 2000: IF A$<>"
Y" THEN 890
670:LPRINT "BASIC DATA,
WIND:" USING "#####
.#"
680:C$(0)="WIND TURBINE
RATING:" : GOSUB 2200
: GOSUB 2250:M=14:
GOSUB 2300: LPRINT R
H;" KW"
685:C$(0)="CUT-IN SPEED:
": GOSUB 2200:
LPRINT V0;" M/S"
690:C$(0)="FULL POWER SP
EED:" : GOSUB 2200:
GOSUB 2250:M=13:
GOSUB 2300: LPRINT V
1;" M/S"
695:C$(0)="CAPITAL COST
OF ": GOSUB 2200:
LPRINT "WT & DE"
696:C$(0)="+ FIXED ":
GOSUB 2200: LPRINT "
O&M";SH;" C/KWH";
700:LPRINT "W";:C$(0)="E
IBULL PARAMETERS:" :
GOSUB 2200: GOSUB 22
50
701:LPRINT " K2=";K2:
LPRINT " K3=";K3
705:LPRINT " C0=";C0:
LPRINT " C1=";C1:
LPRINT " C2=";C2;"
M/S": LPRINT " C3="
;C3;" M/S"
710:USING "###.###":C$(0)
)="AUTOCORR.COEF.
": GOSUB 2200:
LPRINT A1
715:USING "#####":C$(0)="
PEAK MONTH:" : GOSUB
2200: LPRINT M0
720:C$(0)="PEAK HOUR: ":
GOSUB 2200: LPRINT H
0
725:LPRINT : LPRINT "BAS
IC DATA, DIESEL:" :
USING "#####.#"
730:C$(0)="DIESEL RATING
": : GOSUB 2200:
LPRINT RD;" KW"
735:C$(0)="FUEL USE IDLI
NG:" : GOSUB 2200:
GOSUB 2250
736:C$(0)=" (HEAT VALUE)
": GOSUB 2200:
LPRINT F0;" KW"
740:C$(0)="FUEL PROPORTI
ONALITY": GOSUB 2200
: GOSUB 2250
741:C$(0)=" FROM
": GOSUB 2200:
LPRINT P0;" KW"
745:C$(0)="CONVERSION EF
FICIENCY:" : GOSUB 22
00: GOSUB 2250:M=18:
GOSUB 2300: LPRINT
USING "###.##";G
750:C$(0)="DIESEL SHUT D
OWN CRIT.": : GOSUB 2
200: GOSUB 2250
755:C$(0)=" WIND POWER/L
OAD > ": GOSUB 2200:
LPRINT USING "##.##"
;D0
760:C$(0)=" WIND POWER/R
ATED >": GOSUB 2200:
LPRINT USING "##.##"
;D1
764:C$(0)="FUEL COST: ":
GOSUB 2200: GOSUB 22
50
765:LPRINT USING "#####.#
";SD;" C/KWH";C$(0)
)="(HEAT VALUE)":
GOSUB 2200: GOSUB 22
50
766:C$(0)="EXTRA O&M BEL
OW": GOSUB 2200:
LPRINT USING "#####
";PI;" KW"
767:C$(0)="RISING AT ZER
O LOAD TO": GOSUB 22
00: GOSUB 2250
768:M=10: GOSUB 2300:
LPRINT USING "#####.
#";(F1-F0)*SD;" C/HO
UR"
770:LPRINT : LPRINT "BAS
IC DATA, LOAD:" :
USING "#####.#"
775:C$(0)="DISTRIBUTION
PARAMERERS:" : GOSUB
2200
780:LPRINT " L0=";L0;"
KW": LPRINT " L1=";
L1;" KW": LPRINT "
L2=";L2: LPRINT " L
3=";L3
785:USING "#####":C$(0)="
PEAK MONTH:" : GOSUB
2200: LPRINT M1
890:C$(0)="DO YOU WANT T
O PRINT ": CLS :
PRINT C$(0);"HOURLY
SIMUL. RESULTS";
895:GOSUB 2000:HO=1: IF
A$<>"Y" THEN LET HO=
0
896:IF HO=0 THEN RETURN
900:LPRINT : LPRINT "SIM
ULATION RESULTS:"
905:C$(0)="HOUR LOAD WIN
D FUEL COST": GOSUB
2200
910:C$(0)=" KW KW
KW C/KWH": GOSUB
2200
915:RETURN
920:LPRINT USING "###";I
;: LPRINT USING "###
##";LL;HW;F;FC/LL
930:RETURN
940:REM MAIN PRINT STEP
941:REM -----
950:LPRINT : LPRINT
USING "#####";24*MI;
" HOURS SUMMARY:"
955:C$(0)="ACC. LOAD:
": GOSUB 2200:
LPRINT USING "#####
";L(0);" KWH"
956:C$(0)="AV. WINDSPEED
": GOSUB 2200:
LPRINT USING "#####.
#";VV/24/MI;" M/S"
960:C$(0)="WIND POWER:
": GOSUB 2200:
LPRINT USING "#####
";W(0);" KWH"
961:C$(0)="DIESEL POWER:
": GOSUB 2200:
LPRINT USING "#####
";D(0);" KWH"
965:C$(0)="FUEL USED:
": GOSUB 2200:
LPRINT USING "#####
";FF;" KWH"
970:C$(0)="POWER DUMPED:
": GOSUB 2200:
LPRINT USING "#####
";DU;" KWH"

```

```

971:C$(0)="DIESEL STARTS
   ": GOSUB 2200:
   LPRINT USING "####";
   DS
975:C$(0)="DIESEL STOPPE
D": GOSUB 2200:
   LPRINT USING "####";
   HS;" HOURS"
980:C$(0)="AV. COST: ":
   GOSUB 2200: LPRINT
   USING "####.##";SW+T
   C/L(0);" C/KWH"
1000:LPRINT : LPRINT "D
   ISTRIBUTION CURVES
   "
1010:C$(0)=" LOAD DIE
   SEL WIND COST":
   GOSUB 2200
1020:FOR J=1 TO 10:L(J)
   = INT (L(J)/.24/IM
   ):D(J)= INT (D(J)/
   .24/IM)
1030:W(J)= INT (W(J)/.2
   4/IM):C(J)= INT (C
   (J)/.24/IM)
1040:LPRINT USING "###"
   ;10*(J-1): LPRINT
   USING "#####";L(J)
   ;D(J);W(J);C(J)
1045:NEXT J
1050:C$(0)="(% OF D OR
   W RATED POWER":
   GOSUB 2200: LPRINT
   "EXCEPT"
1060:C$(0)=" VARIABLE C
   OST WHICH IS":
   GOSUB 2200: GOSUB
   2250
1070:C$(0)="RELATIVE TO
   ": GOSUB 2200:X=1
   0*SM: GOSUB 2100:
   LPRINT A$;" C/KWH"
   "
1080:END
1490:REM KEY-DATA CHOIC
   E
1491:REM SUBROUTINE---
   ---
1500:WAIT 200: PRINT "I
   NPUT C FOR CHANGE
   ANY OTHER: NO
   CHANGE"
1510:WAIT 1: PRINT "DAY
   S OF SIMULATION: ";
   IM: GOSUB 2000
1520:IF A$(<)"C" THEN 15
   40
1530:INPUT " ->";IM:
   CLS : GOTO 1510
1540:CLS : PRINT "WT SW
   EPT AREA (M^2);AW
   "; GOSUB 2000
1550:IF A$(<)"C" THEN 15
   70
1560:INPUT " ->";AW:
   CLS : GOTO 1540
1570:CLS : PRINT "MONTH
   # ";MO: GOSUB 20
   00
1580:IF A$(<)"C" THEN 16
   00
1590:INPUT " ->";MO:
   CLS : GOTO 1570
1600:CLS : PRINT "FIXED
   CHARGE(C/KWH);SW
   "; GOSUB 2000
1610:IF A$(<)"C" THEN 16
   30
1620:INPUT " ->";SW:
   CLS : GOTO 1600
1630:CLS : PRINT "AUTOC
   ORR.COEF. ";
   AI: GOSUB 2000
1640:IF A$(<)"C" THEN 16
   60
1650:INPUT " ->";AI:
   CLS : GOTO 1630
1660:CLS : PRINT "0=D.0
   NLY, 1=W/D.CONT,
   2=W/D.INT: CASE
   ="ICA: GOSUB 2000
1670:IF A$(<)"C" THEN 16
   90
1680:INPUT " ->";ICA:
   CLS : GOTO 1660
1690:CLS : PRINT "DO YO
   U WANT RANDOM SEED
   FOR WIND?(<Y/N)";:
   GOSUB 2000
1700:IF A$="Y" THEN
   RANDOM
1710:IF CA=0 THEN LET V
   0=50
1720:IF CA=0 THEN LET V
   1=51
1730:CLS : PRINT "DO YO
   U WANT HOURLY OUTP
   UT ON DISPLAY?";:
   GOSUB 2000
1740:00=0: IF A$="Y"
   THEN LET 00=1
1750:CLS
1760:INPUT "RUN-ID ";C$
   (0): LPRINT "RUN:"
   ;C$(0)
1770:LPRINT "WT SWEPT A
   REA=";: LPRINT
   USING "#####";AW:
   " M2"
1780:LPRINT "MONTH=
   ";: LPRINT
   USING "#####";MO
1790:LPRINT "FIXED CHRG
   ES";: LPRINT USING
   "###.##";SW;" C/KW
   H"
1800:LPRINT "AUTOCORR.C
   OEF.": LPRINT
   USING "##.##";AI
1810:LPRINT "CASE # ";:
   LPRINT USING "###"
   ;CA
1850:RETURN
1990:REM -----
   -----
1991:REM SUBROUTINES
1992:REM -----
   -----
2000:A$= INKEY$ : IF A$
   =" " THEN 2000
2010:RETURN
2100:Y= INT (X+.5):A$=
   STR$(Y):N= LEN (A
   $): IF N>2 THEN
   GOTO 2120
2110:FOR N1=N+1 TO 3:A$
   =" "+A$: NEXT N1
2120:RETURN
2200:J= LEN (C$(0)):C$(
   1)="": FOR J1=1 TO
   J
2210:D$= MID$(C$(0),J1
   ,1):Y= ASC (D$):
   IF Y>64 AND Y<91
   THEN LET Y=Y+32
2220:C$(1)=C$(1)+ CHR$(
   Y): NEXT J1
2230:LPRINT C$(1)::
   RETURN
2250:LPRINT " ": RETURN
2300:C$(0)="": FOR J=1
   TO M:C$(0)=C$(0)+
   " ": NEXT J
2310:LPRINT C$(0)::
   RETURN

```

RUN:: SAMPLE RUN
 WT SWEEP AREA= 373 M2
 MONTH= 4
 FIXED CHRGES 10.00 C/KWH
 AUTOCORR.COEF. 0.70
 CASE # 2

WIND/DIESEL COMBINATION
 MALABAR CASE - VERSION 4
 MONTH= 4

BASIC DATA, WIND:
 wind turbine ratings:
 167.1 KW
 cut-in speed: 6.0 M/S
 full power speed:
 15.3 M/S
 capital cost of WT & DE
 + fixed O&M 10.0 C/KWH
 Weibull parameters:
 K2= 2.5
 K3= 1.8
 C0= 1.0
 C1= 0.0
 C2= 6.0 M/S
 C3= 10.0 M/S
 autocorr.coef. 0.700
 Peak month: 12
 Peak hour: 12

BASIC DATA, DIESEL:
 diesel ratings: 100.0 KW
 fuel use idling:
 (heat value) 40.0 KW
 fuel proportionality
 from 70.0 KW
 conversion efficiency:
 0.37
 diesel shut down crit.:
 wind power/load > 2.00
 wind power/rated > 0.80
 fuel cost:
 7.0 C/KWH(heat value)

extra o&m below 40 KW
 rising at zero load to
 70.0 C/HOUR

BASIC DATA, LOAD:
 distribution parameters:
 L0= 50.0 KW
 L1= 10.0 KW
 L2= 1.0
 L3= 1.0
 Peak month: 1

SIMULATION RESULTS:

hour	load kw	wind kw	fuel kw	cost c/kuh
1	48	0	143	20
2	49	0	145	20
3	50	0	147	20
4	51	0	149	20
5	46	0	138	20
6	48	0	142	20
7	51	2	144	19
8	46	10	117	17
9	49	0	144	20
10	46	0	139	20
11	49	1	142	20
12	51	53	40	6
13	53	60	40	6
14	49	80	40	7
15	52	95	40	6
16	53	70	40	6
17	48	60	40	7
18	50	54	40	6
19	52	41	62	9
20	52	35	75	10
21	46	15	105	16
22	49	15	111	16
23	50	6	133	18
24	45	0	137	21

24 HOURS SUMMARY:

acc. load: 1192 KWH
 av. windspeed 6.84 M/S
 wind power: 604 KWH
 diesel power: 704 KWH
 fuel used: 2461 KWH
 power dumped: 117 KWH
 diesel starts: 0
 diesel stopped 0 HOURS
 av. cost: 24.96 C/KWH

DISTRIBUTION CURVES:

load	diesel	wind	cost
0	0	29	62
10	0	8	0
20	0	0	8
30	0	12	16
40	54	41	8
50	45	8	4
60	0	0	0
70	0	0	0
80	0	0	0
90	0	0	0

(% of d or w rated power
 EXCEPT
 variable cost which is
 relative to 50 C/KWH)

REFERENCES

- Barker, P., Bowden, G., Outhred, H., Robins, B., and Williams, M., 1983 "Wind Energy Feasibility Study for Lord Howe Island", Energy Authority of NSW.
- Bonte, J. de., Clerks, W., Kraayvanger, A., Pierik, J., and Varmenhoven, A., 1985. "Two Dutch Autonomous Wind Diesel Systems", Wind Power '85 Conf., San Francisco (ECN Report 85-142).
- Chappel, M. and Templin, R., 1985. "And the Cold winds shall blow...", 7th Annual Conf. of BWEA, Oxford 1985, Mech. Eng. Press (to be publ.)
- Crawford, T., 1984. "Experience with 3 wind energy converters operating in parallel with diesel generators at Rottneest Island", Inst. Eng. Aus. Electric Energy Conf., Perth 1984.
- Crawford, T., 1985. "Wind-diesel systems, with particular reference to larger installations", NERDDC Wind Energy Workshop, UNSW 1985.
- Elder J., Boys, J., and Woodward, J., 1985. IEE Proc. Vol. 132, pp. 57-66
- Garside, J., 1982. "The Tristan de Cunna project" BWEA Conference, London.
- Infield, D., Slack, G., Lipman, N., and Musgrove, P. 1983 . IEE Proc. Vol. 130, pp. 613-619.
- Infield, D. and Puddy, J., 1984. In "Energy for Rural and Island Communities III" (Twidell, Riddock and Grainger, eds.), pp. 137-144, Pergamon Press, Oxford.
- Infield, D., Forbes, R., Goodyear P., Lipman, N., Magraw, J. Reynolds, R., Bleijs, J., Freris, L., Jenkins, N., and Attwood, R., 1985. "Further Progress with Wind/diesel Integration", 7th Annual Conf. of BWEA, Oxford 1985 (Mechanical Eng. Press (to be published) 1982. Int. Power Gen., Vol. 5, pp. 18-22).
- Jensen, J. and Sorensen, B., 1984 "Fundamentals of Energy Storage", Wiley, New York.
- Johnston G., 1985 "Wind Energy Systems", Prentice Hall, Englewood, Cliffs, p. 271.
- Lawson-Tancred, H., 1982. Int. Power Gen., Vol. 5, pp. 18-22.
- Langworthy, A., 1985. "Requirements and Options for Remote Area Power Supply System in NSW", Energy Authority of New South Wales, Report EA 85/17
- Lipman, H., 1984 "Wind Engineering Vol. 8, pp. 9-18.
- Lipman, H., 1985 "Wind Integration R & D" EWEA Workshop on Wind energy applications, Delphi 1985 (Rutherford Lab. Preprint ERG-85-002).
- Lundsager, P., and Madsen, H., 1985 "Modelling and Dynamic Analysis of the Riso Wind/Diesel System" Proc. 7th BWEA Conference, Mech. Eng. Press (to be publ.).

Madsen, H. and Lundsager, P., 1985 "The Wind Diesel Development programme at Riso Nat. Lab - status 1985", Riso National Lab. Report M-2537

Outhred, H., 1985 "Remote Area Power Supply: General Design Issues for Systems with Battery Storage (unpublished report).

Outhred, H., and Harrington, M., 1985 "A Study of the economic value of a wind generator for Lord Howe Island", Ann. Conf. of Int. Solar Energy Soc. (ANZ Sect.), UNSW.

Schott, F and Reiniger, J., 1984. In "Energy for Rural and Island Communities III (Twidell, Riddock and Grainger, eds). pp. 53-61, Pergammon Press, Oxford.

Sinclair, B., Stevenson, W., and Somerville, W., 1984. In "Energy for Rural and Island Communities III (Twidell, Riddock and Grainger, eds.), pp. 155-162, Pergammon Press, Oxford.

Somerville, W and Stevenson, W., 1985, MPS Review, June, 19-23

Sorensen, B., 1986 "The Status of Wind Generators in Europe", Energy Authority of New South Wales.

Stiller, P., Scott G., and Shaltens, R., 1983. IEEE Trans Vol. PAS-102, pp. 1788-1792.

Templin, R., and Rangi, R., 1983 IEE Proc. Vol. 130, pp. 555-561

Tsitsovits, A., and Freris, L, 1983 IEE Proc. vol. 130, pp. 587-595.

Tsitsovits, A., and Freris, L, 1985 IEE Proc. vol. 132, pp. 269-276.

Watt, M. and Harrington L., 1985 "Consideration of Environmental Factors associated with the installation of a wind generator for supplementary power supply to the Malabar Sewerage Works. Energy Authority of NSW, Sydney, Report No. EA 85/55.

Woychik, E., 1984 Sun World, Vol. 89, pp. 98-100

- 1/78 "TANKER OM EN PRAKSIS" - et matematikprojekt. Projekt rapport af: Anne Jensen, Lena Lindenskov, Marianne Kesselhahn og Nicolai Lomholt. Vejleder: Anders Madsen
- 2/78 "OPTIMERING" - Menneskets forøgede beherskelsesmuligheder af natur og samfund. Projekt rapport af: Tom J. Andersen, Tommy R. Andersen, Gert Kreinøe og Peter H. Lassen. Vejleder: Bernhelm Boss.
- 3/78 "OPGAVESAMLING", breddekursus i fysik. Af: Lasse Rasmussen, Aage Bonde Kræmmer og Jens Højgaard Jensen.
- 4/78 "TRE ESSAYS" - om matematikundervisning, matematiklæreruddannelsen og videnskabsrindalismen. Af: Mogens Niss. Nr. 4 er p.t. udgået.
- 5/78 "BIBLIOGRAFISK VEJLEDNING til studiet af DEN MODERNE FYSIKS HISTORIE". Af: Helge Kragh. Nr. 5 er p.t. udgået.
- 6/78 "NOGLE ARTIKLER OG DEBATINDLÆG OM - læreruddannelse og undervisning i fysik, og - de naturvidenskabelige fags situation efter studenteroprøret". Af: Karin Beyer, Jens Højgaard Jensen og Bent C. Jørgensen.
- 7/78 "MATEMATIKKENS FORHOLD TIL SAMFUNDSØKONOMIEN". Af: B.V. Gnedenko. Nr. 7 er udgået.
- 8/78 "DYNAMIK OG DIAGRAMMER". Introduktion til energy-bond-graph formalismen. Af: Peder Voetmann Christiansen.
- 9/78 "OM PRAKSIS' INDFLYDELSE PÅ MATEMATIKKENS UDVIKLING". - Motiver til Kepler's: "Nova Stereometria Dolliorum Vinariorum". Projekt rapport af: Lasse Rasmussen. Vejleder: Anders Madsen.
-
- 10/79 "THERMODYNAMIK I GYMNASIET". Projekt rapport af: Jan Christensen og Jeanne Mortensen. Vejledere: Karin Beyer og Peder Voetmann Christiansen.
- 11/79 "STATISTISKE MATERIALER". Af: Jørgen Larsen.
- 12/79 "LINEÆRE DIFFERENTIALLIGNINGER OG DIFFERENTIALLIGNINGSSYSTEMER". Af: Mogens Brun Heefelt. Nr. 12 er udgået.
- 13/79 "CAVENDISH'S FORSØG I GYMNASIET". Projekt rapport af: Gert Kreinøe. Vejleder: Albert Chr. Paulsen.
- 14/79 "BOOKS ABOUT MATHEMATICS: History, Philosophy, Education, Models, System Theory, and Works of". Af: Else Høyrup. Nr. 14 er p.t. udgået.
- 15/79 "STRUKTUREL STABILITET OG KATASTROFER i systemer i og udenfor termodynamisk ligevægt". Specialeopgave af: Leif S. Striegler. Vejleder: Peder Voetmann Christiansen.
- 16/79 "STATISTIK I KRÆFTFORSKNINGEN". Projekt rapport af: Michael Olsen og Jørn Jensen. Vejleder: Jørgen Larsen.
- 17/79 "AT SPØRGE OG AT SVARE i fysikundervisningen". Af: Albert Christian Paulsen.
- 18/79 "MATHEMATICS AND THE REAL WORLD", Proceedings af an International Workshop, Roskilde University Centre, Denmark, 1978. Preprint. Af: Bernhelm Booss og Mogens Niss (eds.)
- 19/79 "GEOMETRI, SKOLE OG VIRKELIGHED". Projekt rapport af: Tom J. Andersen, Tommy R. Andersen og Per H.H. Larsen. Vejleder: Mogens Niss.
- 20/79 "STATISTISKE MODELLER TIL BESTEMMELSE AF SIKRE DOSER FOR CARCINOGENE STOFFER". Projekt rapport af: Michael Olsen og Jørn Jensen. Vejleder: Jørgen Larsen
- 21/79 "KONTROL I GYMNASIET-FORMÅL OG KONSEKVENSER". Projekt rapport af: Crilles Bacher, Per S.Jensen, Preben Jensen og Torben Nysteen.
- 22/79 "SEMIOTIK OG SYSTEMEGENSKABER (I)". I-port lineært response og støj i fysikken. Af: Peder Voetmann Christiansen.
- 23/79 "ON THE HISTORY OF EARLY WAVE MECHANICS - with special emphasis on the role of reality". Af: Helge Kragh.
-
- 24/80 "MATEMATIKOPFATTELSE HOS 2.G'ERE". a+b 1. En analyse. 2. Interviewmateriale. Projekt rapport af: Jan Christensen og Knud Lindhardt Rasmussen. Vejleder: Mogens Niss.
- 25/80 "EKSAMENSOPGAVER", Dybdemodulet/fysik 1974-79.
- 26/80 "OM MATEMATISKE MODELLER". En projekt rapport og to artikler. Af: Jens Højgaard Jensen m.fl.
- 27/80 "METHODOLOGY AND PHILOSOPHY OF SCIENCE IN PAUL DIRAC'S PHYSICS". Af: Helge Kragh.
- 28/80 "DILEMATERISK RELAXATION - et forslag til en ny model bygget på væskernes viscoelastiske egenskaber". Projekt rapport af: Gert Kreinøe. Vejleder: Niels Boye Olsen.
- 29/80 "ODIN - undervisningsmateriale til et kursus i differentiaalligningsmodeller". Projekt rapport af: Tommy R. Andersen, Per H.H. Larsen og Peter H. Lassen. Vejleder: Mogens Brun Heefelt.
- 30/80 "FUSIONSENERGIEN - - - ATOMSAMFUNDETS ENDESTATION". Af: Oluf Danielsen. Nr. 30 er udgået.
- 31/80 "VIDENSKABSTEORETISKE PROBLEMER VED UNDERVISNINGSSYSTEMER BASERET PÅ MÆNGDELÆRE". Projekt rapport af: Troels Lange og Jørgen Karrebæk. Vejleder: Stig Andur Pedersen. Nr. 31 er p.t. udgået.
- 32/80 "POLYMERE STOFFERS VISCOELASTISKE EGENSKABER - BELYST VED HJÆLP AF MEKANISKE IMPEDANSMÅLINGER - GER MOSSBAUEREFFEKTIVITÄT". Projekt rapport af: Crilles Bacher og Preben Jensen. Vejledere: Niels Boye Olsen og Peder Voetmann Christiansen.
- 33/80 "KONSTITUERING AF FAG INDEN FOR TEKNISK - NATURVIDENSKABELIGE UDDANNELSER. I-II". Af: Arne Jakobsen.
- 34/80 "ENVIRONMENTAL IMPACT OF WIND ENERGY UTILIZATION". ENERGY SERIES NO. I. Af: Bent Sørensen. Nr. 34 er udgået.

- 35/80 "HISTORISKE STUDIER I DEN NYERE ATOMFYSIKS UDVIKLING".
Af: Helge Kragh.
- 36/80 "HVAD ER MENINGEN MED MATEMATIKUNDERVISNINGEN?".
Fire artikler.
Af: Mogens Niss.
- 37/80 "RENEWABLE ENERGY AND ENERGY STORAGE".
ENERGY SERIES NO. 2.
Af: Bent Sørensen.
-
- 38/81 "TIL EN HISTORIE TEORI OM NATURERKENDELSE, TEKNOLOGI OG SAMFUND".
Projekt rapport af: Erik Gade, Hans Hedal, Henrik Lau og Finn Physant.
Vejledere: Stig Andur Pedersen, Helge Kragh og Ib Thiersen.
Nr. 38 er p.t. udgået.
- 39/81 "TIL KRITIKKEN AF VEKSTØKONOMIEN".
Af: Jens Højgaard Jensen.
- 40/81 "TELEKOMMUNIKATION I DANMARK - oplæg til en teknologivurdering".
Projekt rapport af: Arne Jørgensen, Bruno Petersen og Jan Vedde.
Vejleder: Per Nørgaard.
- 41/81 "PLANNING AND POLICY CONSIDERATIONS RELATED TO THE INTRODUCTION OF RENEWABLE ENERGY SOURCES INTO ENERGY SUPPLY SYSTEMS".
ENERGY SERIES NO. 3.
Af: Bent Sørensen.
- 42/81 "VIDENSKAB TEORI SAMFUND - En introduktion til materialistiske videnskabsopfattelser".
Af: Helge Kragh og Stig Andur Pedersen.
- 43/81 1. "COMPARATIVE RISK ASSESSMENT OF TOTAL ENERGY SYSTEMS".
2. "ADVANTAGES AND DISADVANTAGES OF DECENTRALIZATION".
ENERGY SERIES NO. 4.
Af: Bent Sørensen.
- 44/81 "HISTORISKE UNDERSØGELSER AF DE EKSPERIMENTELLE FORUDSÆTNINGER FOR RUTHERFORDS ATOMMODEL".
Projekt rapport af: Niels Thor Nielsen.
Vejleder: Bent C. Jørgensen.
-
- 45/82 Er aldrig udkommet.
- 46/82 "EKSEMPLARISK UNDERVISNING OG FYSISK ERKENDELSE-1+11 ILLUSTRERET VED TO EKSEMPLER".
Projekt rapport af: Torben O. Olsen, Lasse Rasmussen og Niels Dreyer Sørensen.
Vejleder: Bent C. Jørgensen.
- 47/82 "BARSEBÄCK OG DET VÆRST OFFICIELT-TÆNKELIGE UHELD".
ENERGY SERIES NO. 5.
Af: Bent Sørensen.
- 48/82 "EN UNDERSØGELSE AF MATEMATIKUNDERVISNINGEN PÅ ADGANGSKURSUS TIL KØBENHAVNS TEKNIKUM".
Projekt rapport af: Lis Eilertzen, Jørgen Karrebæk, Troels Lange, Preben Nørregaard, Lissi Pedesen, Laust Rishøj, Lill Røn og Isac Showiki.
Vejleder: Mogens Niss.
- 49/82 "ANALYSE AF MULTISPEKTRALE SATELLITBILLEDER".
Projekt rapport af: Preben Nørregaard.
Vejledere: Jørgen Larsen og Rasmus Ole Rasmussen.
- 50/82 "HERSLEV - MULIGHEDER FOR VEDVARENDE ENERGI I EN LANDSBY".
ENERGY SERIES NO. 6.
Rapport af: Bent Christensen, Bent Hove Jensen, Dennis B. Møller, Bjarne Laursen, Bjarne Lillethorup og Jacob Mørch Pedersen.
Vejleder: Bent Sørensen.
- 51/82 "HVAD KAN DER GØRES FOR AT AFHJÆLPE PIGERS BLOKERING OVERFOR MATEMATIK?".
Projekt rapport af: Lis Eilertzen, Lissi Pedersen, Lill Røn og Susanne Stender.
- 52/82 "DESUSPENSION OF SPLITTING ELLIPTIC SYMBOLS".
Af: Bernhelm Booss og Krzysztof Wojciechowski.
- 53/82 "THE CONSTITUTION OF SUBJECTS IN ENGINEERING EDUCATION".
Af: Arne Jacobsen og Stig Andur Pedersen.
- 54/82 "FUTURES RESEARCH" - A Philosophical Analysis of Its Subject-Matter and Methods.
Af: Stig Andur Pedersen og Johannes Witt-Hansen.
- 55/82 "MATEMATISKE MODELLER" - Litteratur på Roskilde Universitetsbibliotek.
En biografi.
Af: Else Højrup.

Vedr. tekst nr. 55/82 se også tekst nr. 62/83.
- 56/82 "EN - TO - MANGE" -
En undersøgelse af matematisk økologi.
Projekt rapport af: Troels Lange.
Vejleder: Anders Madsen.
-
- 57/83 "ASPECT EKSPERIMENTET"-
Skjulte variable i kvantemekanikken?
Projekt rapport af: Tom Juul Andersen.
Vejleder: Peder Voetmann Christiansen.
Nr. 57 er udgået.
- 58/83 "MATEMATISKE VANDRINGER" - Modelbetragtninger over spredning af dyr mellem småbiotoper i agerlandet.
Projekt rapport af: Per Hammershøj Jensen og Lene Vagn Rasmussen.
Vejleder: Jørgen Larsen.
- 59/83 "THE METHODOLOGY OF ENERGY PLANNING".
ENERGY SERIES NO. 7.
Af: Bent Sørensen.
- 60/83 "MATEMATISK MODEKSPERTISE"- et eksempel.
Projekt rapport af: Erik O. Gade, Jørgen Karrebæk og Preben Nørregaard.
Vejleder: Anders Madsen.
- 61/83 "FYSIKS IDEOLOGISKE FUNKTION, SOM ET EKSEMPEL PÅ EN NATURVIDENSKAB - HISTORISK SET".
Projekt rapport af: Annette Post Nielsen.
Vejledere: Jens Højrup, Jens Højgaard Jensen og Jørgen Vogelius.
- 62/83 "MATEMATISKE MODELLER" - Litteratur på Roskilde Universitetsbibliotek.
En biografi 2. rev. udgave.
Af: Else Højrup.
- 63/83 "CREATING ENERGY FUTURES: A SHORT GUIDE TO ENERGY PLANNING".
ENERGY SERIES NO. 8.
Af: David Crossley og Bent Sørensen.
- 64/83 "VON MATEMATIK UND KRIEG".
Af: Bernhelm Booss og Jens Højrup.
- 65/83 "ANVENDT MATEMATIK - TEORI ELLER PRAKSIS".
Projekt rapport af: Per Hedegård Andersen, Kirsten Habekost, Carsten Holst-Jensen, Annelise von Moos, Else Marie Pedersen og Erling Møller Pedersen.
Vejledere: Bernhelm Booss og Klaus Grünbaum.
- 66/83 "MATEMATISKE MODELLER FOR PERIODISK SELEKTION I ESCHERICHIA COLI".
Projekt rapport af: Hanne Lisbet Andersen, Ole Richard Jensen og Klavs Frisø Dahl.
Vejledere: Jørgen Larsen og Anders Hede Madsen.
- 67/83 "ELEPSOIDE METODEN - EN NY METODE TIL LINEÆR PROGRAMMERING?".
Projekt rapport af: Lone Billmann og Lars Boye.
Vejleder: Mogens Brun Heefelt.
- 68/83 "STOKASTISKE MODELLER I POPULATIONSGENETIK" - til kritikken af teoriladede modeller.
Projekt rapport af: Lise Odgård Gade, Susanne Hansen, Michael Hviid og Frank Mølgård Olsen.
Vejleder: Jørgen Larsen.

- 69/83 "ELEVFORUDSETNINGER I FYSIK"
- en test i l.g med kommentarer.
Af: Albert C. Paulsen.
- 70/83 "INDLÆRINGS- OG FORMIDLINGSPROBLEMER I MATEMATIK PÅ VOKSENUNDERVISNINGSNIVEAU".
Projektrapport af: Hanne Lisbet Andersen, Torben J. Andreasen, Svend Åge Houmann, Helle Glerup Jensen, Keld Fl. Nielsen, Lene Vagn Rasmussen.
Vejleder: Klaus Grünbaum og Anders Hede Madsen.
- 71/83 "PIGER OG FYSIK"
- et problem og en udfordring for skolen?
Af: Karin Beyer, Sussanne Blegaa, Birthe Olsen, Jette Reich og Mette Vedelsby.
- 72/83 "VERDEN IFØLGE PEIRCE" - to metafysiske essays, om og af C.S Peirce.
Af: Peder Voetmann Christiansen.
- 73/83 ""EN ENERGIANALYSE AF LANDBRUG"
- økologisk contra traditionelt.
ENERGY SERIES NO. 9
Specialeopgave i fysik af: Bent Hove Jensen.
Vejleder: Bent Sørensen.
-
- 74/84 "MINIATURISERING AF MIKROELEKTRONIK" - om videnskabeliggjort teknologi og nytten af at lære fysik.
Projektrapport af: Bodil Harder og Linda Szkotak Jensen.
Vejledere: Jens Højgaard Jensen og Bent C. Jørgensen.
- 75/84 "MATEMATIKUNDERVISNINGEN I FREMTIDENS GYMNASIUM"
- Case: Linear programmering.
Projektrapport af: Morten Blomhøj, Klavs Frisdahl og Frank Mølgaard Olsen.
Vejledere: Mogens Brun Heefelt og Jens Bjørneboe.
- 76/84 "KERNEKRAFT I DANMARK?" - Et høringsvar indkaldt af miljøministeriet, med kritik af miljøstyrelsens rapporter af 15. marts 1984.
ENERGY SERIES No. 10
Af: Niels Boye Olsen og Bent Sørensen.
- 77/84 "POLITISKE INDEKS - FUP ELLER FAKTA?"
Opinionsundersøgelser belyst ved statistiske modeller.
Projektrapport af: Svend Åge Houmann, Keld Nielsen og Susanne Stender.
Vejledere: Jørgen Larsen og Jens Bjørneboe.
- 78/84 "JÆVSTRØMSLEDNINGSEVNE OG GITTERSTRUKTUR I AMORFT GERMANIUM".
Specialrapport af: Hans Hedal, Frank C. Ludvigsen og Finn C. Physant.
Vejleder: Niels Boye Olsen.
- 79/84 "MATEMATIK OG ALMENDANNELSE".
Projektrapport af: Henrik Coster, Mikael Wennerberg Johansen, Povl Kattler, Birgitte Lydholm og Morten Overgaard Nielsen.
Vejleder: Bernhelm Booss.
- 80/84 "KURSUSMATERIALE TIL MATEMATIK B".
Af: Mogens Brun Heefelt.
- 81/84 "FREKVENSAFHÆNGIG LEDNINGSEVNE I AMORFT GERMANIUM".
Specialrapport af: Jørgen Wind Petersen og Jan Christensen.
Vejleder: Niels Boye Olsen.
- 82/84 "MATEMATIK - OG FYSIKUNDERVISNINGEN I DET AUTOMATISEREDE SAMFUND".
Rapport fra et seminar afholdt i Hvidovre 25-27 april 1983.
Red.: Jens Højgaard Jensen, Bent C. Jørgensen og Mogens Niss.
- 83/84 "ON THE QUANTIFICATION OF SECURITY":
PEACE RESEARCH SERIES NO. 1
Af: Bent Sørensen
nr. 83 er p.t. udgået
- 84/84 "NOGLE ARTIKLER OM MATEMATIK, FYSIK OG ALMENDANNELSE".
Af: Jens Højgaard Jensen, Mogens Niss m. fl.
- 85/84 "CENTRIFUGALREGULATORER OG MATEMATIK".
Specialrapport af: Per Hedegård Andersen, Carsten Holst-Jensen, Else Marie Pedersen og Erling Møller Pedersen.
Vejleder: Stig Andur Pedersen.
- 86/84 "SECURITY IMPLICATIONS OF ALTERNATIVE DEFENSE OPTIONS FOR WESTERN EUROPE".
PEACE RESEARCH SERIES NO. 2
Af: Bent Sørensen.
- 87/84 "A SIMPLE MODEL OF AC HOPPING CONDUCTIVITY IN DISORDERED SOLIDS".
Af: Jeppe C. Dyre.
- 88/84 "RISE, FALL AND RESURRECTION OF INFINITESIMALS".
Af: Detlef Laugwitz.
- 89/84 "FJERNVARMEOPTIMERING".
Af: Bjarne Lillethorup og Jacob Mørch Pedersen.
- 90/84 "ENERGI I L.G - EN TEORI FOR TILRETTELÆGGELSE".
Af: Albert Chr. Paulsen.
-
- 91/85 "KVANTETEORI FOR GYMNASIET".
1. Lærervejledning
Projektrapport af: Biger Lundgren, Henning Sten Hansen og John Johansson.
Vejleder: Torsten Meyer.
- 92/85 "KVANTETEORI FOR GYMNASIET".
2. Materiale
Projektrapport af: Biger Lundgren, Henning Sten Hansen og John Johansson.
Vejleder: Torsten Meyer.
- 93/85 "THE SEMIOTICS OF QUANTUM - NON - LOCALITY".
Af: Peder Voetmann Christiansen.
- 94/85 "TREENIGHEDEN BOURBAKI - generalen, matematikeren og ånden".
Projektrapport af: Morten Blomhøj, Klavs Frisdahl og Frank M. Olsen.
Vejleder: Mogens Niss.
- 95/85 "AN ALTERNATIV DEFENSE PLAN FOR WESTERN EUROPE".
PEACE RESEARCH SERIES NO. 3
Af: Bent Sørensen
- 96/85 "ASPEKTER VED KRAFTVARMEFORSYNING".
Af: Bjarne Lillethorup.
Vejleder: Bent Sørensen.
- 97/85 "ON THE PHYSICS OF A.C. HOPPING CONDUCTIVITY".
Af: Jeppe C. Dyre.
- 98/85 "VALGMULIGHEDER I INFORMATIONSDALDEREN".
Af: Bent Sørensen.
- 99/85 "Der er langt fra Q til R".
Projektrapport af: Niels Jørgensen og Mikael Klintorp.
Vejleder: Stig Andur Pedersen.
- 100/85 "TALSYSTEMETS OPBYGNING".
Af: Mogens Niss.
- 101/85 "EXTENDED MOMENTUM THEORY FOR WINDMILLS IN PERTURBATIVE FORM".
Af: Ganesh Sengupta.
- 102/85 OPSTILLING OG ANALYSE AF MATEMATISKE MODELLER, BELYST VED MODELLER OVER KØRS FODEROPTAGELSE OG - OMSÆTNING".
Projektrapport af: Lis Eilertzen, Kirsten Habekost, Lill Røn og Susanne Stender.
Vejleder: Klaus Grünbaum.

- 103/85 "ØDSLE KOLDKRIGERE OG VIDENSKABENS LYSE IDEER".
 Projekt rapport af: Niels Ole Dam og Kurt Jensen.
 Vejleder: Bent Sørensen.
- 104/85 "ANALOGREGNEMASKINEN OG LORENZLIGNINGER".
 Af: Jens Jøger.
- 105/85 "THE FREQUENCY DEPENDENCE OF THE SPECIFIC HEAT OF THE GLASS REANSTITION".
 Af: Tage Christensen.
- "A SIMPLE MODEL AF AC HOPPING CONDUCTIVITY".
 Af: Jeppe C. Dyre.
 Contributions to the Third International Conference on the Structure of Non - Crystalline Materials held in Grenoble July 1985.
- 106/85 "QUANTUM THEORY OF EXTENDED PARTICLES".
 Af: Bent Sørensen.
- 107/85 "EN MYG GØR INGEN EPIDEMI".
 - flodblindhed som eksempel på matematisk modellering af et epidemiologisk problem.
 Projekt rapport af: Per Hedegård Andersen, Lars Boye, Carsten Holst Jensen, Else Marie Pedersen og Erling Møller Pedersen.
 Vejleder: Jesper Larsen.
- 108/85 "APPLICATIONS AND MODELLING IN THE MATHEMATICS CURRICULUM" - state and trends -
 Af: Mogens Niss.
- 109/85 "COX I STUDIETIDEN" - Cox's regressionsmodel anvendt på studenteroplysninger fra RUC.
 Projekt rapport af: Mikael Wennerberg Johansen, Poul Katler og Torben J. Andreassen.
 Vejleder: Jørgen Larsen.
- 110/85 "PLANNING FOR SECURITY".
 Af: Bent Sørensen
- 111/85 "JORDEN RUNDT PÅ FLADE KORT".
 Projekt rapport af: Birgit Andresen, Beatriz Quinones og Jimmy Staal.
 Vejleder: Mogens Niss.
- 112/85 "VIDENSKABELIGGØRELSE AF DANSK TEKNOLOGISK INNOVATION FREM TIL 1950 - BELYST VED EKSEMPLER".
 Projekt rapport af: Erik Odgaard Gade, Hans Hedal, Frank C. Ludvigsen, Annette Post Nielsen og Finn Physant.
 Vejleder: Claus Bryld og Bent C. Jørgensen.
- 113/85 "DESUSPENSION OF SPLITTING ELLIPTIC SYMBOLS 11".
 Af: Bernhelm Booss og Krzysztof Wojciechowski.
- 114/85 "ANVENDELSE AF GRAFISKE METODER TIL ANALYSE AF KONTIGENTABELLER".
 Projekt rapport af: Lone Billmann, Ole R. Jensen og Arne-Lise von Moos.
 Vejleder: Jørgen Larsen.
- 115/85 "MATEMATIKKENS UDVIKLING OP TIL RENÆSSANCEN".
 Af: Mogens Niss.
- 116/85 "A PHENOMENOLOGICAL MODEL FOR THE MEYER-NELDEL RULE".
 Af: Jeppe C. Dyre.
- 117/85 "KRAFT & FJERNVARMEOPTIMERING"
 Af: Jacob Mørch Pedersen.
 Vejleder: Bent Sørensen
- 118/85 "TILFÆLDIGHEDEN OG NØDVENDIGHEDEN IFØLGE PEIRCE OG FYSIKKEN".
 Af: Peder Voetmann Christiansen
- 120/86 "ET ANIAT STATISTISKE STANDARDMODELLER".
 Af: Jørgen Larsen
- 121/86 "SIMULATION I KONTINUERT TID".
 Af: Peder Voetmann Christiansen.
- 122/86 "ON THE MECHANISM OF GLASS IONIC CONDUCTIVITY".
 Af: Jeppe C. Dyre.
- 123/86 "GYMNASIEFYSIKKEN OG DEN STORE VERDEN".
 Fysiklærerforeningen, IMFUFA, RUC.
- 124/86 "ORGAVESAMLING I MATEMATIK".
 Samtlige opgaver stillet i tiden 1974-jan. 1986.
- 125/86 "UVBY, 6 - systemet - en effektiv fotometrisk spektral-klassifikation af B-, A- og F-stjerner".
 Projekt rapport af: Birger Lundgren.
- 126/86 "OM UDVIKLINGEN AF DEN SPECIELLE RELATIVITETSTEORI".
 Projekt rapport af: Lise Odgaard & Linda Szkotak Jensen
 Vejledere: Karin Beyer & Stig Andur Pedersen.
- 127/86 "GALOIS' BIDRAG TIL UDVIKLINGEN AF DEN ABSTRAKTE ALGEBRA".
 Projekt rapport af: Pernille Sand, Heine Larsen & Lars Frandsen.
 Vejleder: Mogens Niss.
- 128/86 "SMÅKRYB" - en ikke-standard analyse.
 Projekt rapport af: Niels Jørgensen & Mikael Klintorp.
 Vejleder: Jeppe Dyre.
- 129/86 "PHYSICS IN SOCIETY"
 Lecture Notes 1983 (1986)
 Af: Bent Sørensen
- 119/86 "DET ER GANSKE VIST - - EUKLIDS FEMTE POSTULAT KUNNE NOK SKABE RØRE I ANDEDAMMEN".
 Af: Iben Maj Christiansen
 Vejleder: Mogens Niss.